

SOLICITATION VERSION

**IN THE UNITED STATES BANKRUPTCY COURT
FOR THE SOUTHERN DISTRICT OF TEXAS
HOUSTON DIVISION**

<i>In re:</i>)	
)	Chapter 11
GWG Holdings, Inc., <i>et al.</i> , ¹)	Case No. 22-90032 (MI)
)	(Jointly Administered)
Debtors.)	

**DISCLOSURE STATEMENT FOR THE DEBTORS' FURTHER MODIFIED
SECOND AMENDED JOINT CHAPTER 11 PLAN,
SUBMITTED BY THE DEBTORS, THE BONDHOLDER COMMITTEE,
AND L BOND MANAGEMENT, LLC AS CO-PROponents**

¹ The Debtors in these Chapter 11 Cases, along with the last four digits of each Debtor's federal tax identification number, are: GWG Holdings, Inc. (2607); GWG Life, LLC (6955); GWG Life USA, LLC (5538); GWG DLP Funding IV, LLC (2589); GWG DLP Funding Holdings VI, LLC (6955); and GWG DLP Funding VI, LLC (6955). The location of Debtor GWG Holdings, Inc.'s principal place of business and the Debtors' service address is 325 N. St. Paul Street, Suite 2650 Dallas, TX 75201. Further information regarding the Debtors and these Chapter 11 Cases is available at the website of the Debtors' claims and noticing agent: <https://donlinrecano.com/gwg>.

JACKSON WALKER LLP

Matthew D. Cavanaugh (TX Bar No. 24062656)
Kristhy M. Peguero (TX Bar No. 24102776)
1401 McKinney Street, Suite 1900
Houston, Texas 77010
Telephone: (713) 752-4200
Email: kpeguero@jw.com
mcavanaugh@jw.com

*Co-Counsel for the Debtors
and Debtors in Possession*

MAYER BROWN LLP

Charles S. Kelley (TX Bar No. 11199580)
700 Louisiana Street, Suite 3400
Houston, Texas 77002-2730
Telephone: (713) 238-3000
Email: ckelley@mayerbrown.com

- and -

Thomas S. Kiriakos (admitted *pro hac vice*)
Louis S. Chiappetta (admitted *pro hac vice*)
Jamie R. Netznik (admitted *pro hac vice*)
Lisa Holl Chang
Joshua R. Gross (admitted *pro hac vice*)
Jade Edwards
71 S. Wacker Drive
Chicago, Illinois 60606
Telephone: (312) 782-0600
Email: tkiriakos@mayerbrown.com
lchiappetta@mayerbrown.com
jnetznik@mayerbrown.com
lhollchang@mayerbrown.com
jgross@mayerbrown.com
jmedwards@mayerbrown.com

- and -

Adam C. Paul (admitted *pro hac vice*)
Lucy F. Kweskin (admitted *pro hac vice*)
Ashley Anglade
1221 Avenue of the Americas
New York, New York 10020-1001
Telephone: (212) 506-2500
Email: apaul@mayerbrown.com
lkweskin@mayerbrown.com
aanglade@mayerbrown.com

*Counsel for the Debtors
and Debtors in Possession*

Dated: April 20, 2023

IMPORTANT INFORMATION ABOUT THIS DISCLOSURE STATEMENT

**THE DEADLINE TO VOTE ON THE SECOND AMENDED PLAN IS
May 31, 2023 at 4:00 p.m. (prevailing Central Time)**

**THE DEADLINE TO OBJECT TO THE SECOND AMENDED PLAN IS
May 31, 2023 at 11:59 p.m. (prevailing Central Time)**

FOR YOUR VOTE TO BE COUNTED, YOUR BALLOT MUST BE ACTUALLY RECEIVED BY DONLIN, RECANO & COMPANY, INC. ON OR BEFORE THE VOTING DEADLINE AS DESCRIBED HEREIN.

THE DEBTORS ARE PROVIDING THE INFORMATION IN THIS DISCLOSURE STATEMENT TO HOLDERS OF CLAIMS AND INTERESTS FOR PURPOSES OF SOLICITING VOTES TO ACCEPT OR REJECT THE *DEBTORS' SECOND AMENDED JOINT CHAPTER 11 PLAN*. NOTHING IN THIS DISCLOSURE STATEMENT MAY BE RELIED UPON OR USED BY ANY INDIVIDUAL OR ENTITY FOR ANY OTHER PURPOSE AND SHALL NOT BE BINDING ON ANY INDIVIDUAL OR ENTITY. BEFORE DECIDING WHETHER TO VOTE FOR OR AGAINST THE SECOND AMENDED PLAN, EACH HOLDER ENTITLED TO VOTE SHOULD CAREFULLY CONSIDER ALL OF THE INFORMATION IN THIS DISCLOSURE STATEMENT, INCLUDING THE RISK FACTORS DESCRIBED IN ARTICLE VIII HEREIN. IN THE EVENT OF ANY INCONSISTENCY BETWEEN THE DISCLOSURE STATEMENT AND THE SECOND AMENDED PLAN, THE RELEVANT PROVISIONS OF THE SECOND AMENDED PLAN WILL GOVERN.

THE DEBTORS URGE ALL HOLDERS OF CLAIMS AND INTERESTS WHOSE VOTES ARE BEING SOLICITED TO VOTE TO ACCEPT THE SECOND AMENDED PLAN. THE DEBTORS URGE EACH HOLDER OF A CLAIM OR INTEREST TO CONSULT WITH ITS OWN ADVISORS WITH RESPECT TO ANY LEGAL, FINANCIAL, SECURITIES, TAX, OR BUSINESS ADVICE IN REVIEWING THIS DISCLOSURE STATEMENT, THE SECOND AMENDED PLAN, AND THE PROPOSED TRANSACTIONS CONTEMPLATED THEREBY. FURTHERMORE, THE BANKRUPTCY COURT'S APPROVAL OF THE ADEQUACY OF THE INFORMATION CONTAINED IN THIS DISCLOSURE STATEMENT DOES NOT CONSTITUTE THE BANKRUPTCY COURT'S APPROVAL OF THE SECOND AMENDED PLAN.

THE SECOND AMENDED PLAN WAS APPROVED BY THE DEBTORS' MANAGEMENT AND GOVERNING BOARDS, INCLUDING THE CHIEF RESTRUCTURING OFFICER AND THE SPECIAL COMMITTEE OF THE BOARD OF DIRECTORS OF GWG HOLDINGS, INC. THAT WAS FORMED IN CONNECTION WITH THE CHAPTER 11 CASES TO, AMONG OTHER THINGS, ANALYZE AND EVALUATE A CHAPTER 11 PLAN.

THE SECOND AMENDED PLAN IS SUPPORTED BY THE OFFICIAL COMMITTEE OF BONDHOLDERS THAT WAS APPOINTED BY THE U.S. TRUSTEE

TO REPRESENT THE INTERESTS OF BONDHOLDERS IN THESE CHAPTER 11 CASES. THE BONDHOLDER COMMITTEE HAS AGREED TO BE A PROPONENT OF THE SECOND AMENDED PLAN, SUPPORTS THE SECOND AMENDED PLAN, AND RECOMMENDS THAT BONDHOLDERS VOTE TO ACCEPT THE SECOND AMENDED PLAN. NOTWITHSTANDING THE FOREGOING, THE DISCLOSURE STATEMENT HAS BEEN PREPARED BY THE DEBTORS (SUBJECT TO THE DISCLAIMERS AND OTHER QUALIFICATIONS SET FORTH HEREIN), AND THE BONDHOLDER COMMITTEE DOES NOT ADOPT ALL OF THE STATEMENTS CONTAINED HEREIN INCLUDING, BUT NOT LIMITED TO, ANY STATEMENTS REGARDING BENEFICIENT AND ITS AFFILIATES AND RELATED ENTITIES, THE PURPORTED VALUE OF BENEFICIENT AND THE DEBTORS' INTERESTS IN BENEFICIENT, OR ANY STATEMENTS REGARDING ANY OF THE DEBTORS' PREPETITION TRANSACTIONS. FOR A DISCUSSION OF THE BONDHOLDER COMMITTEE'S VIEWS ON CERTAIN OF THESE MATTERS, THE BONDHOLDER COMMITTEE REFERS TO THE STANDING MOTION AND THE PROPOSED COMPLAINT ATTACHED THERETO.

L BOND MANAGEMENT, LLC, WHICH REPRESENTS THE INTERESTS OF CERTAIN BONDHOLDERS THAT HOLD SELLER TRUST L BONDS (AS DESCRIBED FURTHER HEREIN), HAS ALSO APPROVED THE SECOND AMENDED PLAN, HAS AGREED TO BE A PROPONENT OF THE SECOND AMENDED PLAN, SUPPORTS THE SECOND AMENDED PLAN, AND URGES ALL BONDHOLDERS TO VOTE TO ACCEPT THE SECOND AMENDED PLAN.

THIS DISCLOSURE STATEMENT CONTAINS, AMONG OTHER THINGS, SUMMARIES OF THE SECOND AMENDED PLAN, CERTAIN STATUTORY PROVISIONS, CERTAIN EVENTS IN THE CHAPTER 11 CASES, AND CERTAIN DOCUMENTS AND/OR ARRANGEMENTS THAT WILL IMPLEMENT THE WIND DOWN TRANSACTIONS DESCRIBED HEREIN. ALTHOUGH THE DEBTORS BELIEVE THAT THESE SUMMARIES ARE FAIR AND ACCURATE, THESE SUMMARIES ARE QUALIFIED IN THEIR ENTIRETY TO THE EXTENT THAT THEY DO NOT SET FORTH THE ENTIRE TEXT OF SUCH DOCUMENTS OR STATUTORY PROVISIONS OR EVERY DETAIL OF SUCH ANTICIPATED EVENTS. IN THE EVENT OF ANY INCONSISTENCY OR DISCREPANCY BETWEEN A DESCRIPTION IN THIS DISCLOSURE STATEMENT AND THE TERMS AND PROVISIONS OF THE SECOND AMENDED PLAN OR ANY OTHER DOCUMENTS INCORPORATED HEREIN BY REFERENCE, THE SECOND AMENDED PLAN OR SUCH OTHER DOCUMENTS WILL GOVERN FOR ALL PURPOSES. FACTUAL INFORMATION CONTAINED IN THIS DISCLOSURE STATEMENT HAS BEEN PROVIDED BY THE DEBTORS' MANAGEMENT OR THIRD-PARTY ADVISORS EXCEPT WHERE OTHERWISE SPECIFICALLY NOTED. THE DEBTORS DO NOT REPRESENT OR WARRANT THAT THE INFORMATION CONTAINED HEREIN OR ATTACHED HERETO IS WITHOUT ANY MATERIAL INACCURACY OR OMISSION.

IN PREPARING THIS DISCLOSURE STATEMENT, THE DEBTORS RELIED ON FINANCIAL DATA DERIVED FROM THE DEBTORS' BOOKS AND RECORDS AND ON VARIOUS ASSUMPTIONS REGARDING THE DEBTORS' BUSINESSES.

ALTHOUGH THE DEBTORS BELIEVE THAT SUCH FINANCIAL INFORMATION FAIRLY REFLECTS THE FINANCIAL CONDITION OF THE DEBTORS AS OF THE DATE HEREOF AND THAT THE ASSUMPTIONS REGARDING FUTURE EVENTS REFLECT REASONABLE BUSINESS JUDGMENTS, NO REPRESENTATIONS OR WARRANTIES ARE MADE AS TO THE ACCURACY OF THE FINANCIAL INFORMATION CONTAINED HEREIN OR ASSUMPTIONS REGARDING THE DEBTORS' BUSINESSES AND ANY FUTURE RESULTS. THE DEBTORS EXPRESSLY CAUTION READERS NOT TO PLACE UNDUE RELIANCE ON ANY FORWARD-LOOKING STATEMENTS CONTAINED HEREIN.

THIS DISCLOSURE STATEMENT DOES NOT CONSTITUTE, AND MAY NOT BE CONSTRUED AS, AN ADMISSION OF FACT, LIABILITY, STIPULATION, OR WAIVER. THE DEBTORS OR ANY OTHER AUTHORIZED PARTY IN INTEREST MAY SEEK TO INVESTIGATE CLAIMS AND MAY OBJECT TO CLAIMS AFTER THE CONFIRMATION OR EFFECTIVE DATE OF THE SECOND AMENDED PLAN IRRESPECTIVE OF WHETHER THIS DISCLOSURE STATEMENT IDENTIFIES ANY SUCH CLAIMS OR OBJECTIONS TO CLAIMS.

THE DEBTORS ARE MAKING THE STATEMENTS AND PROVIDING THE FINANCIAL INFORMATION CONTAINED IN THIS DISCLOSURE STATEMENT AS OF THE DATE HEREOF, UNLESS OTHERWISE SPECIFICALLY NOTED. ALTHOUGH THE DEBTORS MAY SUBSEQUENTLY UPDATE THE INFORMATION IN THIS DISCLOSURE STATEMENT, THE DEBTORS HAVE NO AFFIRMATIVE DUTY TO DO SO AND EXPRESSLY DISCLAIM ANY DUTY TO PUBLICLY UPDATE ANY FORWARD-LOOKING STATEMENTS, WHETHER AS A RESULT OF NEW INFORMATION, FUTURE EVENTS, OR OTHERWISE. HOLDERS OF CLAIMS AND INTERESTS REVIEWING THIS DISCLOSURE STATEMENT SHOULD NOT INFER THAT, AT THE TIME OF THEIR REVIEW, THE FACTS SET FORTH HEREIN HAVE NOT CHANGED SINCE THIS DISCLOSURE STATEMENT WAS FILED. INFORMATION CONTAINED HEREIN IS SUBJECT TO COMPLETION, MODIFICATION, OR AMENDMENT. THE DEBTORS RESERVE THE RIGHT TO FILE AN AMENDED OR MODIFIED PLAN AND RELATED DISCLOSURE STATEMENT AT ANY TIME.

THE DEBTORS HAVE NOT AUTHORIZED ANY ENTITY TO GIVE ANY INFORMATION ABOUT OR CONCERNING THE SECOND AMENDED PLAN OTHER THAN WHAT IS CONTAINED IN THIS DISCLOSURE STATEMENT. THE DEBTORS HAVE NOT AUTHORIZED ANY REPRESENTATIONS CONCERNING THE DEBTORS OR THE VALUE OF THEIR PROPERTY OTHER THAN AS SET FORTH IN THIS DISCLOSURE STATEMENT.

IF THE SECOND AMENDED PLAN IS CONFIRMED BY THE BANKRUPTCY COURT AND THE EFFECTIVE DATE OF THE SECOND AMENDED PLAN OCCURS, ALL HOLDERS OF CLAIMS AND INTERESTS (INCLUDING THOSE HOLDERS WHO DO NOT SUBMIT BALLOTS TO ACCEPT OR REJECT THE SECOND AMENDED PLAN, WHO VOTE TO REJECT THE SECOND AMENDED PLAN, OR WHO ARE NOT

ENTITLED TO VOTE ON THE SECOND AMENDED PLAN) WILL BE BOUND BY THE TERMS OF THE SECOND AMENDED PLAN.

THE CONFIRMATION AND EFFECTIVENESS OF THE SECOND AMENDED PLAN ARE SUBJECT TO CERTAIN MATERIAL CONDITIONS PRECEDENT DESCRIBED HEREIN AND SET FORTH IN ARTICLE IX OF THE SECOND AMENDED PLAN. THERE IS NO ASSURANCE THAT THE SECOND AMENDED PLAN WILL BE CONFIRMED, OR IF CONFIRMED, THAT THE CONDITIONS REQUIRED TO BE SATISFIED FOR THE SECOND AMENDED PLAN TO GO EFFECTIVE WILL BE SATISFIED OR WAIVED.

YOU ARE ENCOURAGED TO READ THE SECOND AMENDED PLAN AND THIS DISCLOSURE STATEMENT IN ITS ENTIRETY, INCLUDING ARTICLE VIII, ENTITLED “RISK FACTORS,” BEFORE SUBMITTING YOUR BALLOT TO VOTE ON THE SECOND AMENDED PLAN.

THE BANKRUPTCY COURT’S APPROVAL OF THIS DISCLOSURE STATEMENT DOES NOT CONSTITUTE A GUARANTEE BY THE BANKRUPTCY COURT OF THE ACCURACY OR COMPLETENESS OF THE INFORMATION CONTAINED HEREIN OR AN ENDORSEMENT BY THE BANKRUPTCY COURT OF THE MERITS OF THE SECOND AMENDED PLAN.

THIS DISCLOSURE STATEMENT HAS BEEN PREPARED IN ACCORDANCE WITH SECTION 1125 OF THE BANKRUPTCY CODE AND BANKRUPTCY RULE 3016(B) AND IS NOT NECESSARILY PREPARED IN ACCORDANCE WITH FEDERAL OR STATE SECURITIES LAWS OR OTHER SIMILAR LAWS. THIS DISCLOSURE STATEMENT HAS NOT BEEN APPROVED OR DISAPPROVED BY THE UNITED STATES SECURITIES AND EXCHANGE COMMISSION (THE “SEC”) OR ANY SIMILAR FEDERAL, STATE, LOCAL, OR FOREIGN REGULATORY AGENCY, NOR HAS THE SEC OR ANY OTHER AGENCY PASSED UPON THE ACCURACY OR ADEQUACY OF THE STATEMENTS CONTAINED IN THIS DISCLOSURE STATEMENT. ANY REPRESENTATION TO THE CONTRARY IS UNLAWFUL.

THE DEBTORS HAVE SOUGHT TO ENSURE THE ACCURACY OF THE FINANCIAL INFORMATION PROVIDED IN THIS DISCLOSURE STATEMENT; HOWEVER, THE FINANCIAL INFORMATION CONTAINED IN THIS DISCLOSURE STATEMENT OR INCORPORATED HEREIN BY REFERENCE HAS NOT BEEN, AND WILL NOT BE, AUDITED OR REVIEWED BY THE DEBTORS’ INDEPENDENT AUDITORS UNLESS EXPLICITLY PROVIDED OTHERWISE.

**SPECIAL NOTICE REGARDING FEDERAL AND STATE SECURITIES LAWS
AND FORWARD-LOOKING STATEMENTS**

The Debtors intend that the New WDT Interests shall not be “securities” under applicable laws and believe the New WDT Interests should not be deemed to be “securities,” but to the extent such instruments are deemed to be “securities,” the Debtors believe the issuance of the New WDT Interests under the Second Amended Plan is exempt, pursuant to section 1145(a) of the Bankruptcy Code. This Disclosure Statement does not constitute an offer to sell or the solicitation of an offer to buy securities in any state or jurisdiction in which such offer or solicitation is not authorized.

The Debtors make statements in this Disclosure Statement that are considered forward-looking statements under federal securities laws. The Debtors consider all statements regarding anticipated or future matters to be forward-looking statements. Statements containing words such as “anticipate,” “believe,” “estimate,” “expect,” “intend,” “plan,” “project,” “target,” “model,” “can,” “could,” “may,” “should,” “will,” “would,” or similar words or the negative thereof, constitute “forward looking statements.” However, not all forward-looking statements in this disclosure statement may contain one or more of these identifying terms. Forward-looking statements are not guarantees of success of the Debtors’ or Wind Down Debtors’ ability to satisfy all Claims or Interests to be paid under the Second Amended Plan. There are risks, uncertainties, and other important factors that need to be considered. These risks, uncertainties, and factors may include the following: the Debtors’ or Wind Down Debtors’ ability to confirm and consummate the Second Amended Plan; the potential that the Debtors or Wind Down Debtors may need to pursue an alternative transaction if the Second Amended Plan is not confirmed; the potential adverse impact of the chapter 11 cases on the Debtors’ or Wind Down Debtors’ operations, management, and relationships with third parties; inherent uncertainty associated with estimating the future values of the Debtors’ assets and the risk that the Debtors or the Wind Down Debtors’ may not be able to monetize such assets in a timely fashion or on terms that are consistent with the value estimates presented herein; the risks associated with operating the Debtors’ businesses during the chapter 11 cases; stakeholders’ responses to the chapter 11 cases; the Debtors’ inability to settle claims during the Chapter 11 Cases; general economic, business, and market conditions; exposure to litigation; the ability to divest certain assets in an orderly manner; and adverse tax changes.

TABLE OF CONTENTS

	Page
I. INTRODUCTION	1
II. THE PLAN	2
A. Overview of the Second Amended Plan and Potential Sources of Value to Stakeholders	2
B. Mediation and Related Resolutions	19
C. Summary of the Second Amended Plan	27
D. Additional Plan Information and Plan Supplement	34
III. QUESTIONS AND ANSWERS REGARDING THIS DISCLOSURE STATEMENT AND THE SECOND AMENDED PLAN.....	35
A. What is chapter 11?.....	35
B. Why are the Debtors sending me this Disclosure Statement?	35
C. Am I entitled to vote on the Second Amended Plan?	35
D. What will I receive from the Debtors if the Second Amended Plan is consummated?.....	36
E. What will I receive from the Debtors if I hold an Allowed Administrative Claim, Allowed Accrued Professional Compensation Claim, Allowed Chapford DIP Facility Claim, Allowed Vida DIP Claim, Allowed DLP Secured Claim, Allowed Indenture Diminution Claim, Allowed Priority Tax Claim, or Allowed Substantial Contribution Claim?.....	41
F. Are any regulatory approvals required to consummate the Second Amended Plan?	45
G. What happens to my recovery if the Second Amended Plan is not confirmed or does not go effective?.....	46
H. If the Second Amended Plan provides that I get a distribution, do I get it upon Confirmation or when the Second Amended Plan goes effective? What is meant by “Confirmation,” “Effective Date” and “Consummation”?	46
I. Is there potential litigation related to confirmation of the Second Amended Plan?.....	46
J. Will the final amount of the allowed claims or interests in a particular class affect the recovery of holders of allowed claims or interests in such class or in other classes under the Second Amended Plan?.....	47
K. Will there be releases and exculpation granted to parties in interest as part of the Second Amended Plan?	48
L. What is the deadline to vote on the Second Amended Plan?.....	50

TABLE OF CONTENTS

(continued)

	Page
M. How do I vote for or against the Second Amended Plan?	50
N. What are the consequences of filing a late proof of claim?	50
O. Why is the Bankruptcy Court holding a Confirmation Hearing and when is the Confirmation Hearing set to occur?	51
P. Who do I contact if I have additional questions with respect to this Disclosure Statement or the Second Amended Plan?	51
Q. Do the Debtors recommend voting in favor of the Second Amended Plan?	52
R. Does the Bondholder Committee recommend that Bondholders vote in favor of the Second Amended Plan?.....	52
S. Does the Ad Hoc Broker/Dealer Committee recommend voting in favor of the Second Amended Plan?	53
IV. THE COMPANY’S CORPORATE HISTORY, STRUCTURE, AND PREPETITION BUSINESS OVERVIEW	53
A. The Company’s Corporate History and Business Overview	53
B. The Company’s Prepetition Capital Structure	63
V. EVENTS LEADING TO THE CHAPTER 11 FILINGS.....	68
A. The Company’s Financial and Legal Challenges	68
B. Defaults Under DLP IV Facility and DLP VI Facility; Amendments and Waivers	69
C. The Company’s Proactive Exploration of Strategic Alternatives.....	71
VI. MATERIAL DEVELOPMENTS AND ANTICIPATED EVENTS OF THE CHAPTER 11 CASES.....	72
A. First Day Pleadings and Other Procedural and Administrative Motions.....	72
B. Appointment of Bondholder Committee, CRO and Independent Committees; LBM; Ad Hoc Broker/Dealer Committee	75
C. Financing Matters; Filing of DLP IV and DLP VI.....	79
D. Exclusivity	86
E. Schedules and Statements	87
F. Establishment of Claims Bar Dates and Related Claims Procedures	87
G. Executory Contracts and Unexpired Leases	88
H. Litigation Matters.....	92
I. Investigations	95
J. Compensation Motion.....	100

TABLE OF CONTENTS

(continued)

	Page
VII. SUMMARY OF KEY TERMS AND CONDITIONS OF THE SECOND AMENDED PLAN	101
A. Wind Down Trust	101
B. Litigation Trust	104
C. Priority of Cash Distributions to Holders of New WDT Interests	107
D. Exemption from Registration Requirements	109
E. Releases, Exculpation and Injunction	110
F. Conditions Precedent to the Effective Date	114
VIII. RISK FACTORS	116
A. Bankruptcy Law Considerations	116
B. Risks Related to Recoveries under the Second Amended Plan and to the Wind Down Trust and Wind Down Trust Assets	120
C. Disclosure Statement Disclaimer	126
IX. SOLICITATION, VOTING PROCEDURES AND CONFIRMATION HEARING.....	128
A. Holders of Claims and Interests Entitled to Vote on the Second Amended Plan	128
B. Voting Record Date	129
C. Voting on the Second Amended Plan	129
D. Ballots Not Counted.....	130
X. CONFIRMATION OF THE SECOND AMENDED PLAN.....	131
A. Requirements for Confirmation of the Second Amended Plan	131
B. Confirmation Without Acceptance by All Impaired Classes.....	132
C. Valuation of the Wind Down Trust Assets	133
XI. CERTAIN SECURITIES LAW MATTERS.....	133
XII. CERTAIN UNITED STATES FEDERAL INCOME TAX CONSEQUENCES OF THE SECOND AMENDED PLAN	135
A. General	135
B. Consequences to the Debtors	137
C. Consequences to Holders of Claims and Interests	138
D. Tax Treatment of a Liquidating Trust and Holders of Beneficial Interests	139
E. Withholding on Distributions, and Information Reporting.....	142

EXHIBITS

- EXHIBIT A Second Amended Plan
- EXHIBIT B Disclosure Statement Order
- EXHIBIT C Valuation Analysis
- EXHIBIT D Letter from Bradley K. Heppner
- EXHIBIT E Liquidation Analysis

I. INTRODUCTION

On April 20, 2022 (the “Initial Petition Date”), GWG Holdings, Inc. (“GWGH”), GWG Life, LLC (“GWG Life”) and GWG Life USA, LLC (collectively, the “Initial Debtors”) filed voluntary petitions for relief under chapter 11 of the Bankruptcy Code. Subsequently, on October 31, 2022 (the “DLP Petition Date”²), GWG DLP Funding IV, LLC (“DLP IV”), GWG DLP Funding Holdings VI, LLC (“DLP VI Holdings”), GWG DLP Funding VI, LLC (“DLP VI”) (collectively, the “DLP Entities” and together with the Initial Debtors, the “Debtors”) also filed voluntary petitions under chapter 11 of the Bankruptcy Code (such cases, collectively with the Initial Debtors’ chapter 11 cases, the “Chapter 11 Cases”) for relief under the Bankruptcy Code. The Debtors, as debtors and debtors in possession in the above-captioned cases (together with their non-Debtor subsidiaries, collectively, the “Company”)³ submit this disclosure statement (this “Disclosure Statement”), pursuant to section 1125 of chapter 11 of title 11 of the United States Code (the “Bankruptcy Code”), in connection with the solicitation of votes for acceptance of the Debtors’ Further Modified Second Amended Joint Chapter 11 Plan (as may be amended, supplemented, or modified from time to time, the “Second Amended Plan”), submitted by the Debtors, the Official Committee of Bondholders (the “Bondholder Committee”), and L Bond Management, LLC (“LBM”) as co-proponents.⁴ A copy of the Second Amended Plan is attached hereto as **Exhibit A** and incorporated herein by reference. The Second Amended Plan constitutes a separate chapter 11 plan for each of the Debtors for the resolution of outstanding Claims and Interests pursuant to the Bankruptcy Code, and the Second Amended Plan does not contemplate substantive consolidation of any of the Debtors. The rules of interpretation set forth in Article I.B of the Second Amended Plan govern the interpretation of this Disclosure Statement.

The purpose of this Disclosure Statement is to provide information of a kind, and in sufficient detail, to enable creditors and equity holders of the Debtors that are entitled to vote on the Second Amended Plan to make an informed decision on whether to vote to accept or reject the Second Amended Plan, as required under section 1125 of the Bankruptcy Code. Holders of Claims and Interests⁵ entitled to vote to accept or reject the Second Amended Plan will receive a ballot (collectively, the “Ballots”) together with this Disclosure Statement to enable them to vote on the Second Amended Plan in accordance with the voting instructions and make any other elections or certifications required or permitted pursuant to the Second Amended Plan.

² As used herein, “Petition Date” shall refer to the applicable Petition Date with respect to such Debtor, whether that be the Initial Petition Date or the DLP Petition Date.

³ For the avoidance of doubt, the definition of the “Company” does not include The Beneficial Company Group L.P., FOXO Technologies, Inc., or their respective direct and indirect subsidiaries.

⁴ Capitalized terms used but not defined in this Disclosure Statement shall have the meaning ascribed to them in the Second Amended Plan.

⁵ The following terms are ascribed the following meanings in the Second Amended Plan:

“Holder” means any Entity holding a Claim or an Interest.

“Claim” means any “claim” (as defined in section 101(5) of the Bankruptcy Code).

“Interest” means any equity security (as defined in section 101(16) of the Bankruptcy Code) in any Debtor outstanding immediately prior to the applicable Petition Date, including any options, warrants, or other rights with respect thereto, or any other instruments evidencing an ownership interest in any of the Debtors and the rights of any Entity to purchase or demand the issuance of any of the foregoing, including: (a) redemption, conversion, exchange, voting, participation, and dividend rights (including any rights in respect of accrued and unpaid dividends); (b) liquidating preferences; and (c) stock options and warrants.

This Disclosure Statement includes, among other things: (1) an overview of the Second Amended Plan and a description of the Debtors' assets; (2) questions and answers regarding the Disclosure Statement and Second Amended Plan, including those relating to the confirmation process and procedures for voting; (3) information pertaining to the Company's corporate history, structure and prepetition business operations; (4) a description of the events leading up to the commencement of the Chapter 11 Cases; (5) a description of the material developments and anticipated events in the Chapter 11 Cases; (6) a summary of certain additional key terms and conditions of the Second Amended Plan; and (7) a discussion of certain risk factors associated with the Second Amended Plan.

THE DEBTORS (INCLUDING THE INDEPENDENT DIRECTORS) BELIEVE THAT THE SECOND AMENDED PLAN MAXIMIZES THE VALUE OF THE DEBTORS' ESTATES AND REPRESENTS THE BEST AVAILABLE OPTION FOR COMPLETING THE CHAPTER 11 CASES WITH THE HIGHEST RECOVERY FOR THE DEBTORS' SECURITY HOLDERS AND OTHER STAKEHOLDERS. THE DEBTORS RECOMMEND THAT YOU VOTE TO ACCEPT THE SECOND AMENDED PLAN.

THE BONDHOLDER COMMITTEE BELIEVES THAT THE SECOND AMENDED PLAN REPRESENTS THE BEST AVAILABLE OPTION UNDER THE CIRCUMSTANCES FOR COMPLETING THE CHAPTER 11 CASES AND RECOMMENDS THAT YOU VOTE TO ACCEPT THE SECOND AMENDED PLAN.

LBM BELIEVES THAT THE SECOND AMENDED PLAN MAXIMIZES THE VALUE OF THE DEBTORS' ESTATES FOR THE BENEFIT OF BONDHOLDERS, REPRESENTS THE BEST AVAILABLE OPTION UNDER THE CIRCUMSTANCES FOR COMPLETING THE CHAPTER 11 CASES, AND URGES YOU VOTE TO ACCEPT THE SECOND AMENDED PLAN.

THE AD HOC BROKER/DEALER COMMITTEE BELIEVES THE SECOND AMENDED PLAN MAXIMIZES THE VALUE OF THE DEBTORS' ESTATES FOR THE BENEFIT OF CREDITORS AND EQUITY INTEREST HOLDERS, REPRESENTS THE BEST AVAILABLE OPTION UNDER THE CIRCUMSTANCES FOR COMPLETING THE CHAPTER 11 CASES, AND URGES YOU VOTE TO ACCEPT THE SECOND AMENDED PLAN.

II. THE PLAN

A. Overview of the Second Amended Plan and Potential Sources of Value to Stakeholders

The proposed Second Amended Plan seeks to achieve an orderly wind-down of the Debtors' Estates that maximizes the value of all estate assets. The proposed Second Amended Plan is the culmination of more than nine months of investigations and related diligence into the Debtors' assets by the Debtors' Independent Directors and their advisors, and hard-fought post-petition negotiations regarding the structure of the Second Amended Plan that resulted in a settlement (the "Mediated Settlement") supported by the Debtors, the Bondholder Committee, and

LBM (the Bondholder Committee and LBM being referred to herein as the “Creditor Proponents”). **The Debtors (including the Independent Directors), the Bondholder Committee, LBM, and the Ad Hoc Broker/Dealer Committee all believe the Second Amended Plan represents the best possible outcome for Bondholders and urge all Bondholders to vote TO ACCEPT of the Second Amended Plan.**

As described in more detail in Article II.B.1 and Article II.C of this Disclosure Statement, the proposed wind-down under the Second Amended Plan will be achieved by creating two liquidating trusts: (i) the Wind Down Trust and (ii) the Litigation Trust. The Wind Down Trust will issue trust interests (the New WDT Interests) to Holders of Claims and Interests that are not paid in full in cash on the Effective Date of the Second Amended Plan. Holders of the New WDT Interests (including the Bondholders⁶) will receive distributions via the Wind Down Trust from *four* potential sources of value set forth in the chart below, each of which is described in more detail herein.

Asset	Description	Range of Value
Policy Portfolio	Life settlement assets, comprised of a portfolio of intermediate-duration and long-duration whole life insurance policies (each a “ <u>Policy</u> ” and collectively, the “ <u>Policy Portfolio</u> ”).	<u>Second Amended Plan</u> : ⁷ \$0 – \$78 million <u>Chapter 7 Liquidation</u> : \$0 – \$10.7 million
FOXO	Passive, non-controlling equity interests in FOXO Technologies, Inc. (“ <u>FOXO</u> ”), an independent, non-affiliated entity that operates in the epigenetics space.	<u>Second Amended Plan</u> : \$3.3 million ⁸ <u>Chapter 7 Liquidation</u> : \$2.9 million
Beneficient	Passive, non-controlling equity interests in The Beneficient Company Group, L.P. (“ <u>Ben LP</u> ” and, together with its subsidiaries, “ <u>Beneficient</u> ”), an independent, non-affiliated entity that operates in the alternative assets space.	<u>Second Amended Plan</u> : \$0 – \$1.428 billion ⁹ <u>Chapter 7 Liquidation</u> : \$0 – \$1.285 billion

⁶ As of the Initial Petition Date, and as described further in Article IV.B.2 of this Disclosure Statement, GWGH and GWG Life had outstanding Public L Bonds in the approximate amount of \$1.26 billion, Liquidity Bonds in the approximate amount of \$0.8 million (\$800,000), and Seller Trust L Bonds (as defined below) in the approximate amount of \$367 million (for a total approximate amount of \$1.627 billion). The Public L Bonds, Liquidity Bonds, and Seller Trust L Bonds are referred to herein collectively as the “Bonds,” and the holders of such Bonds are referred to herein collectively as the “Bondholders.”

⁷ Values for the Second Amended Plan are analyzed as of June 15, 2023, based on an assumed Effective Date at that time, utilizing market data as of April 14, 2023.

⁸ As described in further detail below, the value of the Debtors’ interests in FOXO is subject to market fluctuation and price volatility in the market price of FOXO’s publicly traded stock.

⁹ Based upon current information available, the Bondholder Committee believes that no weight should be given to the \$1.4 billion value.

Retained Causes of Action¹⁰	All potential claims and causes of action that arise under or relate to transactions, relationships, or conduct involving the Company and third parties, including, without limitation, Beneficent and current and former directors and officers of the Company, that occurred prior to the filing of the Chapter 11 Cases (all such causes of action that are not explicitly released by the Second Amended Plan or other Final Order shall be “ <u>Retained Causes of Action</u> ” and shall be pursued by the Litigation Trust for the benefit of all Holders of Claims and Interests).	<u>Second Amended Plan:</u> ¹¹ \$155 million – \$382 million <u>Second Amended Plan (Bondholder Committee View):</u> \$155 million – \$585 million <u>Chapter 7 Liquidation:</u> \$139.5 million – \$343.8 million
---	--	--

The Second Amended Plan is a “waterfall” Plan, which means that, in general, the Bondholders are first in line to receive distributions from the Wind Down Trust (subject to certain limited exceptions), and the Bondholders and General Unsecured Creditors, *pro rata*, are first in line to receive distributions on account of the Retained Causes of Action. Each of the sources of value has uncertainty, and the timing and amount of distributions will depend on a number of factors that are outside the control of the Debtors.

A short, plain-English summary of the treatment of the Bond Claims of Bondholders under the Second Amended Plan (the “Bondholder Summary”) is being provided to Bondholders as part of the solicitation materials and is also available free of charge at <https://www.donlinrecano.com/Clients/gwg/Dockets>. [Docket No. 1695].

1. Potential Value from the Company’s Interests in the Policy Portfolio

The Wind Down Trust will liquidate the Policy Portfolio with a view toward maximizing the value of the Policy Portfolio for the benefit of holders of the New WDT Interests. The Policy Portfolio has a *face* value of approximately \$1.6 billion as of April 14, 2023. However, because of the need for ongoing premium payments, among other things, the *actual* present value of the Policy Portfolio is significantly less than the face value. In addition, the entire Policy Portfolio is currently collateral for the Vida DIP Facility and is expected to be collateral for the Vida Exit Financing Facility. Therefore, the Wind Down Trust will only be able to realize value from the

¹⁰ LBM and the Ad Hoc Broker/Dealer Committee note that, as described in further detail in Article IV.A.4 herein, the value of certain Retained Causes of Action and the value of the Company’s interests in Beneficent are potentially inversely related. In other words, for certain of the Retained Causes of Action, if the value of Beneficent at the time of the applicable transaction was “high,” LBM believes it is more likely that the value of that particular Cause of Action will be diminished. Likewise, if the recoveries on account of the Debtors’ interests in Beneficent are high, LBM believes the damages recoverable on account of certain of the Retained Causes of Action may be reduced. Conversely, if the recoveries on account of the Debtors’ interests in Beneficent are low, LBM believes it is more likely that the damages recoverable on account of certain of the Retained Causes of Action may be increased.

¹¹ As described in Article II.A.4.i below, the range of value of the Retained Causes of Action set forth in this chart reflects a 33-67% discount rate applied by the Investigations Committee and the Bondholder Committee to address attorneys’ fees, the general risk of litigation, and potential difficulties in collection. Based upon currently available information, LBM believes that the values set forth in this chart do not adequately reflect the impact of litigation risk, attorney fees, or collectability upon the value of the Retained Causes of Action that may be available for distribution to the holders of New WDT Interests. Notwithstanding the estimates contained herein, litigation of the Retained Causes of Action may not result in any incremental distributable value to the Estates. It is, therefore, LBM’s position that the “low” value for Retained Causes of Action is \$0. Neither the Debtors nor the Bondholder Committee, which is the estate fiduciary for all Bondholders, adopt this position.

Policy Portfolio as the Vida Exit Financing Facility is paid down over time. This long-term potential cashflow from the Policy Portfolio is referred to as “residual equity interest.” As the Vida Exit Financing Facility is paid down over time, the Wind Down Trust may have an opportunity to monetize the residual equity interest of the Policy Portfolio. For example, a sale of the balance of the Policy Portfolio could result in sufficient proceeds to first pay off the balance of the Vida Exit Financing Facility and then inure to the benefit of holders of New WDT Interests.

Based on the Debtors’ estimates (which are subject to significant uncertainty as they are based upon a number of variables and assumptions), the residual equity interest in the Policy Portfolio has a present value ranging from approximately \$0 to \$78 million per an analysis of reasonably projected outcomes.

The Policy Portfolio is described further in Article IV.A.1 of this Disclosure Statement.

2. Potential Value from the Company’s Interests in FOXO

The Company holds interests in FOXO, which uses epigenetics technology for the life insurance industry (e.g., biological testing for life insurance applicants that is used to assist in the actuarial modeling of life insurance policy maturities). On September 15, 2022, FOXO merged with Delwinds Insurance Acquisition Corp. (“Delwinds”), a special purpose acquisition company, which was renamed FOXO Technologies Inc. following the merger. FOXO currently is listed on the New York Stock Exchange, and the Company owns approximately 4.6 million common shares of FOXO. The price per share of FOXO’s common stock as of market closing on April 14, 2023 was \$0.71, up \$0.38 per share for the week, which implies that the Debtors’ interests in FOXO have a value of \$3,266,000, assuming that a purchaser could be found for such interests. The FOXO stock price is entirely outside of the Company’s control. It is possible that the FOXO stock price will increase, which could result in greater recoveries for the holders of New WDT Interests on account of this asset. It is also possible that the FOXO stock price will decrease and/or that the Wind Down Trust will be unable to monetize the stock, leading to less or no recovery for the holders of New WDT Interests on account of this asset.

FOXO, the Company’s interest in FOXO, and the Delwinds merger are described further in Article IV.A.3 of this Disclosure Statement.

3. Potential Value from the Company’s Interests in Beneficient

The Company holds interests in Ben LP and Ben LP’s subsidiary Beneficient Company Holdings, L.P. (“BCH”). Beneficient endeavors to provide liquidity options to owners of alternative assets that wish to achieve an early exit from such alternative assets. As of the Initial Petition Date, the Company owned approximately 98% of the issued and outstanding common units (approximately 66 million common units) of Ben LP (prior to dilution), approximately \$319 million of preferred limited partnership interests of Ben LP and approximately \$205 million of preferred limited partnership interests of BCH. The Debtors’ common and preferred equity of Beneficient currently is junior to approximately \$1.4 billion of senior debt and senior preferred equity held by certain founders of Beneficient (which include Bradley K. Heppner, Thomas O. Hicks, Bruce W. Schnitzer, Richard Fisher, James Silk and Murray Holland (or their affiliates or entities they control)).

Beneficient, the Company's prepetition transactions with Beneficient, and the Avalon Business Combination are described further in Article IV.A.2 of this Disclosure Statement.

(a) *Impact of Potential Avalon Business Combination*

On September 21, 2022, Beneficient announced that it had signed a business combination agreement with Avalon Acquisition Inc. ("Avalon"), a publicly-traded special purpose acquisition company (such business combination transaction referred to herein as the "Avalon Business Combination," and the combined entity resulting from the Avalon Business Combination referred to herein as "New Beneficient"), as described in Ben LP's Registration Statement on Form S-4, dated April 19, 2023 (as amended, the "Ben S-4").¹² The press release issued by Beneficient and Avalon announcing the transaction asserted that the terms of the business combination agreement implied an enterprise valuation of the combined companies of \$3.5 billion, with such enterprise value based upon and relying on certain assumptions and circumstances existing on the date of such announcement (the "SPAC Implied Valuation").¹³ The Avalon Business Combination is not yet final and may or may not be completed on the terms announced or at all. The transaction is subject to certain conditions set forth in the business combination agreement that must either be satisfied or waived prior to closing. Further, the asserted \$3.5 billion implied enterprise valuation with respect to the SPAC Implied Valuation may or may not prove to be accurate. To the extent the Avalon Business Combination is consummated, and to the extent the SPAC Implied Valuation is accurate, the Company's interests in Beneficient would result, upon completion of the Avalon Business Combination, in an ownership interest in New Beneficient with a nominal value equal to approximately \$1.4 billion.

Such nominal value, however, may or may not result in distributable value to the Estates. The value of the Company's equity interests in New Beneficient will be subject to constant public market valuation and re-valuation after the consummation of the Avalon Business Combination as a result of such equity interests being listed on a national stock exchange, and could be worth significantly less. It is important to note that market prices associated with equity interests issued in connection with the consummation of business combinations with special purpose acquisition companies have been particularly volatile over the last twelve months. Furthermore, it is possible that the federal securities laws will create limitations on the Wind Down Trust's ability to dispose of the equity interests in New Beneficient received by the Company upon consummation of the Avalon Business Combination. These restrictions, or other restrictions that may be imposed, may further reduce or eliminate any value associated with such equity interests.

¹² The Ben S-4 is available on the SEC's website by using the following weblink: <https://www.sec.gov/Archives/edgar/data/1775734/000119312523106636/d406382ds4a.htm>.

¹³ The Debtors have not reviewed any non-public projections or business plans underlying the Avalon Business Combination and, therefore, cannot address their accuracy or veracity, and as a result, also cannot opine on the accuracy or veracity of the SPAC Implied Valuation, or the likelihood that such SPAC Implied Valuation will be achieved in a timely manner or ever. As noted, this is an implied valuation asserted by Beneficient and Avalon, and it is not the Debtors' valuation. Furthermore, based on information the Bondholder Committee has received to date, the Bondholder Committee neither agrees with nor adopts the purported \$3.5 billion valuation, nor the implied valuation of the Company's interests in Beneficient upon completion of the Avalon Business Combination, should it occur. Further, for the avoidance of doubt, no statements contained herein shall be deemed binding on the Litigation Trust in any respect.

Additionally, upon completion of the Avalon Business Combination, the Company's equity interests will be junior to approximately \$1.2 billion¹⁴ of senior debt and senior preferred equity held by certain founders of Beneficient (or their affiliates or entities they control). In addition, notwithstanding the Wind Down Trust's expected sizable ownership stake in Beneficient, the Wind Down Trustee will have limited ability to influence the management of Beneficient as a result of the fact that Beneficient will issue a separate class of common stock which will have the right to appoint a majority of the combined company's board of directors. As a result, Beneficient may incur additional debt or issue securities that rank senior to, or pari passu with, the Wind Down Debtors' expected interests in Beneficient following the Avalon Business Combination.¹⁵

(b) *The Value of the Company's Interests in Beneficient is Uncertain, Whether or Not the Avalon Business Combination is Consummated*

The Debtors have not been able to obtain either a business plan or financial projections for Beneficient. As such, the Debtors neither can perform their own valuation analysis of Beneficient nor independently verify the announced \$3.5 billion valuation, including whether such SPAC Implied Valuation remains current from the perspective of Avalon or Beneficient.

There are certain benefits that New Beneficient may enjoy if the Avalon Business Combination is consummated and which are currently unavailable to Beneficient as a private company. For example, as a publicly listed company with equity securities listed on a nationally recognized exchange, New Beneficient may be able to attract additional investment that would be otherwise unavailable to it as a private company, and such additional investment may be accretive to the Wind Down Debtors if such investment allows New Beneficient to execute on any proposed business plans, refinance existing debt or other securities, and/or generally continue as an ongoing enterprise. In addition, if the Avalon Business Combination is consummated such that the Company would hold equity securities listed on a nationally recognized exchange, it could improve the ability of the Wind Down Trust to monetize the Company's interests in New Beneficient.

There are, however, numerous risk factors disclosed by Beneficient in the Ben S-4 that could materially impact the value of the Company's interests in Beneficient and/or Beneficient's ability to consummate the Avalon Business Combination, including the following:

- The Avalon Business Combination contemplates that each existing Avalon share of common stock will effectively convert into 1.25 shares of Beneficient common stock at a price of \$10.00 per share.¹⁶ The Avalon common stock traded at \$10.48

¹⁴ In connection with the Avalon Business Combination, certain founders of Beneficient (or the affiliates or entities they control) will convert approximately \$194 million of their senior preferred equity into common equity of New Beneficient, resulting in a lower aggregate amount of senior debt and senior preferred equity following the Avalon Business Combination than the approximate amount (\$1.4 billion) prior to such transaction.

¹⁵ LBM notes that, while the existence of senior debt or equity interests could impact the market price of any publicly traded New Beneficient equity interests, the existence of such senior interests will not otherwise restrict the ability of the Wind Down Trust to liquidate such publicly traded interests that may be received on account of the Company's existing interests in Beneficient.

¹⁶ Each existing Avalon share of common stock automatically will be converted into one share of Beneficient common stock, and as additional merger consideration, each holder of Avalon Class A common stock will also

as of market close on April 14, 2023. Avalon warrants, which provide the warrant holder with the right to purchase shares of Beneficient after the closing of the Avalon Business Combination for \$11.50 per share and are not subject to any cash redemption feature in connection with the closing of the Avalon Business Combination, traded at \$0.09 as of market close on April 14, 2023.

- There can be no assurance as to the market value of the Company's interests in Beneficient following the Avalon Business Combination (if consummated). The Debtors believe it is important to note that Beneficient disclosed that, as part of its business plan, it "expects to issue additional equity securities . . . resulting in the dilution of the ownership interests of its present stockholders," which would include the Company. *See* Ben S-4, at 47.
- Beneficient disclosed that its business "may be negatively impacted by changes in general economic and market conditions including, but not limited to, changes in interest rates." *See* Ben S-4, at 86.
- Beneficient disclosed that it has "not historically generated positive cash flow from operations" and "believe[s] that [it] will need substantial additional capital to fund [its] business plan." *See* Ben S-4, at 90-91. The Debtors are unaware of any third parties that have agreed to make a significant cash investment in Beneficient and, therefore, it is uncertain whether Beneficient will be able to obtain the "substantial additional capital" it needs. Beneficient disclosed that if it is "unable to obtain capital . . . [Beneficient] may be unable to continue building [its] business and as a result may be required to scale back or cease operations for [its] business, the result of which may be that you could lose some or all of your investment." *See* Ben S-4, at 91.
- Beneficient disclosed that the Company is under an active investigation by the SEC, which has sought information related to, among other things, the issuance of Bonds, the consolidation for financial reporting purposes of Beneficient and the Company, goodwill valuation, accounting related to the trusts through which Beneficient operates its business, related party transactions, and the calculation of the debt-coverage ratio. *See* Ben S-4, at 60. The Debtors believe it is important to note that many of the matters under investigation by the SEC occurred while certain individuals expected to serve as New Beneficient's executive officers and directors were directors of GWGH, including Brad K. Heppner, who was Chairman of the Board of GWGH from April 2019 through July 2021. According to Beneficient, Avalon may terminate the Avalon Business Combination if the SEC investigation results in the "reasonable likelihood" that the Avalon Business Combination cannot occur. *Id.* Specifically, Beneficient disclosed that, "[i]f the SEC were to seek an injunction, the closing of the Business Combination could be delayed or may not occur." *Id.* The Debtors believe it is important to note that national stock exchanges in the United States have discretionary authority to deny listing applications in

receive one share of Beneficient Series A Convertible Preferred Stock, which will be convertible into 0.25 shares of Beneficient common stock.

certain circumstances, including for regulatory or other concerns regarding an applicant, and listing on such a national stock exchange is a condition to the closing of the Avalon Business Combination. Furthermore, even if the Avalon Business Combination is consummated, any perceived “overhang” from such SEC investigations, pending or threatened litigation, or other regulatory matters may result in a materially depressed share price until any or all such matters are resolved. If such matters are conclusively determined in an adverse manner subsequent to the consummation of the Avalon Business Combination, it could potentially result in the de-listing, removal, or prohibition on trading of New Beneficient common stock on a nationally recognized stock exchange or in the “over-the-counter” market, or monetary and/or other penalties imposed by the SEC or other regulators, which may include injunctions or enforcement actions which prevent key members of management from serving as officers or directors of New Beneficient and/or related enterprises.

- Beneficient disclosed that “it is possible that the Kansas legislature could adopt further amendments” to relevant legislation “that may adversely affect [Beneficient’s] business plans and operations which could adversely affect [its] financial performance and prospects.” *See* Ben S-4, at 53.
- Beneficient disclosed the possibility that claims or causes of action arising from Beneficient’s prepetition transactions and business dealings with the Company (for example, the Retained Causes of Action) “could be advanced against [Beneficient] as part of the Chapter 11 Cases or in separate litigation.” *See* Ben S-4 at 57-58. According to Beneficient, such litigation, or even the mere “potential for such litigation” to be pursued, “could have a material adverse effect on [Beneficient’s] operations, financial condition, or ability to close the Business Combination Agreement, and could result in a decline of the perceived value of [Beneficient], which could ultimately be reflected as a reduction in the market price of [Beneficient’s] securities.” *Id.* at 58. The Debtors believe it is important to note that litigation against Beneficient relating to its prepetition transactions with the Company is already being pursued. For example, on March 30, 2023, Plaintiffs David Scura and Clifford Day filed a putative class action lawsuit in the United States District Court for the Northern District of Texas (Dallas Division) against, among other defendants, Ben LP, Brad K. Heppner, and other former directors of GWGH affiliated with Beneficient, asserting that such defendants violated federal securities laws. The Debtors believe that such litigation, and/or the pursuit of the Retained Causes of Action by the Litigation Trust, could adversely impact the value of the Company’s interests in Beneficient to the extent the value of those interests is material.

For more information regarding risk factors associated with Beneficient, Holders of Claims and Interests are encouraged to review the Ben S-4 filed with the SEC and any further amendments thereto, including, but not limited to, the section titled “Risk Factors.”

(c) Range of Value and Relevance of the SPAC Implied Valuation

As set forth in more detail in the Valuation Analysis, the Debtors estimate the value of the Debtors' interests in Beneficient ranges from \$0 to \$1.428 billion. The Debtors recognize this is a large range but believe it is warranted given the uncertainty and lack of information regarding Beneficient. The potential for the Avalon Business Combination to be consummated, while relevant, does not necessarily provide any additional certainty regarding the value of the Debtors' interests in Beneficient. Although the Debtors have used the SPAC Implied Valuation as the high end of the range of potential value, the Debtors believe it is important to note that the SPAC Implied Valuation was the result of negotiations between Beneficient and Avalon. The Debtors do not have sufficient information to perform an independent valuation analysis. Based upon current information available, the Bondholder Committee believes that no weight should be given to the SPAC Implied Valuation.

Furthermore, notwithstanding the potential nominal value of the Company's interests in Beneficient, the Wind Down Trust's ability to monetize such interests in an amount that approximates that nominal value will be determined by the market's valuation of those interests at the time of monetization and, to the extent a third-party buyer can be found, will be limited by trading restrictions and the difficulty of monetizing such a large percentage of the equity interests in Beneficient. This will likely result in a substantial delay before the Wind Down Trust can realize any distributable value from the Company's interests in Beneficient.¹⁷

The Debtors' investment banker PJT has prepared the following sensitivity which shows the impact to the recovery of Class 3 Bondholder Claims from various hypothetical future realized per share values for New Beneficient. This analysis shows the impact on recovery solely with respect to the Beneficient interests, without considering the Estates' other assets and their impact on recovery. This analysis is a sensitivity for illustrative purposes only, should be considered in connection with all of the risk factors described in this Disclosure Statement and in the Bondholder Summary, and does not express any opinion of PJT as to the likelihood of New Beneficient equity trading below, above, or at any point illustrated below or the likelihood that the recovery percentages with respect to such Beneficient interests will be as set forth below.

Sensitivity of Hypothetical Recovery Attributable to Beneficient Equity	(\$ in mm)					
	Hypothetical Beneficient Share Price					
	\$ -	\$ 2.00	\$ 4.00	\$ 6.00	\$ 8.00	\$ 10.00
Hypothetical Beneficient Value to GWG ⁽¹⁾	\$ -	\$ 286	\$ 571	\$ 857	\$ 1,143	\$ 1,428
Hypothetical Portion of Class 3 - Bondholder Claims Recovery % Attributable to Beneficient Equity Owned by GWG	-	17.1%	34.1%	51.2%	68.2%	85.3%

Notes:

(1) Calculated as the number of the Debtors' shares in New Beneficient at SPAC transaction (142.8 million) multiplied by illustrative New Beneficient share price.

¹⁷ For the avoidance of doubt, the valuation of the Debtors' interests in Beneficient is for Second Amended Plan purposes only, does not purport to reflect the value of Beneficient at the time of any prepetition transaction and shall not in any way be binding on the Litigation Trust or in any way prejudice, or be deemed an admission by, the Litigation Trust in connection with the pursuit of any Retained Causes of Action or any other litigation.

4. Potential Value from the Retained Causes of Action

The independent investigations by the Investigations Committee and/or the Bondholder Committee (collectively, the “Investigations”) have identified certain colorable litigation claims and causes of action that arise under or relate to transactions, relationships, or conduct involving the Company and third parties, including prepetition advisors, which will be transferred to, retained by, and vest in the Litigation Trust in connection with the Second Amended Plan.¹⁸ All of the potential causes of action belonging to the Debtors or their Estates that are not released pursuant to the Second Amended Plan or other Final Order are defined in the Second Amended Plan as Retained Causes of Action.¹⁹ A description of certain of the Retained Causes of Action, and the potential damages that could be recoverable in litigation, is set forth below.²⁰

(a) *Claims Arising from the Beneficient Separation Transactions*

In November 2021, the Company relinquished its control of Beneficient and exchanged certain debt and preferred equity interests in Beneficient for common equity and a new tranche of preferred equity interests in Beneficient. The Beneficient Separation Transactions are described in greater detail in Article IV.A.2.b of this Disclosure Statement.

The Investigations concluded that there are potential claims against Beneficient, as well as their advisors and professionals, for constructive fraudulent transfers with respect to the transfer of control of Beneficient and the exchange of debt and equity interests for less than reasonably equivalent value. Further, there is evidence to support allegations that the conflicted fiduciaries who structured and negotiated the Beneficient Separation Transactions did so with intent to hinder, delay, or defraud the Company’s creditors, which would support actual fraudulent transfer claims. In addition, the Investigations concluded that there are potential claims against certain former directors and officers of GWGH for breaches of fiduciary duty in connection with the Beneficient

¹⁸ LBM has received limited information related to the investigations and conclusions of the Investigation Committee and the Bondholder Committee as to the existence of colorable claims. As such, LBM neither joins with nor adopts the positions of any of the Debtors, the Investigations Committee, or the Bondholder Committee. Further, other than to note its previously expressed disagreement with the characterization of certain facts as set forth in the Bondholder Committee’s Standing Motion, LBM expresses no opinion regarding the merits of any alleged claims. As noted herein, however, LBM and the Ad Hoc Broker/Dealer Committee disagree with certain assumptions of the Investigations Committee and the Bondholder Committee regarding the potential distributable value of the Retained Causes of Action.

¹⁹ For the avoidance of doubt, all potential claims and causes of action against the proposed defendants asserted in the Committee’s Standing Motion and the Proposed Complaint attached thereto are among those that will be included as Retained Causes of Action, unless explicitly released pursuant to the Second Amended Plan, including pursuant to the LBM Settlement. All parties in interest should also review the schedule of the known Retained Causes of Action, which will be filed as part of the Plan Supplement and will include such potential claims and others against the proposed defendants (and other potential defendants) not explicitly released.

²⁰ The description set forth herein is non-exclusive. The Investigations Committee and the Bondholder Committee reserve the right to alter, modify, amend, remove, augment, or supplement this description at any time in accordance with the Second Amended Plan, and the Litigation Trust shall have the right to pursue any and all Retained Causes of Action regardless of whether they are described below and shall not be limited or prejudiced in any respect by anything contained in this Disclosure Statement, nor shall the Litigation Trust be deemed to adopt any statements contained herein.

Separation Transactions, and potential claims against Beneficient and/or certain directors and officers of Beneficient for aiding and abetting such breaches of fiduciary duty.

The damages suffered by the Company depend upon the value of Beneficient at the time of the transaction, which impacts the value of the control premium and the value of the debt and equity interests that were exchanged. Specifically, the Investigations concluded that the Company should have received up to approximately \$466 million in exchange for relinquishing control of Beneficient. The damages associated with the control premium are *directly* correlated with the value of Beneficient at the time of the transaction because, as the value of Beneficient increases, the value of the control over the Beneficient enterprise would also increase. In addition, the Investigations concluded that the Company suffered damages up to approximately \$208 million as a result of the debt and equity exchanges. In general, these damages are inversely correlated with the value of Beneficient because, as the value of Beneficient increases, the preferred equity interests received by the Company are more likely to provide value to the Company. Accordingly, the potential damages for relinquishing control of Beneficient and the debt/equity exchanges would not be cumulative. Finally, the potential damages to the Company also include approximately \$40 million that was incurred by the Company to resolve the default under the DLP IV credit facility that resulted from the Beneficient Separation Transactions.²¹

(b) *Claims Arising from the Company's Investments in Beneficient*

From May 2019 through March 2021, the Company invested approximately \$300 million in Beneficient in exchange for common equity and preferred equity interests in Beneficient. These investments include:

- *LiquidTrust Promissory Note.* Advances of \$65 million in the aggregate in June and November 2019 pursuant to the LiquidTrust Promissory Note, which was repaid in September 2020 in Preferred Series C interests in BCH (the “Preferred C Units”).
- *June 2019 Acquisition.* Purchase of 1 million units of common equity in Beneficient in June 2019 from Essex Woodlands Health Venture Fund IV LP and Essex Woodlands Health Venture Fund VI LP (collectively, “Essex”) at a price of \$10 per unit for a total purchase price of \$10 million.
- *2019 Capital Contribution.* Purchase of: (i) 666,667 units of common equity in Beneficient at a price of \$15 per unit for a total purchase price of approximately \$10 million; and (ii) Preferred Series A interests in BCH (the “Preferred A Units”) for a total purchase price of approximately \$69 million.
- *2020 and 2021 Capital Contributions.* Purchases of additional Preferred C Units pursuant to the Unit Purchase Agreement, dated July 15, 2020 (the “UPA”), for a total purchase price of approximately \$145 million in the aggregate, in purchases made in July 2020, September 2020, October 2020, December 2020, and March 2021.

²¹ The default under the DLP IV credit facility that resulted from the Beneficient Separation Transactions is described in greater detail in Article V.B.1 of this Disclosure Statement.

The Company's investments in Beneficient, including the LiquidTrust Promissory Note and subsequent repayment, the June 2019 Acquisition, the 2019 Capital Contribution, and the 2020 and 2021 Capital Contributions (collectively, the "Ben Investments"), are described in greater detail in Article IV.A.2.b of this Disclosure Statement.

The Investigations concluded that there are potential claims against Beneficient for constructive and/or actual fraudulent transfers with respect to each of the Ben Investments, particularly to the extent the Company received less than reasonably equivalent value in each transaction. In addition, the Investigations concluded that there are potential claims against certain former directors and officers of GWGH for breaches of fiduciary duty in connection with the Ben Investments, and potential claims against Beneficient and/or certain directors and officers of Beneficient, or other third parties, for aiding and abetting such breaches of fiduciary duty or other claims, as well as claims against Beneficient's advisors and professionals.

To the extent the Ben Investments are avoided as constructive and/or actual fraudulent transfers, the value transferred by the Company could be recovered from Beneficient (as the initial transferee or the entity for whose benefit each transfer was made), Essex (in the case of the June 2019 Acquisition), or certain subsequent transferees of Beneficient. Specifically, the Investigations found that Ben used approximately \$175 million of the amounts received in connection with the Ben Investments to redeem debt or equity securities, including debt or equity securities held by related parties of Beneficient.

The damages suffered by the Company depend upon the value of Beneficient at the time of the transactions in question, which impacts the value of the interests that the Company obtained in connection with the Ben Investments. Specifically, the Investigations concluded that the Company suffered damages up to approximately \$299 million in connection with the Ben Investments.

(c) Claims Arising from the Subordination of the Preferred C Units

At issuance, the Preferred C Units owned by the Company ranked equal in priority with the Preferred A Units. The equal priority of the Preferred C Units and the Preferred A Units was a specific term that was negotiated between Beneficient and a former special committee of independent directors of the GWGH board, as provided in the Fifth Amended and Restated Limited Partnership Agreement of BCH, dated July 15, 2020 (the "5th LPA"). All of the Preferred C Units held by the Company were issued to the Company while the 5th LPA was in effect. Following the dissolution of the former special committee, BCH executed the Sixth Amended and Restated Limited Partnership Agreement of BCH, effective as of March 31, 2021 (the "6th LPA"), which superseded the 5th LPA. The 6th LPA subordinated all of the previously-issued Preferred C Units behind all of the Preferred A Units, which are now held entirely by insiders of Beneficient. The Company's purported consent to this subordination was executed by a conflicted fiduciary on November 5, 2021, more than seven months after the purported effective date of the 6th LPA. The subordination of the Preferred C Units that was effectuated by the 6th LPA was not disclosed publicly and may have been concealed from certain directors of GWGH.

The Investigations concluded that there are potential claims against Beneficient for constructive and actual fraudulent transfers with respect to the subordination of the Preferred C

Units in connection with the 6th LPA. Further, there is evidence to support allegations that the conflicted fiduciaries who structured and provided the Company's consent to the 6th LPA did so with intent to hinder, delay, or defraud the Company's creditors, which would support actual fraudulent transfer claims. In addition, the Investigations concluded that there are potential claims against certain former directors and officers of GWGH for breaches of fiduciary duty in connection with the 6th LPA, and potential claims against Beneficient and/or certain directors and officers of Beneficient for aiding and abetting such breaches of fiduciary duty. Finally, there are potential claims that the 6th LPA was not valid because it was not properly approved by the Company, which could invalidate the 6th LPA and any subsequent Limited Partnership Agreements of BCH.

The damages suffered by the Company depend upon the value of Beneficient at the time of the transactions, which impacts whether the subordination of the Preferred C Units changed their value. Specifically, the Investigations concluded that the Company suffered damages in connection with the subordination of the Preferred C Units up to approximately \$205 million, *i.e.*, the face amount of the Preferred C Units owned by the Company as of December 31, 2022.

(d) Claims Arising from the March 2021 8-K

As described in greater detail in Article VI.I.4 of this Disclosure Statement, GWGH filed a Current Report on Form 8-K on March 11, 2021, which the Investigations Committee concluded incorrectly stated that the resignations of certain directors who had been the members of a former special committee of independent directors of the GWGH board were not due to any disagreement with GWGH. The Investigations concluded that there are potential claims against certain former directors and officers of GWGH for breaches of fiduciary duty in connection with the March 2021 8-K, and potential claims against Beneficient and/or certain directors and officers of Beneficient, or other third parties, for aiding and abetting such breaches of fiduciary duty or other claims. The Investigations concluded that such potential damages could be approximately \$4 million to approximately \$46 million.

(e) Claims Arising from the October 2019 8-K

GWGH filed a Current Report on Form 8-K on October 21, 2019, which disclosed the following as the reason for the resignation of three directors of GWGH and Beneficient:

As a result of discussions among members of the Board of Directors ... and based in part on a determination that a Board comprised of fewer directors would facilitate that Board's ability to oversee future Company activities in an efficient and effective manner ... David H. Glaser, Sheldon I. Stein and Bruce E. Zimmerman [(the "2019 Resigning Directors")]] resigned from the Board and the size of the Board was reduced from 14 to ten directors.

Prior to their resignations, the 2019 Resigning Directors expressed concerns in writing regarding the Company's business plan, forecasted cash flows, and proposed investments in Beneficient. The 2019 Resigning Directors generally opposed the transfer of the Company's funds to Beneficient and urged a moratorium on funds being sent from the Company to Beneficient.

When they were unsuccessful in those efforts, the 2019 Resigning Directors resigned. Thereafter, former Chief Executive Officer of the Company, Murray T. Holland, contacted the 2019 Resigning Directors and asked them to withdraw their resignations in favor of the board reducing its size and removing them. The 2019 Resigning Directors agreed to that proposal and also agreed to the contents of the October 2019 8-K.

The Investigations concluded that there are potential claims against certain former directors and officers of GWGH for breaches of fiduciary duty and other claims in connection with the October 2019 8-K, which may contain misrepresentations or omissions, and potential claims against Beneficient and/or certain directors and officers of Beneficient, or other third parties, for aiding and abetting such breaches of fiduciary duty or other claims. The Investigations concluded that such potential damages could be approximately \$22 million.

(f) Claims Arising from the 2018 Special Dividend

In connection with the Exchange Transaction, which is described in greater detail in Article IV.A.2.b of this Disclosure Statement, GWGH issued a \$25.7 million special dividend to its shareholders (the “2018 Special Dividend”), including Jon R. Sabes (former Chief Executive Officer and director of GWGH) and Steven F. Sabes (former Executive Vice President and director of GWGH). The Investigations concluded that there are potential claims under Delaware law against Jon Sabes, Steven Sabes, and the directors who approved the 2018 Special Dividend to recover the full amount of the 2018 Special Dividend.

(g) “Ponzi Scheme” Allegations by the Bondholder Committee

As described in greater detail in Article IV.A.2.b of the Disclosure Statement, in April 2019, Beneficient effectively took control of the Company by obtaining the right to appoint a majority of the GWGH board. Shortly thereafter, GWGH stopped purchasing new life insurance policies and increased sales of Bonds. The proceeds of Bonds purchased by subsequent investors were used, in part, to pay prior series of Bonds. The Beneficient-affiliated directors who caused the Company to pursue this business model knew that the Company would have to sell yet more new Bonds to repay its increasing debt, while relying on projections that showed the increasing debt would only be sustainable if the Company realized a significant return on its investments in Beneficient.

The Bondholder Committee’s investigation concluded that this business model had the hallmarks of a Ponzi scheme. As a result, it believes there are potential claims against certain former directors and officers of GWGH for breach of fiduciary duty for overseeing and perpetrating a Ponzi scheme. While the potential damages to the Company arising from such potential claims are difficult to quantify, the Bondholder Committee’s investigation concluded that such potential damages could be up to approximately \$877 million, which is the face amount of Public L Bonds sold from April 2019 through the Petition Date.

The Bondholder Committee’s investigation also concluded that GWGH paid at least \$38 million in commissions and other payments to certain Broker Dealers since April 2019. As such,

there are potential claims against Broker Dealers for those commissions and payments as an intentional fraudulent transfer.²²

The Ad Hoc Broker/Dealer Committee vehemently asserts that no claims or causes of action exist against the Broker Dealers, whether related to the Bondholder Committee's "Ponzi scheme" allegations or otherwise. Even if any such causes of action do exist, the Ad Hoc Broker/Dealer Committee asserts that valid defenses exist for use on their behalf. Furthermore, the Ad Hoc Broker/Dealer Committee asserts that the commencement of any actions against the Broker Dealers will give rise to indemnification claims against the Debtors and the Debtors' Estates, and the incurrence of significant fees and expenses on behalf of the Debtors.

Moreover, the Ad Hoc Broker/Dealer Committee believes that the Bondholder Committee's allegation that the Company acted as a "Ponzi scheme" is unsubstantiated.

(h) Quantification of Potential Damages

The chart below sets forth a summary of the estimated range of potential damages from each of the Retained Causes of Action. Because the potential damages associated with certain of the Retained Causes of Action depend in significant part on the assumed valuation of the Company's interests in Beneficient at the time of the related transfer or transaction, the chart below presents the potential damages at a range of illustrative valuations: from a "Low" valuation assuming approximately the book value of Beneficient's assets at the time of each transaction to a "High" valuation assuming approximately the valuation attributed to Beneficient by its own advisors at the time of each transaction.

²² There may be additional potential claims for fraudulent transfer associated with other transfers that are not described herein. Nothing in this Disclosure Statement should be seen as limiting any claims or causes of actions that may be pursued by the Litigation Trust.

Certain Retained Causes of Action	Estimated Damages	Estimated Damages
	Low Beneficient Valuation	High Beneficient Valuation
Claims Arising from the Beneficient Separation Transactions ²³	\$151-206 million	\$272-505 million
Claims Arising from the Ben Investments and/or the Subordination of the Preferred C Units ²⁴	\$261-299 million	\$0
Claims Arising from the March 2021 8-K ²⁵	\$4-46 million	\$4-46 million
Claims Arising from the October 2019 8-K ²⁶	\$22 million	\$22 million
Claims Arising from the 2018 Special Dividend ²⁷	\$26 million	\$0
ESTIMATED TOTAL	\$464-\$599 million	\$298-\$573 million
Ponzi Scheme Allegations by the Bondholder Committee	\$877 million	\$0
ESTIMATED TOTAL WITH PONZI SCHEME ALLEGATIONS	\$464-\$877 million	\$298-\$573 million

(i) Analysis of Potential Recoveries from Pursuit of the Retained Causes of Action

As stated above, the potential damages associated with certain of the Retained Causes of Action depend in significant part on the assumed valuation of the Company's interests in Beneficient at the time of the transaction. The Investigations Committee and the Bondholder Committee currently value the gross potential damages to the Company that could reasonably be asserted in pursuing the Retained Causes of Action (excluding potential damages associated with Ponzi Scheme allegations) to be between \$464 million and \$599 million assuming a "Low" valuation of Beneficient and \$298 million and \$573 million assuming a "High" valuation of Beneficient, in each case as described above.

In estimating potential recoveries of incremental distributable value by the Estates, the Investigations Committee and the Bondholder Committee believe it is appropriate to apply a 33-67% discount rate to address: (i) contingency counsel fees; (ii) the general risk of litigation; (iii) that some portion of the D&O Liability Insurance Policies may not be recoverable;²⁸ and (iv) potential issues with collectability.²⁹

²³ As described in [Article II.A.4.a](#) of this Disclosure Statement.

²⁴ As described in [Article II.A.4.b-c](#) of this Disclosure Statement.

²⁵ As described in [Article II.A.4.d](#) of this Disclosure Statement.

²⁶ As described in [Article II.A.4.e](#) of this Disclosure Statement.

²⁷ As described in [Article II.A.4.f](#) of this Disclosure Statement.

²⁸ The Debtors are beneficiaries of D&O Liability Insurance Policies which provide coverage to the Company, Beneficient and the Company's current and former officers and directors, as described further in [Article VI.G.4](#) of this Disclosure Statement. As of March 7, 2023, there is approximately \$146 million in available coverage under D&O Liability Insurance Policies for acts occurring prior to the Initial Petition Date. The D&O Liability Insurance Policies are "wasting policies," meaning that the amount of available coverage to fund any settlement or judgment will likely be further reduced by the defense costs incurred by insured defendants.

²⁹ LBM asserts that the stated discount rate does not adequately account for the cost of litigation or the degree of risk inherent in litigation. For example, LBM believes that cost of litigation may reduce recoveries by as much as 25% – 40% plus reimbursement of expenses. With this assumption and based on currently available information, LBM believes that the risk allocation for the remaining factors is significantly understated. In particular, as to any

Accordingly, the Investigations Committee and the Bondholder Committee believe that distributable value to the estate from litigation of the Retained Causes of Action (excluding potential damages associated with Ponzi Scheme allegations), in the form of recoveries from the D&O Liability Insurance Policies and from putative third-party defendants, could result in between \$155 million and \$399 million assuming a “Low” valuation of Beneficient and \$99 million and \$382 million assuming a “High” valuation of Beneficient. The Bondholder Committee further believes that, taking into account the potential damages associated with Ponzi Scheme allegations, the distributable value from the litigation may be up to \$585 million assuming a “Low” valuation of Beneficient.

Importantly, neither the Investigations Committee nor the Bondholder Committee makes any representation as to whether the Litigation Trust will ultimately be successful or unsuccessful in pursuit of any of the Retained Causes of Action. Litigation is inherently uncertain and the ability of the Litigation Trust to collect the potential damages set forth herein will depend upon a number of factors, including the probability of success in litigation, the difficulties in collection, and the expense and delay of litigation. These factors are not entirely within the Litigation Trust’s control and, notwithstanding the estimates contained herein, litigation of the Retained Causes of Action may not result in any incremental distributable value to the Estates.

Mr. Brad K. Heppner, Beneficient Company Holdings, L.P., and the Beneficient Company Group, L.P., each of whom is a potential defendant in litigation that may be pursued by the Litigation Trust, vigorously dispute the merits of the allegations made with respect to the Retained Causes of Action and in the Bondholder Complaint as well as the valuations ascribed to those alleged claims in the Disclosure Statement. Mr. Heppner’s counsel has put forth Mr. Heppner’s position, in which Beneficient Company Holdings L.P. and Beneficient Company Group, L.P. join, in a letter attached hereto as **Exhibit D**. For the avoidance of doubt, the Debtors, the Investigations Committee, and the Bondholder Committee do not adopt or agree in any way with the statements or arguments contained in that letter. However, as directed by the Bankruptcy Court in order to resolve certain objections to this Disclosure Statement, such letter is attached hereto as **Exhibit D**.

5. Recoveries Under a Hypothetical Chapter 7 Liquidation

The Debtors believe that liquidation under chapter 7 of the Bankruptcy Code—a very possible event if the Second Amended Plan is not confirmed—would result in significantly reduced creditor recoveries as compared to the Second Amended Plan. Smaller recoveries would result because of, among other things, significant additional administrative expenses associated with the appointment of a chapter 7 trustee and administration of a chapter 7 liquidation, including additional claims that may be entitled to administrative priority and the statutory compensation that a chapter 7 trustee is entitled to.

The Liquidation Analysis attached hereto as **Exhibit E** sets forth the Debtors’ advisors estimated recoveries for each Class of Claims and Interests that may be realizable upon the disposition of assets pursuant to a hypothetical chapter 7 liquidation of the Debtors’ Estates, and

potential damages amounts exceeding the remaining available coverage under the D&O Liability Insurance Policies, LBM believes that there is a substantial likelihood that the Estates will receive as little as \$0 in recovery of such potential damages.

compares such estimated recoveries with the estimated recoveries available under the Second Amended Plan. As shown in the below chart comparing those estimated recoveries, the Debtors predict that Holders of Bond Claims and General Unsecured Claims will receive more under the Second Amended Plan than in a hypothetical chapter 7 scenario.

Asset	Description	Range of Value
Policy Portfolio	Values under the Second Amended Plan	\$0 – \$78 million
	Values in a Chapter 7 Liquidation	\$0 – \$10.7 million
FOXO	Values under the Second Amended Plan	\$3.3 million
	Values in a Chapter 7 Liquidation	\$2.9 million
Beneficient	Values under the Second Amended Plan	\$0 – \$1.428 billion
	Values in a Chapter 7 Liquidation	\$0 – \$1.285 billion
Retained Causes of Action	Values under the Second Amended Plan	\$155 million – \$382 million
	Values in a Chapter 7 Liquidation	\$139.5 million – \$343.8 million
Class		Estimated Recoveries
Bond Claims³⁰	Estimated Total Recovery under Second Amended Plan	9.0% – 100%
	Estimated Total Recovery under a Chapter 7 Liquidation	3.9% – 94.2%
General Unsecured Claims	Estimated Total Recovery under Second Amended Plan	8.5% – 21.9%
	Estimated Total Recovery under a Chapter 7 Liquidation	4.1% – 19.7%
Chapter 11 Total Recovery in Excess of Chapter 7 Total Recovery		\$34.4 million – \$314 million

B. Mediation and Related Resolutions

The Debtors filed an initial chapter 11 plan on December 1, 2022 (the “Initial Plan”) and an amended chapter 11 plan on February 10, 2022 (the “First Amended Plan”), each along with an accompanying disclosure statement. The Debtors filed the Initial Plan and First Amended Plan understanding that, while there was agreement among several of the Debtors’ constituencies on the general framework of a chapter 11 plan, significant issues still remained open. Therefore, the Debtors and the Special Committee filed the *Motion of the Debtors and the Special Committee of the Board of GWG Holdings, Inc. for Entry of an Order (I) Appointing a Judicial Mediator, (II) Requiring Parties to Maintain Confidentiality of Mediation Communications and (III) Granting Related Relief* [Docket No. 1128] (the “Plan Mediation Motion”) seeking the appointment of the Honorable David R. Jones, United States Bankruptcy Judge for the Southern District of Texas, as judicial mediator (the “Mediator”) to assist the Debtors in reaching a consensual chapter 11 plan. The Plan Mediation Motion was entered on January 5, 2023 [Docket No. 1323] and identified the following parties that agreed to participate in the Mediation: (a) the Debtors, (b) the Independent Directors, (c) the Bondholder Committee, (d) Beneficient, (e) LBM, (f) the Ad Hoc Broker/Dealer

³⁰ The provided estimated recoveries exclude LBM L Bond Claims and the Indenture Trustee’s claim for fees and expenses. Please refer to the Liquidation Analysis for estimated recoveries for those Bond Claims.

Committee,³¹ (g) the plaintiffs in the Securities Litigation³² through their counsel, and (h) Paul Capital Advisors, L.L.C. (“Paul Capital”) through its counsel.

Although the mediation remains ongoing, it has resulted in the Mediated Settlement, the material terms of which are described below and in Article II.C of this Disclosure Statement. Additionally, on April 17, 2023, in connection with further mediation, the Debtors, the Bondholder Committee, and LBM, among others, entered into the *Stipulation Regarding Mediated Resolution in Connection With Debtors’ Motion for Entry of an Order Approving Amendments to Consulting Agreement with Jeffrey S. Stein and Independent Director Agreement with Anthony R. Horton [D.I. 1392]* (the “Compensation Motion Stipulation”), which, among other things, resolves certain matters in connection with the Compensation Motion, as described in Article II.B.4 of this Disclosure Statement, and provides that the Debtors may not agree to any settlement of potential Estate Claims or Causes of Action with the Beneficient Parties without the consent of the Creditor Proponents.

1. Framework of the Second Amended Plan

The Second Amended Plan provides that the Debtors will be liquidated and two liquidating trusts will be created: (i) the Wind Down Trust and (ii) the Litigation Trust. The Wind Down Trust will take all necessary steps to wind down the business affairs of the Debtors and liquidate the Wind Down Trust Assets, which include the Debtors’ equity interests in the Policy Portfolio (i.e., the Policy Portfolio Equity Interests), Beneficient and FOXO, with a view toward maximizing the value of such assets for the benefit of creditors and promptly distributing such liquidation proceeds to creditors. The trustee of the Wind Down Trust will be Elizabeth C. Freeman (or an affiliate of Elizabeth C. Freeman). The Wind Down Trust will issue trust interests (the New WDT Interests) to Holders of Claims and Interests that are not paid in full in cash on the Effective Date of the Second Amended Plan. Distributions resulting from the monetization of the Policy Portfolio Equity Interests and the Debtors’ interests in Beneficient and FOXO will be distributed to holders of New WDT Interests pursuant to the priority of payment waterfall set forth in Article IV.H of the Second Amended Plan.

The Litigation Trust will receive all non-released litigation assets of the Debtors as well as the Debtors’ interests in the D&O Liability Insurance Policies. The trustee for the Litigation Trust (i.e., the Litigation Trustee) will have the sole authority to make decisions and take action with respect to the Initial Litigation Trust Assets, the Retained Causes of Action, and the Litigation Trust Reconciliation Claims, and shall have the duty to maximize the value of the assets of the Litigation Trust in accordance with the Litigation Trust Agreement. The Litigation Trustee will be Michael I. Goldberg or such other independent, third-party fiduciary with no affiliation with any Bondholder or member of the Bondholder Committee. All proceeds of the Litigation Trust will be distributed to the Wind Down Trust, as the beneficiary of the Litigation Trust, for further distribution to the holders of New WDT Interests pursuant to the priority of payment waterfall set forth in Article VI.C of the Second Amended Plan.

³¹ LBM and the Ad Hoc Broker/Dealer Committee are described further in Article VI.B of this Disclosure Statement.

³² The Securities Litigation is described further in Article V.A.2 of this Disclosure Statement.

The Second Amended Plan is described in more detail in a question and answer format in Article II.C of this Disclosure Statement.

2. LBM Settlement

The Debtors understand that, pursuant to certain powers of attorney, certain trusts (the Seller Trusts and Custody Trusts described in further detail in Article VI.B.3 of this Disclosure Statement) that hold Seller Trust L Bonds and equity interests in GWGH, designated LBM as agent with respect to claims (and related litigation) relating to the Seller Trust L Bonds. The powers of attorney also grant LBM authority to act for the Custody Trusts and Seller Trusts in any bankruptcy proceedings affecting the property of such trusts. However, the Debtors understand that LBM has no authority or control over any equity interests held by the Seller Trusts. LBM is a special purpose entity formed under Delaware law and is represented by Okin Adams Bartlett Curry LLP, as legal counsel, and Gordian Group, as investment banker.

(a) *Description of the LBM Settlement*

Pursuant to the Mediation Agreement, and subject to the terms set forth in Article IV.I of the Second Amended Plan, LBM has agreed to subordinate 15% of its LBM L Bond Claims to all other existing Allowed Bond Claims in exchange for the full Allowance of the LBM L Bond Claims and the release of any and all civil claims held by the Debtors' Estates against the LBM Released Parties (the "LBM Settlement"). So long as LBM does not withdraw from the LBM Settlement, the 15% subordinated portion of the LBM L Bond Claims would constitute LBM Subordinated Claims (if LBM does withdraw, then the LBM Subordinated Claims would be the portion of the LBM L Bond Claims, if any, that is subordinated pursuant to a Final Order of the Bankruptcy Court). In exchange for the subordination of the LBM Subordinated Claims, the LBM L Bond Claims will be Allowed in the amount of \$377,516,519.13, and the LBM Released Parties will receive a full release of any and all civil claims held by the Debtors' Estates against them. The "LBM Released Parties" means, collectively, and in each case in their respective capacities as such: (a) LBM; (b) LBM's managers, employees, agents, attorneys and representatives solely in such capacity and solely for actions taken in such capacity that are related to the acquisition, holding, or disposition of any Seller Trust L Bonds for which LBM acts as agent including the LBM L Bond Claims; (c) the trusts identified in the definition of LBM L Bond Claims, the trustees and trust advisors of such trusts, current officers, directors, and advisors of such trusts, each solely in such capacity and solely for actions taken on behalf of such trusts; and (d) Richard Schmidt, the restructuring manager of LBM, and his professionals; *provided, however*, that any release of the LBM Released Claims are to be narrowly construed, and to the extent any LBM Released Parties serve or have served in multiple capacities, such releases do not extend beyond capacities as described above.

Notwithstanding the foregoing, in the event that the Debtors reach a settlement with the Beneficient Parties (as defined below), LBM may withdraw from the LBM Settlement by filing a written notice with the Bankruptcy Court within three Business Days of the filing of a Settlement Motion (as defined below). In the event that LBM withdraws from the LBM Settlement, (a) all agreements memorialized in the Second Amended Plan with respect to the LBM Settlement shall be deemed withdrawn, including, but not limited to, all subordination agreements and all Claim allowances; (b) all claims, offsets, credits, objections and challenges of any kind to claims

proposed to be settled pursuant to the Second Amended Plan are reinstated in their entirety and shall be transferred to the Litigation Trust on the Effective Date as Litigation Trust Reconciliation Claims; and (c) the LBM L Bond Claims will be deemed Disputed Class 3 Claims without further action, filing, or other request by the Debtors or the Bondholder Committee until the Claim Objection Bar Date at which time the LBM L Bond Claims shall be Allowed; *provided*, that such LBM L Bond Claims shall be considered Allowed only if and to the extent that no objection or other challenge in respect of the LBM L Bond Claims has been Filed on or prior to the Claim Objection Bar Date or such timely objection or other challenge has been Filed and the Claim thereafter has been Allowed by a Final Order. In any case, the LBM L Bond Claims shall be fully Allowed for voting purposes, and LBM agrees to and shall support and shall be deemed to accept the Second Amended Plan on account of the LBM L Bond Claims and be a Creditor Proponent consistent with the Mediation Agreement (it being understood that any settlement with Beneficient shall be set forth in an order approving any such settlement under Bankruptcy Rule 9019 and that LBM's only rights with respect to a settlement with Beneficient are (i) withdrawing from the settlement set forth in Article IV.I of the Second Amended Plan and/or (ii) objecting to such settlement with Beneficient).

The full terms of the LBM Settlement are set forth in Article IV.I of the Second Amended Plan.

(b) Factors in Support of the LBM Settlement

When considering a compromise settlement, the Fifth Circuit requires the Bankruptcy Court to consider: “(1) the probability of success in the litigation, with due consideration for the uncertainty in fact and law, (2) the complexity and likely duration of the litigation and any attendance expense, inconvenience, and delay, and (3) all other factors bearing on the wisdom of the compromise” including the “paramount interest of creditors with proper deference to their reasonable views” and whether the settlement is the product of arms'-length negotiation. *In re Foster Mortg. Corp.*, 68 F.3d 914, 918 (5th Cir. 1995) (citations omitted).

The investigation by the Investigations Committee and the Bondholder Committee included a detailed review and analysis of potential claims and defenses related to the LBM L Bond Claims, which included, among other things, an investigation and analysis with respect to (i) the creation and structure of the Seller Trusts, (ii) the issuance of the Seller Trust L Bonds, (iii) the terms governing the Seller Trust L Bonds, (iv) amendments to documents governing the treatment and repayment of the Seller Trust L Bonds, (v) documentary evidence and witness testimony with respect to the foregoing, and (vi) public disclosures made with respect to the foregoing.

Based on this investigation, the Investigations Committee and the Bondholder Committee determined that potentially viable claims exist to subordinate and/or recharacterize the LBM L Bond Claims. A claim for equitable subordination generally would be premised on, among other things, (i) the actions taken by Trust Advisors for the Seller Trusts, (ii) the issuance of the Seller Trust L Bonds as a form of currency for certain transactions that may themselves be challenged, and (iii) public disclosures in connection with the Seller Trust L Bonds concerning the Debtors' indebtedness and ability to continue to issue additional L Bonds. A claim for mandatory

subordination or recharacterization of the LBM L Bond Claims would be based on arguments that, in certain circumstances, the Seller Trust L Bonds could be repaid in equity of GWG.

With respect to the first *Foster Mortgage* factor, in reaching the LBM Settlement, the Investigations Committee and the Bondholder Committee weighed the strengths and weaknesses of the arguments and considered the probabilities of potential outcomes. With respect to equitable subordination of the LBM L Bond Claims, a challenging party may be required to prove, among other things, that the Seller Trusts—as the holders of the Seller Trust L Bonds—engaged in inequitable conduct. While the Investigations Committee and the Bondholder Committee have uncovered evidence of potentially inequitable conduct, LBM may argue that proving inequitable conduct directly by the Seller Trusts themselves—as opposed to by former directors or officers of the Debtors—is required, which could present a challenge to succeeding on a claim for equitable subordination.

With respect to mandatory subordination and recharacterization, the Investigations Committee's and the Bondholder Committee's analysis of the relevant documents supports the argument that, in certain circumstances, the Seller Trust L Bonds could be payable in equity of GWG. Whether the applicable case law supports mandatory subordination or recharacterization, however, is not certain and litigation of the issue could result in a determination that mandatory subordination or recharacterization is improper. In opposing recharacterization and mandatory subordination, LBM may argue, among other things, that (i) the Seller Trust L Bonds were issued under the same indenture as all other L Bonds, (ii) the Debtors historically paid cash interest on the Seller Trust L Bonds, consistent with their regular practice, and (iii) under the current circumstances, the Debtors do not have the right to repay the Seller Trust L Bonds in GWG equity.

With respect to the second *Foster Mortgage* factor, the Investigations Committee and the Bondholder Committee considered the cost of litigating these claims and the necessary time and duration for doing so. The nature and circumstances of the subordination and recharacterization claims which could be asserted would require a fact intensive and complex litigation, which would be at significant expense to the Debtors' estates. Absent a settlement, it is likely that the Debtors and/or the Bondholder Committee would have been required to object to the LBM L Bond Claims prior to the Confirmation Hearing, potentially resulting in expedited, expensive and uncertain litigation over, among other things, temporary allowance or estimation of the LBM L Bond Claims, separate classification of the LBM L Bond Claims, and/or designation of LBM's votes. The LBM Settlement avoids this costly exercise with an uncertain outcome.

Finally, with respect to the third *Foster Mortgage* factor, the LBM Settlement was the product of hard-fought, arms'-length negotiation in the context of mediation. The LBM Settlement provides for the subordination of 15% of the LBM L Bond Claims (if LBM does not withdraw from the LBM Settlement) and, in all circumstances, ensures that LBM, which controls the vote of approximately 23% of Class 3 (Bond Claims), will vote to accept the Second Amended Plan on account of the Seller Trust L Bond Claims, which significantly enhances the likelihood that Class 3 will vote to accept the Second Amended Plan by the requisite bankruptcy majorities and better positions the Debtors to emerge from chapter 11. Importantly, pursuant to the LBM Settlement, LBM must vote to accept the Second Amended Plan even if LBM determines to withdraw from

the LBM Settlement and, in such event, no distributions will be made on account of LBM L Bond Claims and the claims and challenges in respect of the LBM L Bond Claims will be preserved for pursuit by the Litigation Trust and avoid the need to litigate with LBM prior to Confirmation. As such, the Debtors and the Bondholder Committee believe that the LBM Settlement is in the best interests of creditors.

In sum, given (i) the uncertain outcome of litigation, which may have resulted in 0% of the Seller Trust L Bonds being subordinated to the recoveries of all other L Bondholders, (ii) the significant time and expense that would be associated with uncertain litigation in respect of the Seller Trust L Bonds, (iii) the arms'-length nature of the compromise achieved in the context of mediation, (iv) LBM's obligation to vote in favor of the Second Amended Plan in all circumstances, and (v) the preservation of the right of the Litigation Trust to pursue any and all claims and challenges in respect of the LBM L Bond Claims in the event LBM withdraws from the LBM Settlement, the Debtors and the Bondholder Committee determined that entering into the LBM Settlement was in the best interests of the Debtors' estates and believe that the *Foster Mortgage* factors are met.

3. Agreements Related to a Potential Settlement with Beneficient

As discussed further herein, the Debtors' Investigations Committee and the Bondholder Committee have investigated available Claims and Causes of Action related to, among other things, certain prepetition transactions between the Company and Beneficient that are described further in Article II.A.4 and Article IV.A.2.b of this Disclosure Statement. As described above, the Investigations Committee believes that the Company holds colorable claims against Beneficient and various Entities affiliated with Beneficient arising under the Bankruptcy Code or applicable state law for, among other things and without limitation, constructive and actual fraudulent transfers, breaches of fiduciary duties, and aiding and abetting such breaches of fiduciary duty. Discussions among the Debtors (through the Investigations Committee), Beneficient, and various Entities affiliated with Beneficient, including Beneficient's officers and directors (collectively with Beneficient, the "Beneficient Parties") remain ongoing. In accordance with the Mediated Settlement and the Compensation Motion Stipulation, if the Debtors, with the consent of the Creditor Proponents, reach a settlement with Beneficient or any of the Beneficient Parties prior to the Confirmation Hearing, the Debtors will file a separate motion pursuant to Bankruptcy Rule 9019 to seek Bankruptcy Court approval of such settlement (a "Settlement Motion"). Such a Settlement Motion, in order to be heard at the Confirmation Hearing, must be filed with at least 21 days' notice unless (a) the Bankruptcy Court, on its own motion, orders otherwise, or (b) the Debtors and the Creditor Proponents agree otherwise.³³ Additionally, pursuant to the Compensation Motion Stipulation, the Debtors have agreed to not enter into any settlement

³³ The Bondholder Committee asserts that it has identified various viable and valuable claims and causes of action that are described in detail in the Bondholder Committee's Standing Motion (as discussed in Article VI.H.3 of this Disclosure Statement). LBM has received limited information related to the investigations and conclusions of the Investigations Committee and the Bondholder Committee as to the existence of colorable claims. As such, LBM neither joins with nor adopts the positions of any of the Debtors, the Investigations Committee, or the Bondholder Committee. LBM expresses no opinion regarding the merits of any alleged claims or their potential value to Bondholders.

of potential Estate Claims or Causes of Action with the Beneficient Parties without the consent of the Creditor Proponents.

The Debtors have not as of the date hereof reached a settlement with any of the Beneficient Parties. It is possible that the Debtors will not reach any settlement with the Beneficient Parties before the Confirmation Hearing. If the Debtors, with the consent of the Creditor Proponents, reach a settlement with any of the Beneficient Parties, the Debtors will file a Settlement Motion and, if approved, the terms of such settlement will be implemented without any resolicitation of the Second Amended Plan. In connection with a Settlement Motion, if any, the Debtors would seek Bankruptcy Court approval to grant releases by the Debtors to the settling parties of settled Claims and Causes of Action in exchange for agreed upon consideration from such settling parties. In any Settlement Motion, the Debtors would describe the terms of the proposed settlement, the parties either giving or receiving releases, the scope of such releases, and explain why the proposed settlement is in the best interests of the Debtors' Estates in lieu of litigating the claims that are proposed to be settled. The provisions of the Second Amended Plan expressly recognize the effectiveness of any releases granted pursuant to a separate order of the Bankruptcy Court entered on or before the Effective Date. Accordingly, the Debtors do not intend to amend the Second Amended Plan to include additional parties as "Released Parties" under the Second Amended Plan, meaning that only those Entities that are party to a settlement agreement would grant releases thereunder. Therefore, the Second Amended Plan can be confirmed and the Effective Date can occur whether or not a settlement is reached with any of the Beneficient Parties.

The Debtors have agreed pursuant to the Mediation Agreement that they will not provide any consent to the Avalon Business Combination without Bankruptcy Court approval, with the understanding that such approval may be sought in conjunction with a Settlement Motion or on its own if there is no settlement.

4. Resolution of Compensation Motion

As further described in Article VI.J of this Disclosure Statement, the Debtors filed the Compensation Motion seeking to increase the compensation for Messrs. Stein and Horton on account of the expansion of their responsibilities. Pursuant to the Mediation Agreement, the Debtors agreed to adjourn the hearing on the Compensation Motion to the Confirmation Hearing.

Following further mediation, the Debtors, the Bondholder Committee, and LBM, among other parties, entered into the Compensation Stipulation, which included a mediated resolution of the Compensation Motion. Accordingly, pursuant to Article IV.W of the Second Amended Plan, on the Effective Date, the Debtors will pay: (1) to Jeffrey S. Stein, a modified "Success Bonus" pursuant to Mr. Stein's Consulting Agreement (as defined in the CRO and Directors Order) approved pursuant to the CRO and Directors Order, which shall be (a) \$1,830,000 in Cash, and (b) 40,000 common units of Beneficient owned by the Debtors, in each case to be paid on the Effective Date of this Plan; *provided, however*, that if Beneficient has consummated the Avalon Business Combination prior to the Effective Date, Mr. Stein shall be entitled to receive 50,000 shares of Class A common stock, par value \$0.001 per share, of New Beneficient owned by the Debtors; and (2) to Anthony R. Horton, additional compensation to the compensation payable in accordance with Mr. Horton's engagement letter in the amount of \$120,000 in Cash.

5. The Indenture Trustee's Fees and Expenses

Pursuant to the Indenture, GWGH and GWG Life are obligated to pay the reasonable compensation, disbursements, advances and expenses of the Indenture Trustee, its agents and counsel (as defined in the Second Amended Plan, the Indenture Fee and Expense Claim), and the Indenture Trustee's right to payment of the Indenture Fee and Expense Claim has first priority with respect to distributions of the assets of GWGH and GWG Life. Pursuant to the Mediation Agreement, the Debtors and Creditor Proponents will seek to reach an agreement with the Indenture Trustee on the amount of the Indenture Fee and Expense Claim, and to the extent they reach an agreement on part or all of the Indenture Fee and Expense Claim, such Indenture Fee and Expense Claim will be paid in cash on the Effective Date to the extent of available Portfolio Proceeds. If an agreement cannot be reached on the amount of the Indenture Fee and Expense Claim, the parties will submit the dispute for further mediation to the Mediator and to the extent agreement cannot be reached after such further mediation, the Debtors may submit the dispute to the Bankruptcy Court. Pursuant to the Second Amended Plan, the Indenture Trustee, an account of the Indenture Fees and Expense Claim, will look first to the Portfolio Proceeds Amount for payment and, to the extent not satisfied thereby, the Indenture Trustee will receive New Series A1 WDT Interests having senior priority over the other New Series A1 WDT Interests.

6. Resolution of the Ad Hoc Broker/Dealer Committee's Objection to the Disclosure Statement and Potential Objection to the Second Amended Plan

As discussed further in Article VI.B.4 of this Disclosure Statement, an ad hoc committee of certain Broker Dealers who sold Public L Bonds (i.e., the Ad Hoc Broker/Dealer Committee) was formed in connection with these Chapter 11 Cases. The Ad Hoc Broker/Dealer Committee has actively engaged with the Debtors in the Debtors' efforts to reach a value maximizing and consensual chapter 11 plan, including participating in several mediation sessions and working with the Debtors on developing certain elements of the Second Amended Plan. When the Debtors initially filed the Second Amended Plan, the Ad Hoc Broker/Dealer Committee did not agree with certain provisions contained therein, and filed the *Objection of the Ad Hoc Committee of Broker/Dealers to (A) the Adequacy of the Disclosure Statement for the Debtors' Second Amended Joint Chapter 11 Plan, Submitted by the Debtors, the Bondholder Committee, and L Bond Management, LLC as Co-Proponents, and (B) the Solicitation Procedures in Connection Therewith* (the "AHC Objection").

Following the Ad Hoc Broker/Dealer Committee's filing of the AHC Objection, the Debtors continued to engage with the Ad Hoc Broker/Dealer Committee regarding the Second Amended Plan and related disclosure statement. On April 17, 2023, the Debtors, the Bondholder Committee, and the Ad Hoc Broker/Dealer Committee reached an agreement under the Second Amended Plan that fully resolves any claims that the Ad Hoc Broker/Dealer Committee could assert for making a substantial contribution to these Chapter 11 Cases, and in connection therewith, the Debtors have agreed to pay the actual and reasonable fees and expenses of the Ad Hoc Broker/Dealer Committee not to exceed \$1,000,000 on the Effective Date of the Second Amended Plan.

7. Additional Mediated Settlement Terms

Additionally, pursuant to the Mediation Agreement, the Creditor Proponents have the right, acting separately (the “Proponents Consent Right”) to review and consent to the form and substance of the Second Amended Plan, this Disclosure Statement and the forthcoming Plan Supplement, including trust agreements and other applicable documents, to ensure that it is consistent with, and can effectuate the settlement memorialized in the Mediation Agreement, and to address issues not explicitly covered by the Mediation Agreement but that are customary and required for a chapter 11 plan. Pursuant to Article I.G of the Second Amended Plan, following the filing of the Second Amended Plan, in the event the Debtors and the Creditor Proponents cannot agree to the form and substance of any documents in connection with the Second Amended Plan (and such document is subject to the Proponents’ Consent Rights or other consent rights under the Second Amended Plan) or any decision which requires the consent of the Creditor Proponents, by the applicable deadline for filing such document thereunder, any such dispute shall be submitted to the Mediator. To the extent of any remaining disputes following such mediation, then, pending final resolution thereof, any of the Debtors and the Creditor Proponents may file its own version of any such disputed document by the applicable deadline therefor. In such event: (1) the filing of competing versions of any such disputed document shall be deemed to have satisfied any such filing deadline thereunder, (ii) the Debtors and Creditor Proponents shall continue as co-proponents of the Second Amended Plan for all purposes, and (ii) the final form of any such disputed document will be subsequently resolved through either mediation with the Mediator or by order of the Bankruptcy Court.

The Mediation Agreement also includes certain agreements that are described in other sections of this Disclosure Statement as follows:

- the Creditor Proponents’ agreement not to object to certain extensions of the Debtors’ exclusive period to solicit a chapter 11 plan through the earlier of the Confirmation Hearing and June 23, 2023 is described in Article VI.D; and
- the Bondholder Committee’s agreement to adjourn the hearing on the Bondholder Committee’s Standing Motion until the earlier of the Confirmation Hearing and June 23, 2023 (or the first available date on the Bankruptcy Court’s calendar after June 23, 2023) is described in Article VI.H.3.

Additionally, the Creditor Proponents’ agreed not to object to a mid-range valuation for the Debtors’ assets, solely for purposes of the Second Amended Plan, if such mid-range valuation does not exceed \$1 billion, while also reserving their rights to object to a mid-range valuation of the Debtors’ assets that is greater than \$1 billion.

C. Summary of the Second Amended Plan

Key aspects of the Second Amended Plan, in addition to those described in the above Article II.B, are described in the following chart in a question and answer format.

Question	Answer
<p><i>Will the Debtors continue to operate after they have emerged from bankruptcy?</i></p>	<p>No. The Debtors will <i>not</i> continue to operate as going concerns following the Effective Date, and will instead be liquidated at such time (or a later time, if agreed to by the Debtors and Creditor Proponents to promote tax efficiencies).</p> <p>Pursuant to the Second Amended Plan, two liquidating trusts will be created. These liquidating trusts are referred to as the Wind Down Trust and the Litigation Trust, and all of the Debtors' assets will be transferred to one of those two liquidating trusts. As described below, a Portfolio Co. will also be created to hold the Policy Portfolio.</p> <p><i>For more information, see Article IV.A and E of the Second Amended Plan.</i></p>
THE WIND DOWN TRUST	
<p><i>What will the purpose of the Wind Down Trust be and what assets will be transferred to the Wind Down Trust?</i></p>	<p>The Wind Down Trust will be established for the purpose of liquidating the Wind Down Trust Assets, with a view towards maximizing the value of such assets for the benefit of New WDT Interest holders and distributing such liquidation proceeds to New WDT Interest holders.</p> <p>The Wind Down Trust Assets include the Policy Portfolio Equity Interests, the Debtors' interests in Beneficient and FOXO, all reversionary and beneficial interests in the Litigation Trust and any remaining Assets of the Debtors, other than the Initial Litigation Trust Assets. The Wind Down Trust will be initially funded with the Wind Down Amount, which is an amount that will be agreed to by the Debtors and the Creditor Proponents, subject to the Proponents' Consent Right, and will be set forth in the Plan Supplement.³⁴</p> <p><i>For more information, see Article IV.A of the Second Amended Plan.</i></p>
<p><i>What is role of the Wind Down Trustee?</i></p>	<p>The Wind Down Trustee will have the sole authority to make decisions and take action with respect to the Wind Down Trust in accordance with the Second Amended Plan and the Wind Down Trust Agreement. The Wind Down Trustee, on behalf of the Wind Down Trust, will have discretion to enter into, consummate, settle, or otherwise resolve any transaction or dispute with respect to each of the Wind Down Trust Assets that have an economic value of less than \$5 million (in the Wind Down Trustee's good faith determination) as of the date of the consummation, settlement, or resolution of such transaction or dispute. The Wind Down Trustee will submit all other matters to the Bankruptcy Court for approval after notice and an opportunity for a hearing.</p>

³⁴ Pursuant to the Mediation Agreement, if the Debtors and Creditor Proponents are unable to agree on the Wind Down Budget, then the Debtors will seek approval from the Bankruptcy Court of the Wind Down Budget.

	<p>The Wind Down Trustee will have the sole authority with respect to claims administration, including the sole authority to File, withdraw, or litigate to judgment objections to Claims or Interests, other than with respect to the Litigation Trust Reconciliation Claims, which are Claims or Interests held or filed by any defendant in any litigation initiated by the Litigation Trust or, in consultation with the Wind Down Trustee, Entity against whom the Litigation Trustee expects to initiate litigation, any Broker Dealer or Holders of LBM L Bond Claims, in the event LBM withdraws from the LBM Settlement.</p> <p>The Wind Down Trustee will be Elizabeth C. Freeman or any Affiliate of Elizabeth C. Freeman that is identified in the Plan Supplement.</p> <p><i>For more information, see Article IV.A and Article VII.B of the Second Amended Plan.</i></p>
<p><i>What does the Second Amended Plan provide with respect to selling the interests in Ben and FOXO?</i></p>	<p>All determinations regarding the monetization of the Wind Down Trust’s interests in Beneficient and FOXO will be subject to the reasonable business judgment of the Wind Down Trustee, subject to compliance with any applicable lock-up agreement or securities law requirements and subject to the requirement that the Wind Down Trustee seek and obtain Bankruptcy Court approval of any transaction with an economic value of \$5 million or more, as set forth in the Second Amended Plan.</p> <p><i>For more information, see Article IV.A.3 of the Second Amended Plan.</i></p>
<p><i>What will happen with the Policy Portfolio?</i></p>	<p>The Company will establish a new entity, pursuant to the Vida DIP Financing Facility and Vida Exit Financing Facility, referred to as “<u>Portfolio Co.</u>” The DLP Entities will transfer the Policy Portfolio to Portfolio Co. The equity interests in this new entity (the “<u>Policy Portfolio Equity Interests</u>”) will be issued and transferred to the Wind Down Trust.</p> <p><i>For more information, see Article IV.C of the Second Amended Plan.</i></p>
THE LITIGATION TRUST	
<p><i>What will the purpose of the Litigation Trust be and what assets will be transferred to the Litigation Trust?</i></p>	<p>The Litigation Trust will be established on the Effective Date to retain and hold all Retained Causes of Action. The proceeds of the Retained Causes of Action will be distributed to the Wind Down Trust for ultimate distribution in accordance with the waterfall described below and set forth in <u>Article VI.C</u> of the Second Amended Plan. Retained Causes of Action include all Avoidance Actions, all Causes of Action set forth on a schedule in the Plan Supplement (the form and substance of which being subject to the Proponents’ Consent Right), and any other Causes of Action</p>

	<p>belonging to the Debtors or their Estates that are not explicitly released pursuant to the Second Amended Plan or other Final Order. The potential value of the Retained Causes of Action is described in further detail in <u>Article II.A.4</u> of this Disclosure Statement.</p> <p>A non-exclusive list of the Retained Causes of Action will be Filed with the Plan Supplement. The Debtors' inclusion or failure to include any Retained Cause of Action in the Second Amended Plan, this Disclosure Statement, or the Plan Supplement will not be deemed an admission, denial or waiver of any Retained Cause of Action that the Debtors or Estates may hold against any Entity.</p> <p>The Initial Litigation Trust Assets will be vested in the Litigation Trust on the Effective Date. The Initial Litigation Trust Assets include the following assets: (a) the Initial Litigation Trust Funding Amount (an amount equal to \$3 million in Cash); (b) the Retained Causes of Action; (c) the Debtors' interests in the D&O Liability Insurance Policies that provide coverage prior to April 20, 2022; and (d) the Debtors' interests in the proceeds of such policies and the Debtors' entitlements and rights to payments thereunder.</p> <p><i>For more information, see Article IV.D of the Second Amended Plan.</i></p>
<p><i>What is the role of the Litigation Trustee?</i></p>	<p>The Litigation Trustee shall have the sole authority to make decisions and take action with respect to the Initial Litigation Trust Assets, the Retained Causes of Action, and the Litigation Trust Reconciliation Claims, and shall have a duty to maximize the value of the assets of the Litigation Trust in accordance with the Litigation Trust Agreement. The Litigation Trustee shall confer with the Wind Down Trustee with respect to the commencement of any litigation in respect of such assets, provided that the ultimate decision with respect to whether to commence any litigation shall be in the sole discretion of the Litigation Trustee. For the avoidance of doubt, in exercising such sole discretion, the Litigation Trustee shall consider and may take such actions in connection with the exercise of such sole discretion that promote the greatest recovery to the holders of the New WDT Interests. The Litigation Trustee shall seek Bankruptcy Court approval, after notice and an opportunity for a hearing, of (1) any settlements with respect to the Retained Causes of Action, and (2) any other transaction with respect to any assets of the Litigation Trust, in each case, that has an economic value of \$5 million or more (in the Litigation Trustee's good faith determination) as of the date of such transaction.</p> <p>The Litigation Trustee will be Michael I. Goldberg, or such other independent, third-party fiduciary selected by the Bondholder Committee and identified in the Plan Supplement. The Litigation</p>

	<p>Trustee will not have any affiliation with any Bondholder Committee member and will not own any Public L Bonds, New WDT Interests or other Interests in or Securities issued by the Debtors.</p> <p><i>For more information, see Article IV.D and Article IV.P of the Second Amended Plan.</i></p>
INTERESTS IN THE LIQUIDATING TRUSTS	
<p><i>What securities will Holders of Allowed Bond Claims receive?</i></p>	<p>Bondholders will receive New Series A1 WDT Interests, which will be entitled to Cash distributions pursuant to the priority of payment waterfalls set forth in <u>Article IV.G</u> and <u>Article VI.C</u> of the Second Amended Plan.</p> <p>With respect to Holders of LBM L Bond Claims, such Holders will receive New Series A2 WDT Interests with respect to the LBM Subordinated Claim and will receive New Series A1 WDT Interests with respect to the remaining portion of their LBM L Bond Claims.</p> <p><i>For more information regarding the New Series A1 WDT Interests and the New Series A2 WDT Interests, see Article III.B.3, Article IV.E.2 and Article IV.G of the Second Amended Plan.</i></p>
<p><i>What securities will Holders of certain other Allowed Claims (other than Bond Claims) or Interests receive?</i></p>	<p>The following Holders of Allowed Claims or Interests will receive beneficial interests under the Second Amended Plan:</p> <ul style="list-style-type: none"> • Class 4(a) – General Unsecured Claims – will receive New Series B WDT Interests. • Class 8 – Series 1 Preferred Interests – will receive New Series C WDT Interests. • Class 9 – Series 2 Preferred Interests – will receive New Series D WDT Interests. • Class 10 – Common Stock in GWGH – will receive New Series E WDT Interests. <p><i>For more information regarding each series of the New WDT Interests, see Article III.B, Article IV.E.2 and Article IV.G of the Second Amended Plan.</i></p>
DISTRIBUTIONS FROM THE LIQUIDATING TRUSTS	
<p><i>How will proceeds of the Vida DIP Financing Facility and the Vida Exit Financing Facility be used?</i></p>	<p>The Vida DIP Financing Facility and the Vida Exit Financing Facility will fund the Portfolio Proceeds Amount, the Initial Litigation Trust Funding Amount, and the Wind Down Budget. Each of these is described further below:</p> <ul style="list-style-type: none"> • The Portfolio Proceeds Amount is an amount consisting of the expected net Cash proceeds from the Vida DIP Financing Facility, <i>less</i> the sum of the three following amounts: <ul style="list-style-type: none"> ○ The Estimated Effective Date Shortfall Amount, which is an amount, if any, necessary to satisfy Allowed Claims that are required to be paid in full in Cash on the Effective Date less the amount of Cash

	<p>the Debtors expect to have available for such purpose (excluding net Cash proceeds from the Vida DIP Financing Facility), in each case, as estimated by the Debtors (in consultation with the Creditor Proponents);</p> <ul style="list-style-type: none"> ○ The Initial Litigation Trust Funding Amount, which is \$3 million in Cash; and ○ The Wind Down Amount, the amount of which will be set forth in the Plan Supplement. <p>The Portfolio Proceeds Amount, if any, will be distributed to Holders of Allowed Bond Claims (other than the LBM Subordinated Claims) in accordance with the Second Amended Plan on the Effective Date.</p> <p>The proceeds from the Vida Exit Financing Facility shall be used to refinance the Vida DIP Financing Facility.</p> <p><i>For more information, see Article III.B.3 and Article IV.E.1 of the Second Amended Plan.</i></p>
<p><i>What is the priority of distributions to holders of New WDT Interests with respect to Net Cash Proceeds of the Wind Down Trust Assets?</i></p>	<p>The distribution of any proceeds from the Wind Down Trust Assets is described in <u>Article VII.C</u> of this Disclosure Statement and will be made in the following order of priority among Holders of Claims and Interests:</p> <ul style="list-style-type: none"> • <i>first</i>, to Indenture Fee and Expense Claims; • <i>second</i>, to the prepetition amount of Allowed Bondholder Claims (other than the LBM Subordinated Claim); • <i>third</i>, to the prepetition amount of the LBM Subordinated Claim; • <i>fourth</i>, to all Allowed Bondholder Claims up to the amount of interest accrued under the New WDT Documents from April 20, 2022, at a rate of 9% per annum; • <i>fifth</i>, to the prepetition amounts of Allowed General Unsecured Claims; • <i>sixth</i>, to postpetition interest on Allowed General Unsecured Claims calculated at the Federal Judgment Rate • <i>seventh</i>, to Existing Preferred Interests holders on a <i>pari passu</i> basis; • <i>eighth</i>, to common stock holders. <p><i>For more information, see Article IV.H of the Second Amended Plan.</i></p>
<p><i>What is the priority of distributions to holders of New WDT Interests with respect to net proceed realized by the Litigation Trust?</i></p>	<p>The distribution of any proceeds from the Litigation Trust assets is described in <u>Article VII.C</u> of this Disclosure Statement and will be made in the following order of priority among Holders of Claims and Interests:</p> <ul style="list-style-type: none"> • <i>first</i>, to Indenture Diminution Claims;

	<ul style="list-style-type: none"> • <i>second, pro rata</i> to holders of Allowed Bondholder Claims (subject to the intercreditor arrangements established in the waterfall with respect to Wind Down Trust Assets) and Allowed General Unsecured Claims, up to the aggregate outstanding prepetition amounts of such Claims; • <i>third, pro rata</i> to holders of Allowed Bondholder Claims (subject to the intercreditor arrangements established in the waterfall with respect to Wind Down Trust Assets) and Allowed General Unsecured Claims, with respect to interest that accrues under the Second Amended Plan; • <i>fourth</i>, to Existing Preferred Interests holders on a <i>pari passu</i> basis; • <i>fifth</i>, to common stock holders. <p>The Indenture Diminution Claims are any Claims of the Indenture Trustee asserted on account of the decrease in the value of the Indenture Trustee’s interest in the collateral securing the obligations under the Indenture, arising from the “Adequate Protection Liens” granted to the Indenture Trustee pursuant to the Chapford Final DIP Order and the Final Vida Order. On the Effective Date, the Indenture Diminution Claims shall be deemed an Allowed Administrative Claim in the amount as agreed by the Debtors, the Indenture Trustee, and the Creditor Proponents, or as determined by the Court, in the event such parties are unable to reach an agreement as to the amount during further mediation.</p> <p><i>For more information, see Article VI.C of the Second Amended Plan.</i></p>
ADDITIONAL PROVISIONS	
<p><i>Will the New WDT Interests issued in connection with the reorganization be freely transferable?</i></p>	<p>Not initially. The Second Amended Plan will provide that the New WDT Interests are not transferable except by will, intestacy or operation of law. The Wind Down Trustee will be permitted to determine in its sole discretion to take such actions that are necessary or reasonably advisable (including, without limitation, completing a registration under the Securities Exchange Act) to modify or remove any contractual restrictions on transferability of the New WDT Interests, with any such determination by the Wind Down Trustee, and all costs associated therewith, to be deemed a determination with respect to the monetization of the Wind Down Trust Assets subject to Bankruptcy Court approval to the extent provided pursuant to <u>Article IV.A.3</u> of the Second Amended Plan and to be evaluated solely under a reasonable business judgment standard.</p> <p>Even if the New WDT Interests are made transferrable, the New WDT Interests will not be listed on any national securities exchange and no assurance can be given that an active trading market for the New WDT Interests will develop. In addition, in such a case the</p>

	<p>Wind Down Trust will not engage the services of a market maker or otherwise facilitate the development of an active trading market.</p> <p><i>For more information, see Article VIII.B.6 of this Disclosure Statement and Article IV.I of the Second Amended Plan.</i></p>
<p><i>Does the Second Amended Plan contain releases?</i></p>	<p>Yes. The Second Amended Plan contains releases by the Debtors, the Wind Down Debtors or their Estates of claims that arose on or before the Effective Date. Additionally, certain Exculpated Parties are released from Exculpated Claims, which are certain claims relating to an act or omission from the Petition Date to the Effective Date in connection with these Chapter 11 Cases.</p> <p>Importantly, other than to the extent provided in the Debtor release or the exculpation provisions, the Second Amended Plan does not include third party releases.</p> <p><i>For more information, see Article III.K and Article VII.E of this Disclosure Statement and Article VIII of the Second Amended Plan.</i></p>

D. Additional Plan Information and Plan Supplement

The information regarding the Second Amended Plan, the New WDT Documents and other Wind Down Documents contained in this Disclosure Statement is a summary and the Debtors encourage Holders of Claims and Interests to review the Second Amended Plan, the New WDT Documents and other Wind Down Documents for an understanding of the terms and conditions thereof, which Second Amended Plan, the New WDT Documents and other Wind Down Documents shall govern in the event of any inconsistency with this Disclosure Statement. The Wind Down Documents includes the Second Amended Plan, this Disclosure Statement, the Confirmation Order and the Plan Supplement, and the various agreements and other documentation formalizing the Second Amended Plan. The Debtors will file the Plan Supplement no later than five Business Days before the Voting Deadline. Prior to the Effective Date and in accordance with the terms of the Second Amended Plan and subject to the Proponents' Consent Right, the Plan Supplement may be modified, amended, supplemented, restated, or withdrawn after it is filed and such changes shall be made publicly available. The Plan Supplement will include the following information and documents, which shall be subject to the Proponents' Consent Right:

- the identity of the Wind Down Trustee;
- the identity of the Litigation Trustee;
- a schedule of the known Retained Causes of Action;
- a Schedule of Assumed Executory Contracts and Unexpired Leases;
- the form of Litigation Trust Agreement;

- the form of Wind Down Trust Agreement;
- the Wind Down Amount;
- the form of New WDT Documents, if any;
- the form of notice of Effective Date; and
- any other documentation necessary to effectuate or that is contemplated by the Second Amended Plan.

III. QUESTIONS AND ANSWERS REGARDING THIS DISCLOSURE STATEMENT AND THE SECOND AMENDED PLAN

A. What is chapter 11?

Chapter 11 refers to chapter 11 of title 11 of the United States Code and is the principal business reorganization chapter of the Bankruptcy Code. Chapter 11 promotes equality of treatment for creditors and similarly situated equity interest holders, subject to the priority of distributions prescribed by the Bankruptcy Code.

The commencement of a chapter 11 case creates an estate that comprises all of the legal and equitable interests of the debtor as of the date the chapter 11 case is commenced. The Bankruptcy Code provides that the debtor may continue to operate its business and remain in possession of its property as a “debtor in possession.” Consummating a chapter 11 plan and making distributions to holders of claims and interests is the principal objective of a chapter 11 case. A bankruptcy court’s confirmation of a plan binds the debtor, any person acquiring property under the plan, any creditor or equity interest holder of the debtor, and any other entity as may be ordered by the bankruptcy court. Subject to certain limited exceptions, the order issued by a bankruptcy court confirming a plan provides for the treatment of the debtor’s liabilities in accordance with the terms of the confirmed plan.

B. Why are the Debtors sending me this Disclosure Statement?

The Debtors are seeking to obtain Bankruptcy Court approval of the Second Amended Plan. Before soliciting acceptances of the Second Amended Plan, section 1125 of the Bankruptcy Code requires the Debtors to prepare a disclosure statement containing adequate information of a kind, and in sufficient detail, to enable a hypothetical reasonable investor to make an informed judgment regarding acceptance of the Second Amended Plan and to share such disclosure statement with all holders of claims or interests whose votes on the Second Amended Plan are being solicited. This Disclosure Statement is being submitted in accordance with these requirements.

C. Am I entitled to vote on the Second Amended Plan?

Your ability to vote on, and your distribution (if any) under, the Second Amended Plan depends on what type of Claim or Interest you hold. Each category of Holders of Claims or Interests, as set forth in Article III of the Second Amended Plan pursuant to section 1122(a) of the

Bankruptcy Code, is referred to as a “Class.” Each Class’s respective voting status is set forth below.

Class	Claims and Interests	Status	Voting Rights
Class 1	Other Secured Claims	Unimpaired	Deemed to Accept
Class 2	Other Priority Claims	Unimpaired	Deemed to Accept
Class 3	Bond Claims	Impaired	Entitled to Vote
Class 4(a)	General Unsecured Claims	Impaired	Entitled to Vote
Class 4(b)	GUC Convenience Claims	Unimpaired	Deemed to Accept
Class 5	DLP Entity General Unsecured Claims	Unimpaired	Deemed to Accept
Class 6	Intercompany Claims	Impaired	Deemed to Reject
Class 7	Intercompany Interests	Impaired	Deemed to Reject
Class 8	Series 1 Preferred Interests	Impaired	Entitled to Vote
Class 9	Series 2 Preferred Interests	Impaired	Entitled to Vote
Class 10	Existing Common Interests	Impaired	Entitled to Vote

D. What will I receive from the Debtors if the Second Amended Plan is consummated?

The following chart provides a summary of the anticipated recovery to Holders of Claims or Interests under the Second Amended Plan. Any estimates of Claims or Interests in this Disclosure Statement may vary from the final amounts allowed by the Bankruptcy Court. Your ability to receive distributions under the Second Amended Plan depends on the ability of the Debtors to obtain Confirmation and meet the conditions necessary to consummate the Second Amended Plan.

For certain Classes, the anticipated recoveries set forth herein are also tied to liquidating trust interests that will receive distributions based on the priority of such interests and the monetization of assets or realization of profits over time. Accordingly, cash distributions on account of such interests will not be paid immediately on the Effective Date.

Each Holder of an Allowed Claim or Allowed Interest, as applicable, shall receive under the Second Amended Plan the treatment described below in full and final satisfaction, compromise, settlement, release of, and in exchange for, such Holder’s Allowed Claim or Allowed Interest, except to the extent less favorable treatment is agreed to by the Debtors and the Holder of such Allowed Claim or Allowed Interest, as applicable. Unless otherwise indicated, the Holder of an Allowed Claim or Allowed Interest, as applicable, shall receive such treatment on the later of the Effective Date and the date such Holder’s Claim or Interest becomes an Allowed Claim or Allowed Interest or as soon as reasonably practicable thereafter.

THE PROJECTED RECOVERIES SET FORTH IN THE TABLE BELOW ARE ESTIMATES ONLY AND THEREFORE ARE SUBJECT TO CHANGE. FOR A COMPLETE DESCRIPTION OF THE DEBTORS’ CLASSIFICATION AND TREATMENT OF CLAIMS AND INTERESTS, REFERENCE SHOULD BE MADE TO THE ENTIRE SECOND AMENDED PLAN.

SUMMARY OF EXPECTED RECOVERIES			
Class	Claim / Interest	Treatment of Claim / Interest	Projected Amount of Allowed Claims or Interests / Projected Recovery Under the Second Amended Plan
Classified Claims and Interests			
1	Other Secured Claims	Except to the extent that a Holder of an Other Secured Claim agrees to a less favorable treatment of its Allowed Claim, on the Effective Date, each Holder of an Allowed Other Secured Claim shall receive, at the Debtors' option: (i) payment in full in Cash; (ii) the collateral securing its Allowed Other Secured Claim; (iii) Reinstatement of its Allowed Other Secured Claim; or (iv) such other treatment rendering its Allowed Other Secured Claim Unimpaired in accordance with section 1124 of the Bankruptcy Code.	<u>Estimated Allowed Claim Pool Amount:</u> \$0 <u>Estimated Recovery:</u> 100%
2	Other Priority Claims	Except to the extent that a Holder of an Allowed Other Priority Claim agrees to a less favorable treatment of its Allowed Claim, each Holder of an Allowed Other Priority Claim shall receive treatment in a manner consistent with section 1129(a)(9) of the Bankruptcy Code.	<u>Estimated Allowed Claim Pool Amount:</u> \$15,150 <u>Estimated Recovery:</u> 100%
3	Bond Claims	Except to the extent that a Holder of a Bond Claim agrees to a less favorable treatment of its Allowed Claim, each such Holder shall receive, as applicable, as follows: a. each Holder of an Allowed Bond Claim (other than the LBM Subordinated Claims) shall receive, on the Effective Date, its pro rata share of the Portfolio Proceeds Amount, if any; <i>provided, however</i> , that the Indenture Fee and Expense Claim shall be satisfied first from the Portfolio Proceeds Amount prior to any such further pro rata	<u>Estimated Allowed Claim Pool Amount:</u> \$1,672,852,358 <u>Estimated Recovery:</u> ³⁵ Bond Claims (other than LBM L Bond Claims and Indenture Trustee fees and

³⁵ Additional information regarding the valuation of the Debtors' assets is set forth in Article II.A of this Disclosure Statement, the Valuation Analysis attached hereto as **Exhibit C**, and the Liquidation Analysis attached hereto as **Exhibit E**.

		<p>distributions in accordance with this subsection of the Second Amended Plan;</p> <p>b. each Holder of an Allowed Bond Claim (other than the LBM Subordinated Claims) shall receive, on the Effective Date (or as soon as practicably thereafter), its pro rata share of the New Series A1 WDT Interests. The New Series A1 WDT Interests may be redeemed at any time without penalty at stated value and, pending any such redemption, shall be entitled to Cash distributions pursuant to the priority of payment waterfalls described in <u>Article IV.H</u> and <u>Article VI.C</u> of the Second Amended Plan. Any New Series A1 WDT Interests issued to the Indenture Trustee on account of any outstanding Indenture Fee and Expense Claims shall be expressly senior in all respects to any New Series A1 WDT Interests issued to Holders on account of their respective Allowed Class 3 Bond Claims; and</p> <p>c. each Holder of an Allowed LBM Subordinated Claim shall receive, on the Effective Date, its pro rata share of the New Series A2 WDT Interests. The New Series A2 WDT Interests may be redeemed at any time without penalty at stated value and, pending any such redemption, shall be entitled to Cash distributions, but only pursuant to the priority of payment waterfalls described in <u>Article IV.H</u> and <u>Article VI.C</u> of the Second Amended Plan.</p> <p>The pro rata distributions on account of the Allowed Class 3 Bond Claims shall be calculated based upon the sum of the aggregate amount of Allowed Class 3 Bond Claims (less any LBM Subordinated Claims) as of the Petition Date with respect to subsections (a) and (b) above, and the sum of the aggregate amount</p>	<p>expenses): 9.0% – 100%³⁶</p> <p>LBM L Bond Claims: 7.7% – 100%</p>
--	--	---	--

³⁶ At the high end of the range, Bondholders may receive total proceeds in excess of their estimated Allowed Claims due to the potential payment of interest accruing on the New Series A1 WDT Interests at rate of 9% per annum under the Second Amended Plan.

		of Allowed LBM Subordinated Claims as of the Petition Date with respect to subsection (c) above, and after accounting for each Holder's receipt of its pro rata share of the Portfolio Proceeds Amount, as applicable.	
4(a)	General Unsecured Claims	Except to the extent that a Holder of a General Unsecured Claim agrees to a less favorable treatment of its Allowed Claim, on the Effective Date, each Holder of an Allowed General Unsecured Claim shall receive its pro rata share of the New Series B WDT Interests. The New Series B WDT Interests may be redeemed at any time without penalty at stated value and, pending any such redemption, shall be entitled to Cash distributions, but only pursuant to the priority of payment waterfalls described in <u>Article IV.H</u> and <u>Article VI.C</u> of the Second Amended Plan.	<u>Estimated Allowed Claim Pool Amount:</u> \$20,278,288 <u>Estimated Recovery:</u> 8.5% – 21.9%
4(b)	GUC Convenience Claims	<p>Except to the extent that a Holder of a GUC Convenience Claim agrees to a less favorable treatment of its Allowed Claim, in full and final satisfaction, settlement, release, and discharge of, and in exchange for each Allowed GUC Convenience Claim, each Holder thereof shall receive, and the option of the applicable Debtor, either:</p> <p>(i) payment in full in Cash of the due and unpaid portion of its Allowed GUC Convenience Claim on the later of (x) the Effective Date (or as soon thereafter as reasonably practicable), or (y) as soon as practicable after the date such Claim becomes due and payable; or</p> <p>(ii) such other treatment rendering its Allowed GUC Convenience Claim Unimpaired.</p> <p>Pursuant to the Second Amended Plan, a "<u>GUC Convenience Claim</u>" means an Allowed Claim in an amount greater than \$0.01 but less than or equal to \$2,750.00, that would otherwise qualify as a General Unsecured Claim; <i>provided</i>, that any Holder of an Allowed General Unsecured</p>	<u>Estimated Allowed Claim Pool Amount:</u> \$83,335 ³⁷ <u>Estimated Recovery:</u> 100%

³⁷ Estimate assumes that every Holder with an Allowed Claim of less than \$10,000 will make such election.

		Claim may elect to have such Claim reduced to \$2,750.00 and treated as an Allowed GUC Convenience Claim for purposes of the Second Amended Plan; <i>provided, further,</i> that notwithstanding the foregoing, the total GUC Convenience Claims shall not exceed \$150,000 in the aggregate.	
5	DLP Entity General Unsecured Claims	On the Effective Date or as soon thereafter as such Claim becomes an Allowed Claim, each Holder of an Allowed DLP Entity General Unsecured Claim shall receive payment in full in Cash.	<u>Estimated Allowed Claim Pool Amount:</u> \$0 <u>Estimated Recovery:</u> 100%
6	Intercompany Claims	Other than the Policy Portfolio Equity Interests, which shall be transferred to the Wind Down Trust as set forth in the Second Amended Plan, on the Effective Date, any Debtor's Claim against any other Debtor shall be deemed satisfied except to the extent necessary to effectuate the other terms of the Second Amended Plan.	<u>Estimated Allowed Claim Pool Amount:</u> N/A <u>Estimated Recovery:</u> N/A
7	Intercompany Interests	On the Effective Date, any Debtor's equity Interests in any other Debtor shall be deemed cancelled except to the extent necessary to effectuate the other terms of the Second Amended Plan.	<u>Estimated Allowed Claim Pool Amount:</u> N/A <u>Estimated Recovery:</u> N/A
8	Series 1 Preferred Interests	On the Effective Date, and in all instances, each Holder of a Series 1 Preferred Interest shall receive its pro rata share of the New Series C WDT Interests. The New Series C WDT Interests may be redeemed at any time without penalty at stated value and, pending any such optional redemption, shall be entitled to Cash distributions, but only pursuant to the priority of payment waterfalls described in <u>Article IV.H</u> and <u>Article VI.C</u> of the Second Amended Plan. The New Series C WDT Interests shall rank junior in right of payment to the New Series A1 WDT Interests, the New Series A2 WDT Interests, and the New Series B WDT Interests, <i>pari passu</i> with the New Series D WDT Interests, and senior to the New Series E WDT Interests.	<u>Estimated Allowed Claim Pool Amount:</u> \$42,622,169 <u>Estimated Recovery:</u> 0%

9	Series 2 Preferred Interests	On the Effective Date, and in all instances, each Holder of a Series 2 Preferred Interest shall receive its pro rata share of the New Series D WDT Interests. The New Series D WDT Interests may be redeemed at any time without penalty at stated value and, pending any such optional redemption, shall be entitled to Cash distributions, but only pursuant to the priority of payment waterfalls described in <u>Article IV.H</u> and <u>Article VI.C</u> of the Second Amended Plan. The New Series D WDT Interests shall rank junior in right of payment to the New Series A1 WDT Interests, the New Series A2 WDT Interests, and the New Series B WDT Interests, <i>pari passu</i> with the New Series C WDT Interests, and senior to the New Series E WDT Interests.	<u>Estimated Allowed Claim Pool Amount:</u> \$88,140,766 <u>Estimated Recovery:</u> 0%
10	Common Stock in GWGH	On the Effective Date, each Holder of Common Stock in GWGH shall receive its pro rata share of the New Series E WDT Interests. The holders of the New Series E WDT Interests shall only be entitled to Cash distributions upon the satisfaction and redemption of all other classes of New WDT Interests, pursuant to the priority of payment waterfalls described in <u>Article IV.H</u> and <u>Article VI.C</u> of the Second Amended Plan.	<u>Estimated Allowed Claim Pool Amount:</u> N/A <u>Estimated Recovery:</u> N/A

E. What will I receive from the Debtors if I hold an Allowed Administrative Claim, Allowed Accrued Professional Compensation Claim, Allowed Chapford DIP Facility Claim, Allowed Vida DIP Claim, Allowed DLP Secured Claim, Allowed Indenture Diminution Claim, Allowed Priority Tax Claim, or Allowed Substantial Contribution Claim?

In accordance with section 1123(a)(1) of the Bankruptcy Code, Administrative Claims, Accrued Professional Compensation Claims, Chapford DIP Facility Claims, Vida DIP Claims, DLP Secured Claims, Priority Tax Claims and Indenture Diminution Claims have not been classified and, thus, are excluded from the Classes of Claims and Interests set forth in Article III of the Second Amended Plan.

1. Administrative Claims

Except as otherwise agreed to by the Holder of an Allowed Administrative Claim and the Debtors or Wind Down Debtors or as provided in the Second Amended Plan, on the Administrative Claims Payment Date (or within a reasonable period of time after such Claims become Allowed Claims), each Holder of an Allowed Administrative Claim shall receive payment in full in Cash

in full and final satisfaction, settlement, discharge, and release of such Allowed Administrative Claim in accordance with the following: (1) if an Administrative Claim is Allowed on or prior to the Effective Date, on the Effective Date or as soon as reasonably practicable thereafter (or, if not then due, when such Allowed Administrative Claim is due or as soon as reasonably practicable thereafter); (2) if such Administrative Claim is not Allowed as of the Effective Date, no later than 30 days after the date on which an order Allowing such Administrative Claim becomes a Final Order, or as soon as reasonably practicable thereafter; (3) if such Allowed Administrative Claim is based on liabilities incurred by the Debtors in the ordinary course of their business after the applicable Petition Date in accordance with the terms and conditions of the particular transaction giving rise to such Allowed Administrative Claim without any further action by the Holder of such Allowed Administrative Claim; (4) at such time and upon such terms as may be agreed upon by such Holder and the Debtors or the Wind Down Debtors, as applicable; or (5) at such time and upon such terms as set forth in an order of the Bankruptcy Court.

EXCEPT AS OTHERWISE PROVIDED BY THE SECOND AMENDED PLAN, THE CONFIRMATION ORDER, OR A FINAL ORDER PREVIOUSLY ENTERED BY THE BANKRUPTCY COURT (INCLUDING THE FINAL VIDA ORDER), UNLESS PREVIOUSLY FILED, REQUESTS FOR PAYMENT OF ADMINISTRATIVE CLAIMS MUST BE FILED AND SERVED ON THE DEBTORS (OR THE WIND DOWN DEBTORS, AS APPLICABLE) NO LATER THAN THE CLAIMS BAR DATE APPLICABLE TO ADMINISTRATIVE CLAIMS PURSUANT TO THE PROCEDURES SPECIFIED IN THE CONFIRMATION ORDER AND THE NOTICE OF THE EFFECTIVE DATE; PROVIDED, THAT THE FOREGOING SHALL NOT APPLY TO ACCRUED PROFESSIONAL COMPENSATION CLAIMS, INDEPENDENT DIRECTOR FEE CLAIMS, THE INDENTURE DIMINUTION CLAIMS, THE ALLOWED AHC SUBSTANTIAL CONTRIBUTION CLAIM, OR CLAIMS ARISING UNDER SECTION 503(b)(1)(D) OF THE BANKRUPTCY CODE.

HOLDERS OF ADMINISTRATIVE CLAIMS THAT ARE REQUIRED TO FILE AND SERVE A REQUEST FOR PAYMENT OF SUCH ADMINISTRATIVE CLAIMS BY THE CLAIMS BAR DATE APPLICABLE TO ADMINISTRATIVE CLAIMS THAT DO NOT FILE AND SERVE SUCH A REQUEST BY THE CLAIMS BAR DATE APPLICABLE TO ADMINISTRATIVE CLAIMS SHALL BE FOREVER BARRED, ESTOPPED, AND ENJOINED FROM ASSERTING SUCH ADMINISTRATIVE CLAIMS AGAINST THE DEBTORS, THE WIND DOWN DEBTORS, THE DEBTORS' ESTATES, OR THEIR RESPECTIVE PROPERTY, AND SUCH ADMINISTRATIVE CLAIMS SHALL BE DEEMED DISCHARGED AS OF THE EFFECTIVE DATE. ALL SUCH CLAIMS SHALL BE SUBJECT TO THE PERMANENT INJUNCTION SET FORTH IN ARTICLE VIII.G OF THE SECOND AMENDED PLAN.

2. Accrued Professional Compensation Claims

(a) Professional Fee Escrow Account.

No later than one Business Day prior to the Effective Date, the Debtors shall fund the Professional Fee Escrow Account with the Debtors' Cash on hand in the amount of the aggregate Professional Fee Escrow Amount for all Professionals; *provided* that each Professional's

respective share of the Professional Fee Escrow Account shall be reduced, on a dollar-for-dollar basis, by any unused retainer held by such Professional as of the Effective Date.³⁸ The Professional Fee Escrow Account shall be maintained in trust for the Professionals and the funds held in the Professional Fee Escrow Account shall not be considered property of the Debtors' Estates or any successor to the Debtors; *provided* that, notwithstanding the foregoing, the Wind Down Trust shall have a reversionary interest in the excess, if any, of the amount of the Professional Fee Escrow Account over the aggregate Allowed Accrued Professional Compensation Claims to be paid from the Professional Fee Escrow Account, and such excess shall be paid to the Wind Down Debtors (and distributed to the Wind Down Trust, if determined by the Wind Down Trustee) without any further notice to or action, order, or approval of the Bankruptcy Court or any other Entity.

(b) *Final Fee Applications and Payment of Accrued Professional Compensation Claims.*

All final requests for payment of Claims of a Professional for services rendered and reimbursement of expenses incurred prior to the Confirmation Date shall be Filed no later than the first Business Day that is 60 days after the Confirmation Date. After notice and an opportunity for a hearing in accordance with the procedures established by the Bankruptcy Code and prior Bankruptcy Court orders, the Allowed amounts of such Accrued Professional Compensation Claims shall be determined by the Bankruptcy Court. The amount of Accrued Professional Compensation Claims owing to the applicable Professionals shall be paid in Cash to such Professionals from funds held in the Professional Fee Escrow Account after such Claims are Allowed by a Final Order. After all Accrued Professional Compensation Claims have been paid in full, the Final Order Allowing such Accrued Professional Compensation Claims shall direct the escrow agent to return any excess amounts to the Wind Down Trustee without further notice to or action, order, or approval of the Bankruptcy Court or any other Entity.

(c) *Estimate of Professional Fee Compensation Claims.*

To receive payment for unbilled fees and expenses incurred through the Confirmation Date, the Professionals shall provide a reasonable and good faith estimate of their Accrued Professional Compensation Claims before and as of the Confirmation Date and shall deliver such estimate to the Debtors no later than three Business Days before the Confirmation Date; *provided*, that such estimate shall not be considered an admission with respect to the fees and expenses of such Professional and such Professionals are not bound to any extent by the estimates. If a Professional does not provide an estimate, the Debtors may estimate the unbilled fees and expenses of such

³⁸ For the avoidance of doubt, nothing contained in the Second Amended Plan shall be deemed to resolve any of the issues relating to the payment of fees and expenses for services rendered by Willkie Farr & Gallagher, LLP prior to the Petition Date, including with respect to all Cash held as a retainer by the Debtors or Willkie Farr & Gallagher, LLP pursuant to the *Order Modifying the Automatic Stay and Authorizing the Use of Estate Property, to the Extent Applicable, to Allow Payment, Reimbursement and/or Advancement of Defense Costs Under the Insurance Policies* [Docket. No. 754] (the "D&O Insurance Order") and the *Stipulation and Agreed Order Regarding the Order Modifying the Automatic Stay and Authorizing Use of Estate Property, to the Extent Applicable, to Allow Payment, Reimbursement and/or Advancement of Defense Costs Under Insurance Policies* [Docket. No. 825]. In accordance with the D&O Insurance Order, any and all such issues remain subject to resolution through either (i) further order of the Bankruptcy Court or (ii) agreement between the Debtors (or, if after the Effective Date, the Wind Down Trustee), Willkie Farr & Gallagher, LLP, and the Bondholder Committee (or, if after the Effective Date, the Litigation Trustee).

Professional; *provided, further*, that such estimate shall not be binding or considered an admission with respect to the fees and expenses of such Professional.

(d) *Post-Confirmation Fees and Expenses.*

Except as otherwise specifically provided in the Second Amended Plan, from and after the Confirmation Date, the Debtors shall, in the ordinary course of business and without any further notice to or action, order, or approval of the Bankruptcy Court, pay in Cash the reasonable and documented legal, professional, or other fees and expenses related to implementation and Consummation of the Second Amended Plan incurred by the Debtors or the Bondholder Committee; *provided*, that each Entity seeking such payment shall promptly provide copies of its invoices to the Debtors or the Wind Down Trustee, as applicable, and the Bondholder Committee, and the Bankruptcy Court shall have exclusive jurisdiction over any objections raised to the amount of the fees and expenses proposed to be paid, which objections may only be raised within 14 days after receipt thereof. In the event that within 14 days from receipt of such invoices, the Debtors or the Wind Down Trustee, as applicable, or the Bondholder Committee raises an objection to a particular invoice, and the parties are unable to resolve any dispute regarding the fees and expenses included in such invoice, the Bankruptcy Court shall hear and determine such dispute. Upon the Confirmation Date, any requirement that Professionals and Ordinary Course Professionals comply with sections 327 through 331 and 1103 of the Bankruptcy Code, the Interim Compensation Order, or the Ordinary Course Professionals Order, in seeking retention or compensation for services rendered after such date shall terminate, and the Debtors or the Wind Down Trustee, as applicable, may employ and pay any Professional or Ordinary Course Professional in the ordinary course of business without any further notice to or action, order, or approval of the Bankruptcy Court. Furthermore, as of the date one day prior to the Effective Date, the obligation of any Ordinary Course Professional to File a fee application pursuant to the Ordinary Course Professionals Order shall be deemed waived, and, on the Effective Date, the Debtors or the Wind Down Trustee, as applicable, may pay any Ordinary Court Professional for fees incurred or accrued after the Effective Date in the ordinary course of business without any further notice to or action, order, or approval of the Bankruptcy Court.

3. Chapford DIP Facility Claims

On or prior to the Effective Date, and to the extent each such Chapford DIP Facility Claims have not previously been satisfied in full in connection with the consummation of the Vida DIP Financing Facility or otherwise, each Holder of an Allowed Chapford DIP Facility Claim shall receive payment in full in Cash; *provided, however*, for the avoidance of doubt, the Chapford DIP Facility Claims shall not include the purported Alternate Stalking Horse Fee, as defined and referenced in the Chapford Final DIP Order (including any professional fees and expenses relating in any manner to the assertion of the purported Alternate Stalking Horse Fee).

4. Vida DIP Claims

No later than the Effective Date, the Vida DIP Claims will be deemed satisfied in connection with the Debtors' exercise of the exit financing option and upon the closing under the Vida Exit Financing Facility Documents.

5. DLP Secured Claims

All Allowed DLP Secured Claims will be satisfied by payment in full in Cash on or prior to the Effective Date from proceeds of the Vida DIP Financing Facility; *provided*, that, notwithstanding the foregoing, to the extent that all Allowed DLP Secured Claims are not paid in full in cash before the Effective Date, they shall be treated as Other Secured Claims. Any Disputed portion of the DLP Secured Claims shall be treated in accordance with Article VII of the Second Amended Plan.

6. Indenture Diminution Claims

Any Allowed Indenture Diminution Claims will be satisfied by one or more payments in Cash after the Effective Date from proceeds realized by the Litigation Trust, pursuant to and in accordance with Article VI.C of the Second Amended Plan.

7. Priority Tax Claims

Except to the extent that a Holder of an Allowed Priority Tax Claim agrees to a less favorable treatment, in full and final satisfaction, settlement, and release of and in exchange for each Allowed Priority Tax Claim, each Holder of such Allowed Priority Tax Claim shall be treated in accordance with the terms set forth in section 1129(a)(9)(C) of the Bankruptcy Code.

8. Allowed AHC Substantial Contribution Claim

In full and final resolution of any claims that the Ad Hoc Broker/Dealer Committee could assert for making a substantial contribution to these Chapter 11 Cases, the Debtors agree to pay the actual and reasonable fees and expenses of the Ad Hoc Broker/Dealer Committee not to exceed \$1,000,000.

9. Substantial Contribution Compensation and Expenses

Any Entity that requests compensation or expense reimbursement for making a substantial contribution in the Chapter 11 Cases pursuant to Bankruptcy Code sections 503(b)(3), (4), and (5) (except with respect to the Allowed AHC Substantial Contribution Claim) must File an application and serve such application on counsel to the Debtors or the Wind Down Debtors, as applicable, and the Bondholder Committee and as otherwise required by the Bankruptcy Court, the Bankruptcy Code, and the Bankruptcy Rules, on or before the Claims Bar Date applicable to Administrative Claims.

F. Are any regulatory approvals required to consummate the Second Amended Plan?

To the extent any governmental approval or consent is necessary in connection with the transactions to be consummated in connection with the Effective Date of the Second Amended Plan, such governmental approval or consent, if any, will be obtained in order for the Second Amended Plan to become effective on the Effective Date.

G. What happens to my recovery if the Second Amended Plan is not confirmed or does not go effective?

In the event that the Second Amended Plan is not confirmed or does not go effective, there is no assurance that the Company will be able to implement the liquidating trusts pursuant to the Second Amended Plan and any other Wind Down Transactions, and therefore there can be no assurances that any creditors will receive the recovery from the estates described herein. It is possible that any alternative may provide Holders of Claims or Interests with less than they would have received pursuant to the Second Amended Plan. For a more detailed description of the consequences of an extended chapter 11 case, or of a liquidation scenario, see Article X.A.1 of this Disclosure Statement, entitled “Best Interests of Creditors” and the Liquidation Analysis attached hereto as **Exhibit E**.

H. If the Second Amended Plan provides that I get a distribution, do I get it upon Confirmation or when the Second Amended Plan goes effective? What is meant by “Confirmation,” “Effective Date” and “Consummation”?

“Confirmation” of the Second Amended Plan refers to approval of the Second Amended Plan by the Bankruptcy Court. Confirmation of the Second Amended Plan does not guarantee that you will receive the distribution indicated under the Second Amended Plan. After Confirmation of the Second Amended Plan by the Bankruptcy Court, there are conditions that must be satisfied or waived so that the Second Amended Plan can go effective. Initial distributions to Holders of Allowed Claims or Allowed Interests will only be made on the date the Second Amended Plan becomes effective—the “Effective Date”—or as soon as reasonably practicable thereafter, as specified in the Second Amended Plan. *See Article VII.F* of this Disclosure Statement entitled “Conditions Precedent to the Effective Date” for a discussion of the conditions precedent to Consummation of the Second Amended Plan. “Consummation” refers to “substantial consummation” of the Second Amended Plan, as defined in section 1101(2) of the Bankruptcy Code, and means (i) the transfer of all or substantially all of the property proposed by the Second Amended Plan to be transferred; (ii) assumption by the Debtors or by the successors to the Debtors under the Second Amended Plan of the business or of the management of all or substantially all of the property dealt with by the Second Amended Plan; and (iii) commencement of distributions under the Second Amended Plan.

I. Is there potential litigation related to confirmation of the Second Amended Plan?

Parties in interest may object to Confirmation of the Second Amended Plan, which objections potentially could give rise to litigation. In addition, if it becomes necessary to confirm the Second Amended Plan over the rejection of certain Classes, the Debtors may seek confirmation of the Second Amended Plan notwithstanding the dissent of such rejecting Classes pursuant to the “cramdown” provisions of the Bankruptcy Code, which allow the Bankruptcy Court to confirm a plan that has been rejected by an impaired Class if it determines that the Second Amended Plan satisfies section 1129(b) of the Bankruptcy Code. *See Article VIII.A.3* of this Disclosure Statement, entitled “The Debtors May Not Be Able to Secure Confirmation of the Second Amended Plan.”

J. Will the final amount of the allowed claims or interests in a particular class affect the recovery of holders of allowed claims or interests in such class or in other classes under the Second Amended Plan?

The chart provided above (*see* Article III.D of this Disclosure Statement entitled “What will I receive from the Debtors if the Second Amended Plan is consummated?”) sets forth the Debtors’ estimates of the aggregate amount of Allowed Claims or Interests in each Class. In particular, the Debtors estimate that Class 3 Claims (i.e., Bond Claims) will be Allowed in an aggregate amount of approximately \$1,672,852,358, Class 4(a) Claims (i.e., General Unsecured Claims) will be Allowed in an aggregate amount of approximately \$20,278,288, Class 8 Claims (i.e., Series 1 Preferred Interests) will be Allowed in an aggregate amount of approximately \$42,622,169, and Class 9 Claims (i.e., Series 2 Preferred Interests) will be Allowed in an aggregate amount of approximately \$88,140,766. Although the Debtors’ estimate of Allowed Claims or Interests in the foregoing classes is the result of the Debtors’ and their advisors’ careful analysis of available information, the actual Allowed Claims or Interests may be materially higher or lower than the Debtors’ estimates provided herein.

Holders of Allowed Claims or Interests in the Classes described in the above paragraph (Classes 3, 4(a), 8 and 9) and in Class 10 (GWGH Common Stock) each receive interests in the Wind Down Trust that will receive distributions pursuant to a waterfall structure in which the Class(es), if any, that are senior to any particular Class are paid in full before such Class receives distributions. The final amount of Allowed Claims or Interests could affect recoveries to Holders of a particular Class in a few different ways. First, if Allowed Claims or Interests in Class(es) that are senior to your Class are greater than the Debtors’ estimate, then more distributions will go to such senior Class(es) before distributions begin to be made to your Class. On the other hand, if Allowed Claims or Interests in Class(es) that are senior to your Class are less than the Debtors’ estimate, then fewer distributions will go to such senior Class(es) and your Class will be entitled to distributions sooner. Second, if Allowed Claims or Interests in the same Class as your Class and any *pari passu* Classes are greater than the Debtors’ estimate, then, once your Class is entitled to distributions, those distributions will be shared pro rata among all the Claims or Interests in your Class and any *pari passu* Classes and your pro rata share of such distributions will be less. On the other hand, if Allowed Claims or Interests in the same Class as your Class and any *pari passu* Classes are less than the Debtors’ estimate, then your pro rata share of such distributions will be greater.

The projected amount of Allowed Claims or Interests in each Class set forth herein is subject to change. For example, any change in the number, identity, or timing of actual rejected Executory Contracts and Unexpired Leases could have a material impact on the amount of Allowed General Unsecured Claims. To the extent that the actual amount of rejection damages Claims changes, the value of recoveries to Holders of Allowed General Unsecured Claims could change as well, and such changes could be material.

Further, as of the applicable Petition Date, the Debtors were parties to certain litigation matters that arose in the ordinary course of operating their businesses and could become parties to additional litigation in the future as a result of conduct that occurred prior to the applicable Petition Date. Although the Debtors have disputed, are disputing, or will dispute in the future the amounts asserted by such litigation counterparties, to the extent these parties are ultimately entitled to a

higher amount than is reflected in the amounts estimated by the Debtors herein, the value of recoveries to Holders of Allowed Claims or Interests could change as well, and such changes could be material.

Finally, the Debtors, the Bondholder Committee, or other parties in interest may object to Proofs of Claim, and the results of such objection proceedings ultimately could cause the total amount of Allowed Claims or Interests in a particular Class to change. These changes could affect recoveries to Holders of Allowed Claims or Interests in such Class, and such changes could be material.

K. Will there be releases and exculpation granted to parties in interest as part of the Second Amended Plan?

Yes, the Second Amended Plan contains releases by the Debtors and exculpation of certain parties. **However, other than to the extent provided in the Debtor release or exculpation provisions, the Second Amended Plan does not contain third party releases, including releases by Holders of Claims or Interests. Accordingly, Holders of Claims or Interests will not be requested to “opt in” or “opt out” of any releases under the Second Amended Plan.**

Only those entities specifically included in the definition of Released Parties and Exculpated Parties shall be released or exculpated, respectively, pursuant to the Second Amended Plan. In addition, the Second Amended Plan specifically identifies certain Non-Released Parties who shall not be released or exculpated pursuant to the Second Amended Plan. The Debtors’ releases and exculpation provisions included in the Second Amended Plan are an integral part of the Debtors’ overall restructuring efforts.

Under the Second Amended Plan, the Debtors, the Wind Down Debtors, their Estates, and certain related parties, release the “Released Parties” from claims that arise before the Effective Date in accordance with the provisions of Article VIII.C therein. “Released Party” means, collectively, and in each case in their respective capacities as such and subject to the limitations set forth in Article VIII.C of the Second Amended Plan: (a) (i) the Debtors and the Wind Down Debtors, (ii) Vida, (iii) the Bondholder Committee and each of its members, (iv) Anthony R. Horton, in his capacities as an Independent Director and director of the Debtors, (v) Jeffrey S. Stein, in his capacities as an officer, an Independent Director, and a director of the Debtors, (vi) Michael A. Tucker, in his capacity as an officer of the Debtors, (vii) the DLP Independent Directors, (viii) FTI Consulting, Inc., (ix) PJT Partners LP, and (x) any other Professional retained by the Debtors, the Independent Directors, the DLP Independent Directors, or the Bondholder Committee by order of the Bankruptcy Court in the Chapter 11 Cases or any professional retained by any of the members of the Bondholder Committee, each in such capacity; and (b) solely to the extent and on the terms and conditions set forth in the Second Amended Plan, the LBM Released Parties.

The Second Amended Plan makes clear that any Entity that is not a Released Party is a “Non-Released Party,” including, without limitation, Beneficient, its current and former directors and officers (including, without limitation, Bradley K. Heppner, Thomas O. Hicks, Bruce W. Schnitzer, Dennis P. Lockhart, and Peter T. Cangany), HCLP Nominees, L.L.C., the Debtors’ former directors and officers (including, without limitation, Murray Holland and Timothy Evans)

in their capacity or capacities as such, and any Entities affiliated with or otherwise related to the foregoing.

The releases set forth in Second Amended Plan do not release the Debtors' prepetition legal counsel solely with respect to claims or causes of action arising from such counsel's prepetition advice to the Debtors and/or any former directors or officers of the Debtors other than advice directly relating to the preparation and filing of the Chapter 11 Cases (it being understood any prepetition advice to the Debtors relating to prepetition transactions between the Debtors and Beneficient shall not constitute advice directly relating to the preparation and filing of the Chapter 11 Cases).

The Second Amended Plan also provides that Exculpated Parties will be deemed released and exculpated from Exculpated Claims, as set forth in Article VIII.E therein. An "Exculpated Party" means, collectively, and in each case, in their respective capacities as such: (a) Jeffrey S. Stein, in his capacities as an officer, an Independent Director, and a director of the Debtors; (b) Anthony R. Horton, in his capacities as an Independent Director and director of the Debtors; (c) Michael A. Tucker, in his capacity as an officer of the Debtors; (d) the Non-Management Directors, in their capacity as such; (e) the DLP Independent Directors, in their capacity as such; (f) the members of the Bondholder Committee, in their capacity as such; (g) any Professional retained by the Debtors, the Independent Directors, the DLP Independent Directors, the Bondholder Committee, in such Professionals' capacity as such; and (h) any professional retained by any of the members of the Bondholder Committee, each in such professionals' capacity as such.

An "Exculpated Claim" means any claim related to any act or omission from the Petition Date to the Effective Date in connection with, relating to, or arising out of: (a) the Chapter 11 Cases; (b) the formulation, preparation, dissemination, or negotiation of any document in connection with the Chapter 11 Cases; (c) any contract, instrument, release, and/or other agreement or document created or entered into in connection with the Chapter 11 Cases; (d) the pursuit of Consummation; and/or (e) the Filing, administration, and/or implementation of the Chapter 11 Cases, or the distribution of property in connection therewith or thereunder; *provided*, that, for the avoidance of doubt, any prepetition advice provided by any legal professionals in connection with prepetition transactions between the Debtors and Beneficient shall not constitute any act or omission that is covered by this definition of Exculpated Claim; *provided, further*, that, notwithstanding the foregoing, Exculpated Claims shall not include anything related to any act or omission that is determined in a Final Order to have constituted actual fraud, willful misconduct, intentional breach of fiduciary duty, or gross negligence.

The Released Parties and the Exculpated Parties have made substantial and valuable contributions to the Debtors' restructuring through efforts to negotiate and implement the Second Amended Plan, which will maximize and preserve the value of the Debtors for the benefit of all parties in interest. Accordingly, each of the Released Parties and the Exculpated Parties is entitled to the benefit of the release and exculpation provisions.

Based on the foregoing, the Debtors believe that the releases and exculpations in the Second Amended Plan are necessary and appropriate and meet the requisite legal standard promulgated by the United States Court of Appeals for the Fifth Circuit. Moreover, the Debtors will present evidence at the Confirmation Hearing to demonstrate the basis for and propriety of

the release and exculpation provisions. The release, exculpation, and injunction provisions that are contained in the Second Amended Plan are copied in Article VII.E of this Disclosure Statement.

L. What is the deadline to vote on the Second Amended Plan?

The Voting Deadline is **May 31, 2023 at 4:00 p.m. (prevailing Central Time)**.

M. How do I vote for or against the Second Amended Plan?

Detailed instructions regarding how to vote on the Second Amended Plan are contained on the Ballots distributed to Holders of Claims and Interests that are entitled to vote on the Second Amended Plan. For your vote to be counted, your Ballot must be properly completed, executed, and delivered as directed, so that your Ballot including your vote is **actually received** by Donlin, Recano & Company, Inc. (“DRC” or the “Notice and Solicitation Agent”) **on or before the Voting Deadline, i.e., May 31, 2023 at 4:00 p.m. prevailing Central Time.** See Article IX of this Disclosure Statement, entitled “SOLICITATION, VOTING PROCEDURES AND CONFIRMATION HEARING.”

N. What are the consequences of filing a late proof of claim?

Pursuant to the Bar Date Order,³⁹ the Bankruptcy Court established July 29, 2022 as the general claims bar date and October 17, 2022 (which was extended solely with respect to the SEC by stipulation to November 30, 2022) as the governmental claims bar date. Additionally, pursuant to the Bondholder Claim Procedures Order,⁴⁰ the Bankruptcy Court established November 4, 2022 at 11:59 p.m. (prevailing Central Time) as the Bondholder Bar Date. Other than Bond Claims (including claims of the Indenture Trustee) and certain other claims as agreed with the Debtors, Claims that were not received by the dates set forth in the Bar Date Order may be disallowed and the Holders of such Claims may not be entitled to vote on the Second Amended Plan.

Pursuant to the Bondholder Claim Procedures Order, the Debtors have provided to Bondholders who hold their Bonds directly individualized notices that identify, with respect to each Bond or Bondholder, the amount of principal and interest that is owing with respect to such Bond or to such Bondholder, as reflected in the Debtors’ books and records as of the Initial Debtors’ Petition Date. Such Bond Claims are deemed allowed secured claims following the Bondholder Bar Date, except to the extent a Bondholder has filed a Proof of Claim disputing such amount. Bondholders who hold their Bonds indirectly through The Depository Trust Company (“DTC”) were provided notices indicating that their Bond Claims would be Allowed upon entry of the Bondholder Claim Procedures Order without the need to file a Proof of Claim.

Subject to, and as set forth in more detail in, the procedures set forth in Exhibit 3 of the Disclosure Statement Order (the “Solicitation Procedures”), Holders of Interests (preferred stock

³⁹ See Order Setting Bar Dates for Filing Proofs of Claim [Docket No. 126] (the “Bar Date Order”).

⁴⁰ See Order (I) Modifying Bar Date Order, (II) Establishing Procedures for Allowance of Bondholder and Indenture Trustee Claims, and (II) Granting Related Relief [Docket No. 739] (the “Bondholder Claim Procedures Order”). Capitalized terms used but not defined in this section shall have the meaning ascribed to them in the Bondholder Claim Procedures Order.

and equity) in Debtor GWGH will be entitled to vote to accept or reject the Second Amended Plan irrespective of whether they have filed proofs of interest.

O. Why is the Bankruptcy Court holding a Confirmation Hearing and when is the Confirmation Hearing set to occur?

Section 1128(a) of the Bankruptcy Code requires the Bankruptcy Court, after notice, to hold a hearing on Confirmation of the Second Amended Plan. The Bankruptcy Court has scheduled the Confirmation Hearing for **June 15, 2023 at 1:30 p.m. (prevailing Central Time)**. The Confirmation Hearing may be adjourned from time to time without further notice.

Section 1128(b) of the Bankruptcy Code also provides that any party in interest may object to Confirmation of the Second Amended Plan. The Bankruptcy Court has established **May 31, 2023 at 11:59 p.m. (prevailing Central Time)**, as the deadline to object to Confirmation of the Second Amended Plan (the “Plan Objection Deadline”). All objections to the Second Amended Plan’s Confirmation must be filed with the Bankruptcy Court and served on the Debtors and certain other parties in interest in accordance with the order approving the Disclosure Statement and Solicitation Procedures so that they are actually received on or before the Plan Objection Deadline. Any objection to the Second Amended Plan must (1) be in writing; (2) conform to the Bankruptcy Rules, the Bankruptcy Local Rules, and any orders of the Bankruptcy Court; (3) state the name, address, phone number, and e-mail address of the objecting party and the amount and nature of the Claim or Interest of such entity, if any; (4) state, with particularity, the legal and factual basis for the objection and, if practicable, a proposed modification to the Second Amended Plan (or related materials) that would resolve such objection; and (5) be filed with the Bankruptcy Court (contemporaneously with a proof of service) and served upon the Debtors and certain other parties in interest in accordance with the order approving the Disclosure Statement and Solicitation Procedures so to be *actually received* on or before the Plan Objection Deadline. Unless an objection to the Second Amended Plan is timely served and filed, it may not be considered by the Bankruptcy Court.

P. Who do I contact if I have additional questions with respect to this Disclosure Statement or the Second Amended Plan?

If you have any questions regarding this Disclosure Statement or the Second Amended Plan, please contact the Notice and Solicitation Agent, via one of the following methods:

By electronic mail to: gwginfo@donlinrecano.com

By telephone (toll free) at: 1 (888) 508-2507.

If sent by regular mail, send to:

Donlin, Recano & Company, Inc.
Re: GWGH Holdings, Inc., et al.
P.O. Box 199043
Blythebourne Station
Brooklyn, NY 11219

If sent by Overnight Courier or Hand Delivery, send to:

Donlin, Recano & Company, Inc.
Re: GWG Holdings, Inc., et al.
6201 15th Avenue
Brooklyn, NY 11219

Copies of the Second Amended Plan, this Disclosure Statement, and any other publicly filed documents in the Chapter 11 Cases are available upon written request to the Notice and Solicitation Agent at the address above or by downloading the exhibits and documents from the website of the Notice and Solicitation Agent at <https://www.donlinrecano.com/Clients/gwg/Index> (free of charge) or the Bankruptcy Court's website at <http://ecf.txsb.uscourts.gov> (for a fee).

Q. Do the Debtors recommend voting in favor of the Second Amended Plan?

Yes, the Debtors recommend that Holders of Claims and Interests vote in favor of the Second Amended Plan. The Debtors believe that the Second Amended Plan provides for a larger distribution to the Debtors' creditors than would otherwise result from any other available alternative. The Debtors believe that the Second Amended Plan is in the best interest of all Holders of Claims or Interests, and that any other alternatives (to the extent they exist) fail to realize or recognize the value inherent under the Second Amended Plan.

R. Does the Bondholder Committee recommend that Bondholders vote in favor of the Second Amended Plan?

Yes, the Bondholder Committee recommends that Bondholders vote in favor of the Second Amended Plan. As explained in this Disclosure Statement and the Bondholder Summary, the Second Amended Plan provides for the creation of two trusts: (i) the Wind Down Trust and (ii) the Litigation Trust.

The Wind Down Trust will liquidate and monetize the Policy Portfolio Equity Interests and the Debtors' interests in Beneficient and FOXO, and hold reversionary and beneficial interests in the Litigation Trust. On the Effective Date, the Bondholders will receive the senior most beneficial interests in the Wind Down Trust in an amount equal to the Bondholders' prepetition unpaid principal and interest.

The Litigation Trust will hold, for pursuit and prosecution, all Retained Causes of Action, including but not limited to Estate claims and causes of action against entities that are Non-Released Parties (including, without limitation, (i) Bradley K. Heppner, Thomas O. Hicks, Bruce W. Schnitzer, Dennis P. Lockhart, and Peter T. Cangany, (ii) HCLP Nominees, L.L.C., (iii) any entity associated with Beneficient, Heppner, or HCLP Nominees, L.L.C., (iv) any advisor or professional connected with Beneficient, (v) the Debtors' former directors and officers (including, without limitation, Murray Holland and Timothy Evans), in their capacity as such, and (vi) the Debtors' prepetition legal counsel with respect to any prepetition advice to the Debtors and/or any former directors or officers of the Debtors relating to prepetition transactions between the Debtors and Beneficient). All proceeds recognized by the Litigation Trust will be distributed by the Wind Down Trustee in accordance with the waterfall set forth in the Second Amended Plan.

Although the Debtors retain the right to settle certain claims and causes of action against Beneficient and the Beneficient Parties in advance of Confirmation of the Second Amended Plan, importantly, the Bondholder Committee retains any and all rights to object to any such settlement if the Bondholder Committee determines that any such settlement is not in the best interests of the Bondholders.

If Bondholders have any questions regarding the Second Amended Plan, the Disclosure Statement, the Voting Procedures, your Ballot or any other matters, Bondholders may contact the Bondholder Committee’s counsel by email at GWGBondholders@akingump.com, online at <https://www.donlinrecano.com/GWGBondholders> or otherwise by contacting counsel to the Bondholder Committee via the contact information contained on that website.

S. Does the Ad Hoc Broker/Dealer Committee recommend voting in favor of the Second Amended Plan?

Yes, the Ad Hoc Broker/Dealer Committee recommends that Holders of Claims and Interests vote in favor of the Second Amended Plan. The Ad Hoc Broker/Dealer Committee believes the Second Amended Plan constitutes the best opportunity for creditors, especially Bondholders, to receive the highest possible recovery on their claims. The Second Amended Plan contemplates the creation of both a “Wind Down Trust” and a “Litigation Trust.” The Ad Hoc Broker/Dealer Committee believes that the Wind Down Trust presents parties with the opportunity for substantial recovery on their claims and interests through the monetization and liquidation of the Debtors’ assets and economic interests, particularly through the retention of the Debtors’ interests in Beneficient. The Ad Hoc Broker/Dealer Committee believes that, should Beneficient consummate its contemplated merger with Avalon, the implied enterprise valuation of \$3.5 billion suggests a significant return on the Debtors’ investment, all for the benefit of the Debtors’ creditors and equity interest holders. Separately, the Litigation Trust will retain all non-released causes of action currently held by the Debtors’ Estates which, in the event the Debtors do not settle the associated claims against Beneficient, may include such claims. The Litigation Trustee will be empowered to take whatever action is in the best interest of creditors, including the litigation or the compromise and settlement of all causes of action. The Second Amended Plan therefore maximizes all available assets for the benefit of creditors and parties in interest.⁴¹

IV. THE COMPANY’S CORPORATE HISTORY, STRUCTURE, AND PREPETITION BUSINESS OVERVIEW

A. The Company’s Corporate History and Business Overview

The Company is a financial services firm that has historically specialized in life settlement assets. Life settlement assets are whole life insurance policies (with only a minority being variable) acquired directly or indirectly from the insured person or other owners of a life insurance policy.

⁴¹ In connection with the Ad Hoc Broker/Dealer Committee’s support of the Second Amended Plan, the Ad Hoc Broker/Dealer Committee (through the members of the Ad Hoc Broker/Dealer Committee and/or the Debtors) are distributing a letter to the clients of the members of the Ad Hoc Broker/Dealer Committee supporting confirmation of the Second Amended Plan and encouraging and recommending Bondholders and other stakeholders to vote to accept the Second Amended Plan.

The Company also has interests in Beneficient, which endeavors to provide liquidity solutions to holders of alternative assets (assets that are not traditional stocks, bonds or cash equivalents), and FOXO, an epigenetics technology company developing products for the life insurance industry. The Company's business was originally organized in February of 2006, with GWGH formed as the ultimate parent holding company in March of 2008. GWGH is a corporation organized under the laws of the state of Delaware. In September of 2014, GWGH consummated an initial public offering of its common stock on the Nasdaq stock market. GWGH's stock was delisted from Nasdaq in May 2022 as a result of the filing of the Chapter 11 Cases of the Initial Debtors.



Initially, the Company's business model centered on the acquisition of life settlement assets. Over the course of several years, GWGH acquired, through its subsidiaries DLP IV and DLP VI, the Policy Portfolio consisting of approximately 1,405 intermediate-duration and long-duration Policies. The majority of the Policies were acquired through secondary-market purchase transactions with insureds between 2006 and 2018. As of April 14, 2023, 847 of these Policies are still active, and of this amount, 553 Policies are held at DLP IV, and 294 Policies are held at DLP VI. As of April 14, 2023, the approximate face amount of the Policy Portfolio was \$1.6 billion. This life settlement business was conducted through GWGH's wholly-owned subsidiary, GWG Life, and GWG Life's wholly-owned direct and indirect subsidiaries, DLP IV, DLP VI, and DLP VI Holdings. DLP VI Holdings is the sole member of DLP VI. The DLP Entities were structured to be bankruptcy remote entities that are separate and distinct from their ultimate parents. Following the vote and approval of their respective boards, as further described in Article VI.C.7 of this Disclosure Statement, the DLP Entities each filed petitions for bankruptcy under Chapter 11 of the Bankruptcy Code on October 31, 2022. However, notwithstanding such bankruptcy filings, the assets and liabilities of the DLP Entities remain separate and distinct from the assets of GWGH and GWG Life.⁴²

A copy of the Company's relevant prepetition organizational chart, including certain non-debtor affiliates discussed herein, is included below.

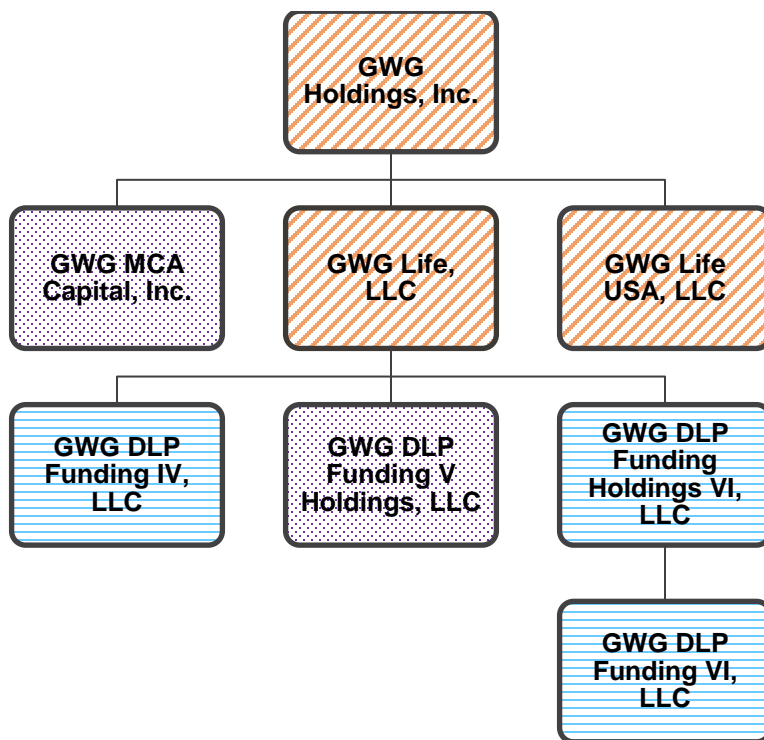
⁴² With the filing of the DLP Chapter 11 Cases, the Debtors filed the Debtors' Emergency Motion for an Order (I) Directing Joint Administration of the DLP Chapter 11 Cases Together with the Initial Chapter 11 Cases and (II) Applying Certain Orders in the Initial Chapter 11 Cases to the DLP Chapter 11 Cases [Docket No. 962] (the "DLP Entities' Joint Administration Motion") seeking to have the DLP Entities' Estates jointly administered with these Chapter 11 Cases. This motion sought procedural joint administration and not the substantive consolidation of the assets and liabilities of the DLP Entities with those of the Initial Debtors and the application to the DLP Debtors of certain orders previously entered in the Chapter 11 Cases. On October 31, 2022, the Bankruptcy Court approved joint administration of the Chapter 11 Cases. [Docket No. 970].



Organizational Chart Key

-  Non-Debtor Affiliates
-  DLP Debtors
-  Initial Debtors

Beginning in 2018, the Company entered into a distinct but related line of business through owning interests in and making loans to Beneficient, which markets an array of liquidity and trust administration products and services to owners of alternative assets.

The Company's life settlement business and interests in Beneficient and FOXO are described in further detail below.

1. Life Settlement Business

The secondary life settlement business model is to earn yields from the Policy Portfolio, net of premium payments and other costs. The majority of the Policies were acquired through secondary-market purchase transactions directly and indirectly from insureds between 2006 and 2018. Life settlements involve the sale of a life insurance policy to a third party at a discount to the face value, but at a price that is typically higher than the cash surrender value of a whole life or universal life insurance policy. The buyer of a life insurance policy, in this case DLP IV or DLP

VI,⁴³ becomes the policy's beneficial owner and takes responsibility for making the premium payments and the cost of servicing the policy in exchange for becoming the recipient of the death benefit when the insured passes away (referred to in the industry as a "maturity" of the underlying life insurance policy). Over time, the value of Policies increases as maturities are likely to occur more frequently with the aging of the insured and fewer premium payments need to be made relative to the life of the insured. Valuation models discount the expected maturity amounts to the current date. The shorter the term of the discount (i.e., the sooner the maturities are expected to occur), the more valuable the Policy Portfolio becomes.

When life insurance policies are purchased via numerous life settlements and pooled, such as those owned by the DLP Entities, the owner must have significant capital available to pay the premiums and servicing costs necessary to maintain the underlying life insurance policies. When Policies are acquired, the expected time before payout on the Policy can be 10, 20, or even 30 years. The capital required to maintain a portfolio of life insurance policies is typically obtained in one of two ways: (i) cash flow from operations, generally associated with proceeds from policies that have matured—in other words—policies that have paid out their death benefits because of a maturity or (ii) from monies raised from the capital markets. With respect to the first option, a purchaser of policies via a life settlement must be able to predict how long before a maturity occurs—a prediction that can never be done with absolute certainty, but can be predicted with actuarial modeling (assuming that a sufficient number of policies are owned), thus enabling an owner to project revenues for the entire portfolio. With respect to the second option, the purchaser must have consistent and predictable access to the capital markets, which access may be subject to external factors largely outside of the purchaser's control. During the first ten years of building the Policy Portfolio, the Company relied on access to the capital markets through the sale of Bonds for cash necessary to pay premiums and expenses.

In addition to the cash required to pay monthly insurance premiums, a business managing a portfolio of life settlement assets also has operating costs and must make payments of interest and principal on debt, if applicable. In 2023, the average estimated monthly premium payments required to maintain the Policy Portfolio is expected to be approximately \$6.5 million. If premiums are not paid, a Policy can enter a grace period and ultimately lapse, resulting in an immediate total loss of death benefits upon the death of an insured. Unlike other types of assets, the Policy does not depreciate by a certain percentage if it is not maintained; rather, whether the Policy retains value is a binary outcome—either the Policy is properly serviced and retains its full value or the Policy lapses and loses *all* value. Therefore, the timely payment of premiums and servicing costs is critical to ensure that every Policy, and the Policy Portfolio as a whole, is not rendered valueless.

The DLP Entities have historically made monthly premium payments from both collections on Policy maturities after the death of an insured and from proceeds of Bonds and other financing sold or incurred by GWGH and GWG Life.

⁴³ Certain Policies were initially purchased by an Initial Debtor and then transferred to DLP IV or DLP VI, as applicable.

2. Beneficient

(a) Overview of Beneficient's Business

Beneficient is a financial services holding company that (together with its subsidiaries) endeavors to provide what it describes as simple, rapid, and cost-effective liquidity solutions and related trust, custody and administrative services to participants in the alternative asset industry and owns certain alternative assets in connection therewith. It is headquartered in Dallas, Texas, and was a consolidated subsidiary of GWGH prior to the Beneficient Separation Transactions (as defined herein). For more information regarding Beneficient's business, Holders of Claims and Interests are encouraged to review the Ben S-4 that was filed with the SEC, including the section titled "Business of Beneficient".

(b) Certain prepetition transactions with Beneficient⁴⁴

As noted above, the Company historically specialized in life settlements, which is a method of providing liquidity solutions to owners of generally illiquid assets, in such case, life insurance policies. During the period from 2018 to 2021, the Company engaged in a series of transactions with Beneficient which purported to give the Company exposure to alternative assets, another type of asset that is generally illiquid. The Company's transactions in which it invested in Beneficient prior to the Initial Petition Date are further described in detail below.

The Exchange Transaction

On January 12, 2018, GWGH and GWG Life entered into a *Master Exchange Agreement* (the "Master Exchange Agreement") with Ben LP and certain other parties pursuant to which the Company agreed to a series of strategic exchanges of assets (the "Exchange Transaction"). The purported purpose of the Exchange Transactions was to further the Company's relationship with Beneficient. A significant portion (but not all) of the alternative assets that were purchased through the Exchange Transaction constituted limited partnership interests originally held by Paul Capital.

To facilitate the Exchange Transaction, Murray Holland, who served as Ben's informal investment banker in the deal, established a series of trusts in 2017 (the "Seller Trusts"),⁴⁵ which served as intermediary vehicles to hold assets transferred in connection with the Master Exchange Agreement, including the Seller Trust L Bonds.

The Exchange Transaction was completed via a series of two closings, with the first occurring on August 10, 2018 and the second on December 28, 2018. On the August 10, 2018 closing, Ben LP, as borrower, entered into a *Commercial Loan Agreement* (the "Commercial Loan Agreement") with GWG Life, as lender, pursuant to which GWG Life made a loan to Ben LP.

⁴⁴ The below does not purport to be a complete description of all transactions with Beneficient and its affiliates and related parties, and the foregoing shall not be deemed to prejudice or waive in any respect any claims or causes of action that may be pursued with respect thereto. The Bondholder Committee believes that the below described transactions, and potentially other transactions, give rise to valuable and viable claims and causes of action, and the Bondholder Committee shall not be deemed to adopt or support any of the descriptions contained herein.

⁴⁵ MHT Financial, L.L.C., an entity affiliated with the Debtors' former Chief Executive Officer Murray T. Holland, is the sole beneficiary of each Seller Trust. The Seller Trusts are further described in Article VI.B.3 of this Disclosure Statement.

Upon the completion of the Exchange Transaction, the principal amount of the loan outstanding under the Commercial Loan Agreement was approximately \$192.5 million. The loan under the Commercial Loan Agreement had a maturity of August 9, 2023, which maturity could potentially be extended to August 9, 2028 or August 9, 2033, provided that certain conditions were met.

The Exchange Transaction was completed on December 28, 2018. As a result of the Exchange Transaction, a number of securities were exchanged between the parties, the majority of which was non-cash, including the following securities as of the December 28, 2018 closing: (i) the Seller Trusts acquired Bonds due 2023 in the aggregate principal amount of \$366.9 million (the “Seller Trust L Bonds”); (ii) the Seller Trusts acquired 27,013,516 shares of GWGH’s common stock, which was 83% of the outstanding common stock at that time; (iii) GWGH acquired 40,505,279 Ben LP common units; and (iv) GWGH acquired the option, pursuant to an *Option Agreement* (the “Ben Option Agreement”) to obtain additional Ben LP common units or other property that would be received by a holder of Preferred Series A Subclass 1 Unit Accounts of BCH. BCH is a Delaware limited partnership of which Ben LP owns all of the outstanding common units and acts as its general partner. In addition, GWGH used proceeds that resulted from the Exchange Transaction to issue a \$25.7 million special dividend to its shareholders, including Jon R. Sabes (former Chief Executive Officer and director of GWGH and founder and former Chief Executive Officer of FOXO) and Steven F. Sabes (former Executive Vice President and director of GWGH).

The Seller Trusts now hold approximately \$272 million of the \$367 million outstanding Seller Trust L Bonds.⁴⁶ Following the Exchange Transaction, on April 26, 2019 David De Weese, a principal at Paul Capital and existing Board Member of Ben, was appointed to GWG’s Board of Directors and served as a Board Member through 2022.

The Seller Trust L Bonds were issued pursuant to that certain *Supplemental Indenture to Amended and Restated Indenture*, dated as of August 10, 2018 (the “2018 Supplemental Indenture”) with GWGH, GWG Life and Bank of Utah as indenture trustee.

The Bondholder Committee believes that there may be viable challenges, including challenges for subordination or recharacterization of the Seller Trust L Bonds, which LBM disputes. These potential challenges are proposed to be settled pursuant to the LBM Settlement. However, in the event LBM exercises its right to withdraw from the LBM Settlement, the Litigation Trust will have the right to pursue any such challenges. GWGH exercised the Ben Option Agreement, which exercise was effective August 11, 2020. Upon such exercise, GWGH received \$57.5 million of Ben LP common units at a price per unit equal to \$12.50.

Promissory Note with certain LiquidTrusts

On April 15, 2019, Jon R. Sabes (former Chief Executive Officer and director of GWG and founder and former Chief Executive Officer of FOXO) and Steven F. Sabes (former Executive Vice President and director of GWGH) entered into that certain Purchase and Contribution Agreement (the “Purchase and Contribution Agreement”) with, among others, Ben, under which Messrs. Sabes and Sabes (1) transferred all of their directly or indirectly held shares in GWGH’s

⁴⁶ Approximately \$95 million of Seller Trust L Bonds were transferred to the Custody Trusts in September 2020 in exchange for alternative assets purportedly valued at \$94.3 million.

outstanding common stock to BCC and AltiVerse Capital Markets LLC (“AltiVerse”) in exchange for \$25 million in cash (the “Sabes Buyout Obligation”) and (2) resigned from substantially all of their officer positions with the Company. Under the Purchase and Contribution Agreement, Beneficient also received the right to appoint the members of the board of GWGH and utilized that right.

On May 31, 2019, certain trusts affiliated with Beneficient (the “LiquidTrusts”) executed a *Promissory Note* (the “LiquidTrust Promissory Note”) with GWG Life for a principal amount of \$65 million, maturing on June 30, 2023. GWG made an initial \$50 million advance on the LiquidTrust Promissory Note on June 3, 2019 and funded the remaining \$15 million no later than November 27, 2019. Shortly thereafter, the Company approved a limited waiver under the Purchase and Contribution Agreement that would allow Beneficient to use \$25 million of the proceeds from the LiquidTrust Promissory Note to satisfy the Sabes Buyout Obligation.

On September 30, 2020, GWGH, GWG Life and the LiquidTrusts agreed to accept in full satisfaction of the LiquidTrust Promissory Note and any related accrued interest a \$75 million Preferred Series C Subclass 1 Unit Account of BCH that Ben LP issued to the LiquidTrusts.

Purchase of Additional Beneficient Equity

On June 12, 2019, GWGH purchased 1,000,000 limited partnership units in Ben LP from Essex Woodlands Health Venture Fund IV LP and Essex Woodlands Health Venture Fund VI LP at a price of \$10 per limited partnership unit for a total purchase price of \$10 million (the “June 2019 Acquisition”). The \$10 million purchase price also satisfied certain of Beneficient’s purported obligations to the foregoing Essex entities.

Investment Agreement and UPA

On December 31, 2019, GWGH, Ben LP, BCH, and Beneficient Management, L.L.C. (“Beneficient Management”) entered into a *Preferred Series A Unit Account and Common Investment Agreement* (the “Investment Agreement”). Pursuant to the Investment Agreement, GWGH transferred \$79 million to Ben LP to acquire 666,667 Ben LP common units and a Preferred Series A Subclass 1 Unit Account of BCH (the “2019 Capital Contribution”). In connection with the Investment Agreement, GWGH, which as part of the April 15, 2019 transaction had its board appointed by Beneficient, obtained the right to appoint a majority of the board of directors of Beneficient Management, which is the general partner of Ben LP. As a result, GWGH obtained control of Ben LP, resulting in the consolidation of the two corporate groups for accounting and financial reporting purposes.

On July 15, 2020, GWGH entered into a *Preferred Series C Unit Purchase Agreement* (“UPA”) with Ben LP and BCH. During the years ended December 31, 2021 and December 31, 2020, GWGH provided Beneficient with \$14.8 million and \$130.2 million in capital in exchange for Preferred Series C of BCH pursuant to the UPA (collectively, the “2020 and 2021 Capital”).

Contributions”). A portion of the funds provided by GWGH were used to pay back indebtedness incurred by HCLP Nominees and other entities.

Beneficient separation transactions and subsequent developments

On August 13, 2021, GWGH, Ben LP and BCH entered into a non-binding term sheet pursuant to which the companies agreed to engage in a series of transactions that would ultimately separate Beneficient and the Company.

These transactions (the “Beneficient Separation Transactions”) were effective as of November 29, 2021. Specifically, on November 12, 2021, the GWGH and Ben Management boards approved amendments to the organizational documents of Ben LP, BCH and Ben Management. The centerpiece of the Beneficient Separation Transactions was GWGH relinquishing its ability to appoint the majority of the board of directors of Ben Management, Ben LP’s general partner, via amendment to Ben Management’s limited liability company agreement. GWGH also approved the creation of securities that Ben LP would issue in connection with capital raising activities and product offerings and the conversion of GWGH’s capital account balance in Preferred Series A Subclass 1 Unit Accounts in BCH to Preferred Series B Subclass 2 Unit Accounts in Ben LP. Finally, on November 26, 2021, GWGH and Ben LP entered into a payoff letter for the Commercial Loan Agreement (described above) pursuant to which Ben LP repaid the entire outstanding principal balance of the Commercial Loan Agreement of \$202.3 million plus accrued interest of \$5.8 million by issuing GWG Life 19,250,795 Ben LP common units.

On December 31, 2021, one of Ben LP’s subsidiaries, Beneficient Fiduciary Financial, L.L.C. (“BFF”) obtained a license to operate as a Kansas Technology Enabled Fiduciary Financial Institution (“TEFFI”).

As discussed in further detail in Article VII.3 of this Disclosure Statement, the potential Causes of Action arising from or relating to each of the prepetition transactions with Beneficient described above, among other transactions, are the subject of the Independent Investigation (as defined herein) conducted by the Investigations Committee.

As discussed in further detail in Article VI.H.3 of this Disclosure Statement, the Bondholder Committee has sought the Bankruptcy Court’s approval for standing to prosecute Causes of Action on behalf of and for the benefit of the Debtors’ Estates arising from, among other things, the prepetition transactions with Beneficient described above.

(c) *Shared Services Agreement*

GWGH and Ben LP entered into a *Shared Services Agreement* on May 27, 2020 (the “Shared Services Agreement”). Pursuant to the Shared Services Agreement, Beneficient agreed to provide certain services to the Company, including access to certain Beneficient employees who then acted at the direction of the Company’s senior management, with service fees paid on a quarterly basis in accordance with a certain cost allocation methodology. Specifically, Beneficient provides services to the Company in the following categories: Accounting & Finance; General & Administrative; Human Resources; Sales & Marketing; Underwriting & Risk Management; Information Technology; Legal; and any additional services as mutually agreed upon in writing (the “Shared Services”). Pursuant to the Shared Services Agreement, the Company compensated

Beneficiary for the Shared Services by paying a quarterly fee (the “Service Fee”). Pursuant to the Shared Services Agreement, the Service Fee is computed by Beneficiary at the end of each calendar quarter and is payable by the Company, subject to audit rights, within 30 days after the end of each such quarter.

The treatment of the Shared Services Agreement under the Second Amended Plan is described in Article VI.G.2 of this Disclosure Statement.

(d) Certain postpetition developments—the Avalon Business Combination

Following the Initial Petition Date, on September 21, 2022, Beneficiary announced that it had entered into a business combination agreement with Avalon, which is a special purpose acquisition company (SPAC). The business combination announcement by Beneficiary stated that the combined companies would have an implied enterprise value of \$3.5 billion, which includes approximately \$200 million in proceeds from Avalon’s cash in trust (assuming no public stockholders in Avalon exercise their redemption rights in connection with the consummation of the business combination). This valuation, conducted by Avalon, ascribes a value of \$1.4 billion to the Company’s interests in Beneficiary, assuming that a purchaser could be found for such interests. The Bondholder Committee notes, however, that this value has yet to be proven by any other market evidence. The Bondholder Committee does not adopt this valuation for any purposes.

The Avalon Business Combination is scheduled to close in the first half of 2023, subject to satisfaction or waiver of closing conditions in the business combination agreement. On April 18, 2023, Avalon and Ben LP executed an amendment to the business combination agreement removing the requirement to obtain the GWGH’s consent as a condition precedent to closing the Avalon Business Combination. The Debtors understand that Beneficiary’s position is that, because Beneficiary and Avalon removed the requirement to obtain GWGH’s consent from the business combination agreement, Beneficiary and Avalon no longer need the Company’s consent to consummate the Avalon Business Combination. The Company continues to believe that, whether pursuant to the applicable agreements and/or the Bankruptcy Code, its consent is required for Beneficiary and Avalon to consummate the Avalon Business Combination.

On each of January 5, 2023 and April 5, 2023, Avalon, issued a press release announcing that Ben LP had deposited \$2,070,000 in cash (\$4,140,000 in the aggregate) into Avalon’s trust account for Avalon’s public stockholders, representing \$0.10 per public share (\$.20 per public share in the aggregate), which enabled Avalon to extend the period of time it has to consummate its initial business combination by a total of six months from January 8, 2023 to July 8, 2023 (the “Extension”). Any further extensions will require Avalon’s stockholders to approve an amendment to its certificate of incorporation. If Avalon decides to seek such an amendment, it will be required make an offer to redeem its outstanding shares of Class A common stock with funds from the trust account in connection with adopting such amendment.

If the Avalon Business Combination is consummated, the combined company is expected to be listed on the Nasdaq stock market. On January 11, 2023, Avalon received a notice from the Listing Qualifications Department of Nasdaq stating that Avalon failed to hold an annual meeting of stockholders within 12 months after its fiscal year ended December 31, 2021, as required by

Nasdaq Listing Rule 5620(a). In accordance with Nasdaq Listing Rule 5810(c)(2)(G), Avalon had 45 calendar days (or until February 27, 2023) to submit a plan to regain compliance and, if Nasdaq accepts the plan, Nasdaq may grant Avalon up to 180 calendar days from its fiscal year end, or until June 29, 2023, to regain compliance. Avalon has not announced whether Nasdaq has accepted its plan to regain compliance.

Pursuant to Article IV.U of the Second Amended Plan, prior to the Effective Date, any consents necessary in connection with approval of a special purpose acquisition company (SPAC) transaction of Beneficient shall require the consent of the Debtors and the Special Committee and shall be subject to Bankruptcy Court approval. For the avoidance of doubt, the required Bankruptcy Court approval may be contained in an order approving a proposed settlement with Beneficient. After the Effective Date, any such consents shall require the consent of the Wind Down Trustee and shall be subject to Bankruptcy Court approval. For the avoidance of doubt, after the Effective Date, such consent (and request for Bankruptcy Court approval by the Wind Down Trustee) may not include any releases or compromises of any Retained Causes of Action that are transferred to the Litigation Trust on the Effective Date without the consent of the Litigation Trustee.

3. FOXO

(a) *Overview of FOXO*

As of the Initial Petition Date, the Company held a non-controlling interest in FOXO which, through its wholly-owned subsidiaries FOXO Labs Inc. (“FOXO Labs”) and FOXO Life LLC (“FOXO Life”), seeks to commercialize epigenetic technology for the longevity industry and offer life insurance directly to customers utilizing epigenetic technology. FOXO Labs was formed to commercialize epigenetic technology for the longevity industry. FOXO Life seeks to offer life insurance directly to customers utilizing epigenetic technology. On February 24, 2022, FOXO entered into a merger agreement (the “FOXO Merger”) with Delwinds, a special purpose acquisition company. In connection with announcing the FOXO Merger, FOXO also announced the combined company had an estimated enterprise value of \$369 million and that it anticipated becoming listed on the New York Stock Exchange.

(b) *Postpetition developments – merger with Delwinds*

The FOXO Merger was consummated on September 16, 2022. The combined company operates under the name FOXO Technologies, Inc. and common stock in the combined company trades on the NYSE American under the symbol FOXO. As of April 14, 2023, the combined company had a market capitalization of approximately \$19.467 million, which implies that the Debtors’ interests in FOXO have a value of \$3,266,000.

Since FOXO’s incorporation but before the FOXO Merger, the Company’s equity ownership of FOXO was diluted from 80% to 23% due to several significant events over which the Company did not have veto rights, which included FOXO’s issuance of (a) convertible debentures; (b) stock options/restricted stock to employees; (c) equity to Bespoke Capital Partners in exchange for consulting services in connection with the FOXO Merger; and (d) equity to the lead institutional investor in one of the convertible debenture placements. After significant due

diligence, the Company concluded the FOXO Merger itself further diluted their full pre-FOXO Merger ownership, resulting in a dilution of the Company’s ownership from 23% to 13%, or 4.6 million Class A shares. Moreover, the Delwinds merger proxy discloses that Delwinds entered into a voting agreement with certain FOXO stockholders that provided sufficient votes to approve the FOXO Merger without the Company’s vote.

In connection with the FOXO Merger, FOXO has requested that the Company execute a *Letter of Transmittal to Surrender Shares of Common Stock of FOXO Technologies Inc.* (the “FOXO Letter”) in order for the Company to receive its pro rata share of consideration from the FOXO Merger. The initial draft of the FOXO Letter included a release of Delwinds and FOXO. Following discussions with FOXO’s counsel, FOXO has agreed to remove the release from the FOXO Letter.

B. The Company’s Prepetition Capital Structure

1. Prepetition Equity Holdings

As of the Initial Petition Date, GWGH had issued and outstanding common shares, Series 1 Preferred Interests, and Series 2 Preferred Interests as summarized below:

Equity Interest	Total Shares Outstanding
Common Equity	33,102,273.250 (\$2.04/share trading price) ⁴⁷
Redeemable Preferred Stock	41,681 (\$42,662,169 liquidation preference)
Series 2 Redeemable Preferred Stock	86,707 (\$88,140,766 liquidation preference)

Beneficient or parties related to Beneficient own approximately 12% of GWGH’s common stock. As described above, the Seller Trusts acquired approximately 83% of the common stock of GWGH pursuant to the Exchange Transaction (as of the Initial Petition Date, such portion would constitute 78% of GWGH’s common stock). Thereafter, certain common law trusts (the “Custody Trusts”)⁴⁸ subsequently acquired from the Seller Trusts a portion of GWGH’s common stock representing 30% of GWGH’s common stock and, as described above, have agreed pursuant to the Stockholders Agreement to vote their shares in the same proportion as other stockholders vote. Thus, the Seller Trusts control the vote of GWGH’s common stock, but do not control Beneficient, and the parties who ultimately benefit from the economics of the GWGH common stock held by the Seller Trusts and Custody Trusts are clients of Beneficient who are otherwise unaffiliated with GWGH or Beneficient. The Seller Trusts, the above-referenced Custody Trusts, Beneficient, and former GWGH board members collectively own approximately 90% of the outstanding GWGH common stock (or approximately 29.8 million shares). Approximately 10% (or approximately 3.3

⁴⁷ Share trading price as of April 19, 2022. The shares have since been delisted from the Nasdaq stock market.

⁴⁸ The Custody Trusts are further described in Article VI.B.3 of this Disclosure Statement.

million shares) is owned by primarily independent stockholders. The current GWGH common stock ownership can be summarized as follows:

Stockholder	Percentage of GWGH Common Stock Ownership
Beneficient or parties related to Beneficient	12%
Seller Trusts	48%
Custody Trusts	30%
Other stockholders	Approx. 10%

GWGH made two public offerings of preferred stock in 2015 and 2017, raising \$99 million and \$150 million, respectively. Series 1 Preferred Interests were issued to investors in a public offering of up to 100,000 shares of Series 1 Preferred Interests at \$1,000 per share that was declared effective on November 30, 2015. Holders of the Series 1 Preferred Interests are entitled to cumulative dividends at the rate of 7% per annum. Dividends on the Series 1 Preferred Interests are recorded as a reduction to additional paid-in capital, if any, then to the outstanding balance of the preferred stock if additional paid-in capital has been exhausted. In certain circumstances, additional shares of Series 1 Preferred Interests may be issued in lieu of cash dividends. The Series 1 Preferred Interests rank senior to GWGH's common stock and pari passu with the Series 2 Preferred Interests (collectively, with the Series 1 Preferred Interests, the "Existing Preferred Interests"), and entitle its holders to a liquidation preference equal to the stated value per share (i.e., \$1,000) plus accrued and unpaid dividends. On February 14, 2017, GWGH's public offering of up to 150,000 shares of Series 2 Preferred Interests at \$1,000 per share was declared effective. The terms of the Series 2 Preferred Interests are largely consistent with those of the Series 1 Preferred Interests. In the first quarter of 2022, GWGH paid a dividend on the Existing Preferred Interests in kind, resulting in an increase in the stated value per share of the securities of approximately \$5.83.

2. Prepetition Debt

As of the Initial Petition Date, the Company's prepetition capital structure included approximately \$2,075,470,254 in funded debt, as summarized below:

Indebtedness	Funded Debt
Bonds	\$1,672,852,358
DLP IV Loan Facility	\$271,213,144
DLP VI Loan Facility	\$111,126,464
Total Secured Debt	\$2,055,191,966
Unsecured Debt	\$20,278,288
Total Funded Debt	\$2,075,470,254

(a) *Bond Debt*

GWGH issued Bonds pursuant to the (i) *Amended and Restated Indenture* dated as of October 23, 2017, by and between GWGH, as issuer and obligor, GWG Life, as guarantor, and Bank of Utah as indenture trustee (the “A&R Indenture”), (ii) *Supplemental Indenture* dated as of December 31, 2020 (the “2020 Supplemental Indenture”), by and between GWGH, as guarantor, GWG Life, as issuer and obligor, and Bank of Utah as indenture trustee (the “Liquidity Bonds”), and (iii) 2018 Supplemental Indenture (collectively with the A&R Indenture and 2020 Supplemental Indenture, the “Indenture”). Bonds issued under the A&R Indenture that do not constitute Liquidity Bonds or Seller Trust L Bonds are referred to herein for ease of reference as “Public L Bonds”. The A&R Indenture governs the terms of all of the issued Bonds except to the extent expressly provided in the Supplemental Indentures. The Bonds are secured by substantially all of the assets of GWGH and GWG Life pursuant to the *Amended and Restated Pledge and Security Agreement* among GWGH, GWG Life and Bank of Utah.⁴⁹

GWGH began publicly offering and selling the Public L Bonds through registered broker/dealers and registered investment advisers (the “Broker Dealers”) in January 2012 under various registration statements. On December 1, 2017, an additional public offering was declared effective permitting GWGH to sell up to \$1.0 billion in principal amount of Public L Bonds on a continuous basis until December 2020, and GWGH reached the maximum capacity permitted for that offering during the third quarter of 2020. On June 3, 2020, a registration statement relating to an additional public offering was declared effective permitting GWGH to sell up to \$2.0 billion in principal amount of Public L Bonds on a continuous basis through June 2023. As described in further detail below, GWGH suspended the offering of Public L Bonds prior to the Initial Petition Date, initially on April 16, 2021 as a result of GWGH’s delay in filing certain periodic reports with the SEC, and later in early 2022 as a result of the financial difficulties that precipitated the filing of the Chapter 11 Cases. As of the Initial Petition Date, there were approximately \$1.26 billion in Public L Bonds issued and outstanding.

The Liquidity Bonds were issued under the 2020 Supplemental Indenture which permitted the issuance of up to \$1.0 billion in aggregate principal amount. The Liquidity Bonds were offered

⁴⁹ On April 26, 2019, in connection with transactions related to the Purchase and Contribution Agreement described in Article IV.B.2.b of this Disclosure Statement, BCC and AltiVerse entered into that certain *Consent and Joinder to Amended and Restated Pledge and Security Agreement* (the “Consent and Joinder”), under which BCC and AltiVerse replaced Messrs. Sabes and Sabes as grantors under the security agreement collateralizing the Bonds. Per the Consent and Joinder, the shares of GWGH common stock BCC and AltiVerse acquired pursuant to the Purchase Agreement will continue to be pledged as collateral for the Bonds.

and sold to accredited investors in transactions that are exempt from the registration requirements of the Securities Act of 1933, as amended (the “Securities Act”), pursuant to Regulation D thereof. The Liquidity Bonds were issued as part of the Company’s strategy to expand its exposure to a portfolio of loans collateralized by cash flows from illiquid alternative assets. Holders of alternative assets would contribute their alternative assets to trusts established by Ben LP in exchange for Liquidity Bonds. The Liquidity Bonds bear interest rates determined at the time of issuance by the Company and the holders of the alternative assets being contributed and generally have a maturity of four years from issuance. As of the Initial Petition Date, there were approximately \$0.8 million (\$800,000) in Liquidity Bonds issued and outstanding.

As described above, the Seller Trust L Bonds were issued under the 2018 Supplemental Indenture in the amount of approximately \$366.9 million as part of the Exchange Transaction and remained outstanding as of the Initial Petition Date. The Seller Trust L Bonds mature on August 9, 2023.

As of the Initial Petition Date, there were approximately 27,700 direct and indirect active accounts held by Bondholders. Approximately 10,300 of such investments by Bondholders were purchased via subscription agreements directly with the Company, and approximately 17,400 of such investments by Bondholders were purchased through various securities intermediaries, such as The Depository Trust Company. The average individual Bondholder owns approximately \$45,000 worth of Bonds.

The Company used proceeds from the issuance of Bonds for various purposes, which, as disclosed in its public filings with the SEC, included: (i) servicing the Policy Portfolio (i.e., paying life insurance premiums and operating costs), (ii) paying required interest on the Bonds and other debt and repaying maturing Bonds, (iii) paying dividends and redemption amounts on the Company’s preferred stock, (iv) furthering its relationship with Beneficient, (v) operating expenses, and (vi) additional corporate purposes.

The Company’s Bond debt as of the Initial Petition Date is summarized in more detail below:

Breakdown of Bonds (Principal Only)	Funded Debt
Public L Bonds	\$1,258,856,830
Liquidity Bonds	\$803,440
Seller Trust L Bonds	\$366,891,940
<i>Total Bond Debt</i>	<i>\$1,626,552,210</i>

The Bonds are secured by substantially all of GWGH’s and GWG Life’s assets—which include (a) the equity interests in the DLP Debtors (who themselves own the Policy Portfolio) and (b) certain interests in Ben LP (including through GWG Life’s equity interest in GWG Life USA, LLC) and certain stock pledged by Beneficient Capital Company, L.L.C. (“BCC”), which was formerly a main operating subsidiary of Ben LP, but, as of December 31, 2020 no longer holds any assets, and AltVerse Capital Markets, L.L.C. (“AltVerse”), an entity with certain overlapping investors with Ben LP. The Bonds are completely and entirely subordinated (both as to lien and

payment) to secured debt held by the DLP Entities (including the new repaid DLP IV Facility and DLP VI Facility) and any future Senior Debt incurred by GWGH, including any debtor-in-possession financing. Additionally, the Bonds are *pari passu* in right of payment and in respect of collateral with other Bonds and senior in right of payment to all subordinated indebtedness of GWGH.⁵⁰

(b) *DLP IV and DLP VI Facilities*

On the DLP Petition Date, DLP IV was the borrower under that certain *Fifth Amended and Restated Loan and Security Agreement* (the “DLP IV Facility”) dated as of December 14, 2021, by and between DLP IV, as borrower, LNV Corporation (“LNV”), as lender, and CLMG Corp. (“CLMG”), as administrative agent (the “DLP IV Agent” and collectively with LNV, the “DLP IV Lender Parties”). LNV and CLMG are subsidiaries of Beal Bank. The DLP IV Facility had a scheduled maturity date of February 1, 2027, and the obligations thereunder were secured by a first priority lien on substantially all of DLP IV’s assets—*i.e.*, Policies with an approximate face amount as of the DLP Petition Date of \$1.27 billion held by DLP IV. As of the DLP Petition Date, approximately \$275 million in principal amount remained outstanding under the DLP IV Facility, in addition to interest and certain fees. On December 15, 2022, the DLP IV Facility was paid in full in connection with the Debtors’ entering into the Vida DIP Facility. Following the payoff of the DLP IV Facility, DLP IV does not have any additional creditors who are presently owed any material amounts.

On the DLP Petition Date, DLP VI was the borrower under that certain *Credit Agreement* (the “DLP VI Facility”) dated as of August 11, 2021, with DLP VI, as borrower, and National Founders LP, as the lender (collectively with the Secured Parties (as defined in the DLP VI Facility), the “DLP VI Lender Parties” and, together with the DLP IV Lender Parties, the “DLP Senior Secured Parties”) and administrative agent (“National Founders”). The DLP VI Facility had a scheduled maturity date of August 11, 2031, and the obligations thereunder were secured by a first priority lien on substantially all of DLP VI’s and DLP Funding VI’s assets—*i.e.*, Policies with an approximate face amount as of the DLP Petition Date of \$400.6 million held by DLP VI. As of the DLP Petition Date, approximately \$111.4 million in principal amount remained outstanding under the DLP VI Facility, in addition to interest and certain fees. On December 15, 2022, the DLP IV Facility was paid in full in connection with the Debtors’ entering into the Vida DIP Facility. Following the payoff of the DLP VI Facility, DLP VI does not have any additional creditors who are presently owed any material amounts.

(c) *Unsecured debt*

The Initial Debtors’ had approximately \$20,278,288 in unsecured debt as of the Initial Petition Date. This unsecured debt was incurred primarily in connection with maintaining and servicing the Policy Portfolio as well as through obligations owing on account of the Shared Services Agreement, vendor claims, and professional fee claims.

⁵⁰ See § 1.6 of the 2018 Supplement Indenture and §1.8 of the 2020 Supplemental Indenture.

V. EVENTS LEADING TO THE CHAPTER 11 FILINGS

A. The Company's Financial and Legal Challenges

1. SEC Investigation and Accounting Questions

On October 6, 2020, the Enforcement Division of the SEC served a subpoena on the Company in connection with an investigation, thus informing the Company of the existence of a non-public, fact-finding investigation into the Company (the "SEC Investigation").⁵¹ The initial and subsequent subpoenas have requested information related to the Company's securities, including the Bonds (and the marketing, selling, advertising, sellers, and purchasers of such), disclosures, and various accounting matters; information related to documents and statements referenced in GWGH's SEC filings, including consolidation, valuations, retained professionals and related communications; information related to GWGH's relationship and communications with Beneficient and certain other parties, including negotiations and agreements; and information related to firm-wide policies and practices generally. GWGH has cooperated with the SEC throughout the course of its investigation which is ongoing.

In February 2021, with the recommendation and concurrence of its prior auditor, Grant Thornton, LLP, the Company posed two accounting questions to the SEC's Office of Chief Accountant ("OCA"). The questions submitted to OCA were (1) whether the December 31, 2019 transaction reflected in the Investment Agreement and described in Article IV.B.2.b of this Disclosure Statement resulted in GWGH obtaining control of Ben LP (it was determined later by the Company that it did) and (2) whether Ben LP was required to consolidate the Custody Trusts (OCA took the position that it would object to Ben LP not consolidating the Custody Trusts). The Company's original expectation was that these two questions would take approximately three weeks to resolve, after which the Company would be able to timely issue its financial statements. However, the process took almost six months and, as a result, the Company was unable to timely file certain financial statements, pending resolution of those questions. As a result of the delay, GWGH suspended Bond sales on April 16, 2021. The consultation with OCA concluded on July 26, 2021. GWGH began selling Bonds again in December 2021 after Grant Thornton completed its audit work and GWGH filed its 2020 form 10-K and 2021 Form 10-Qs. During this period, the Company used approximately \$350 million of cash for operations, premiums on policies, interest on Bonds, maturities on Bonds, dividends on preferred stock and redemptions on preferred stock.

The suspension of Bond sales between April and December 2021 foreclosed access to public capital markets and severely constrained the Company's liquidity. The Company raised no capital from the sale of Bonds during this time yet still had approximately \$40 million per month in cash obligations for interest and principal on Bonds, premiums of the Policy Portfolio, operating expenses and dividends and redemptions of preferred stock. During this time period, the Company

⁵¹ In accordance with its usual practice, the SEC's communication included the following statement: "This investigation is a non-public, fact-finding inquiry. We are trying to determine whether there have been any violations of the federal securities laws. The investigation and the subpoena do not mean that we have concluded that you or anyone else has violated the law. Also, the investigation does not mean that we have a negative opinion of any person, entity or security."

elected to enter into the DLP VI Facility and other financings in order to obtain critical liquidity until Bond sales could be resumed.

When the Company indicated its intent to restart its Bond sales, the SEC notified many of the Broker Dealers that the SEC would issue subpoenas and document requests to individual Broker Dealers if they sold Bonds. Following that, Bond sales between December 2021 and January 10, 2022 were dramatically lower than anticipated and insufficient to cover the Company's upcoming payment obligations on the Bonds. On January 10, 2022, the Company learned of the dramatically lower bond sales. Knowing that Bond sales would not recover to the traditional levels that were necessary to continue paying interest and maturities on the outstanding Bonds, and not having sufficient liquidity without Bond sale proceeds to continue paying interest and maturities on the Bonds, GWGH defaulted on interest payments of approximately \$10.35 million and principal payments of approximately \$3.25 million due January 15, 2022. Subsequently, on February 14, 2022, GWGH announced in a Form 8-K securities filing that it would be unable to make principal and interest payments due and owing on the Bonds while the Company evaluated its restructuring options.

2. Bondholder Lawsuit (*Bayati, et. al v. GWG Holdings, Inc.*)

Almost immediately thereafter, on February 18, 2022, Shirin Bayati and Mojan Kamalvand, on behalf of themselves and a proposed class of similarly situated individuals, filed a complaint against GWGH and certain of its past and present directors and officers alleging violations of §§ 11, 12(a)(2), and 15 of the Securities Act of 1933. The case is titled *Bayati, et al. v. GWG Holdings, Inc., et al.*, bears case number 22-00410, and is pending before the United States District Court for the Northern District of Texas (the "Securities Litigation"). Principally, the plaintiffs allege that GWGH and its co-defendants violated the Securities Act by using funds invested by Bondholders for impermissible purposes (including in connection with the prepetition transactions with Beneficient described in Article IV.A.2.b), filing various misleading documents with the SEC since 2020, and failing to disclose to Bond investors certain investigations by the SEC that could have impacted their decision to invest in the Bonds.

As of the Initial Petition Date, the Securities Litigation was in the pleading stage. The Company denies all of the allegations set forth in the complaint and takes the position that its robust and fulsome securities filings expressly and specifically disclosed the intent that the Bond proceeds would be used for all purposes complained of in the Securities Litigation, including to pay interest on and refinance the principal of existing Bonds and to invest in Beneficient. Except as otherwise described in Article VI.H.1 hereof, the Securities Litigation has been stayed.

B. Defaults Under DLP IV Facility and DLP VI Facility; Amendments and Waivers

The Company's continued obligations and the provisions of the DLP IV Facility and DLP VI Facility caused additional constraints on the Company's liquidity prior to the Initial Petition Date. There is a significant delay (typically 60 days but sometimes longer) between when a Policy matures and when DLP IV or DLP VI, as applicable, can collect proceeds from that maturity. Further, proceeds received on account of maturities under a Policy are, pursuant to the terms of DLP IV's and DLP VI's prepetition secured credit facilities, deposited in certain bank accounts at

Wells Fargo Bank, N.A. (the “Controlled Accounts”) that are subject to certain account control agreements (the “Account Control Agreements”) for the benefit of the DLP Senior Secured Parties. By operation of the Account Control Agreements, the DLP Senior Secured Parties were entitled to sweep the respective Controlled Accounts for payment of principal, interest, premiums and fees prior to paying premiums or making other withdrawals. As of the Initial Petition Date, substantially all of the Company’s funds were held in the Controlled Accounts, access to which was restricted by the express provisions of the DLP IV Facility and DLP VI Facility.

1. DLP IV Facility

As discussed above, beginning in August of 2021, GWGH commenced negotiating and documenting the Beneficient Separation Transactions, which resulted in Beneficient ceasing to be a consolidated subsidiary of GWGH. LNV subsequently notified DLP IV that it believed the Beneficient Separation Transactions constituted a change of control default under its credit facility with DLP IV (the “CoC Default”).

In November of 2021, DLP IV and the DLP IV Lender Parties commenced negotiations whereby certain cash waterfall provisions and cash sweeping rights granted to LNV in connection with the DLP IV Facility would be waived in order to permit DLP IV to access approximately \$16,958,377.45 in LNV’s cash collateral in the Controlled Accounts. These negotiations led to an executed letter agreement (the “Letter Agreement”) that required numerous post-closing deliverables to be provided by DLP IV to the DLP IV Lender Parties, many requiring the cooperation of third parties. DLP IV did not timely provide the post-closing deliverables required by the Letter Agreement, which resulted in an event of default under the DLP IV Facility (the “Letter Agreement Default”).

As a result of the purported defaults (the CoC Default and Letter Agreement Default), the DLP Lender Parties determined that, among other available remedies, they had the right under the DLP IV Facility to accelerate the indebtedness due and owing thereunder. Additionally, the DLP IV Lender Parties determined that in connection with any acceleration, a \$92,573,481.87 yield maintenance fee would become due and owing. DLP IV requested a waiver of the CoC Default and Letter Agreement Default and a related advance from the DLP Lender Parties in order to, among other things, make certain premium payments due and owing on the Policies that secure the DLP IV Facility.

On November 15, 2021, in consideration for certain cash collateral being released, DLP IV assigned and granted to the DLP IV Agent, for the ratable benefit of the lenders under the DLP IV Facility, an irrevocable beneficial interest in a weighted average of three percent (3.0%) of the U.S. dollar death benefit payable under each pledged Policy under the DLP IV Facility (the “Residual Beneficial Interest”). Such assignment meant that, with respect to a maturity under an applicable pledged Policy after such date, the DLP IV Agent had its own claim with the subject carrier with respect to such residual death benefit, and an average of three percent (3.0%) of the death benefit then paid under any such pledged Policy would be paid directly to the DLP IV Agent.

On December 14, 2021, DLP IV and the DLP IV Lender Parties entered into an amended and restated credit agreement (as described above, the DLP IV Facility), whereby the CoC Default and Letter Agreement Default were waived and LNV made an additional advance of \$60,100,000,

to be used as follows: (i) \$20,000,000 paid in cash to DLP IV to lend to GWG Life pursuant to an intercompany promissory note; (ii) \$100,000 paid to CSG Investments as a structuring fee; and (iii) \$40,000,000 paid to LNV as a partial settlement of the \$92,573,481.87 that would otherwise have been due as a yield maintenance fee upon acceleration. In addition, LNV agreed to a downward adjustment of the interest rate going forward. Pursuant to the terms of the DLP IV Facility, the yield maintenance claim is payable upon the acceleration of the obligations owing thereunder, including an automatic acceleration that occurred as a result of DLP IV filing for Chapter 11 relief.

In that certain *First Amendment to Fifth Amended and Restated Loan and Security Agreement* dated as of February 25, 2022, LNV, as an accommodation, agreed to vary the terms of the DLP IV Facility to make advances on the loan to be used to pay premiums that came due in March and April 2022. After the Initial Petition Date, LNV continued to make accommodations that permitted DLP IV to pay premiums, including agreeing to certain amendments, as described further below.

2. DLP VI Facility

Under the DLP VI Facility, DLP VI was required to maintain Required Reserve Amounts (as defined in the DLP VI Facility) in its Reserve Account (as defined in the DLP VI Facility) for the benefit of the DLP VI Lender Parties, which are to be funded on certain remittance dates. DLP VI anticipated that it would not have sufficient Required Reserve Amounts in its Reserve Account as of the February 2022 remittance date and, as such, negotiated and entered into that certain *Waiver* with National Founders on February 24, 2022, (the “DLP VI February Waiver”). Under the DLP VI February Waiver, National Founders agreed to waive, for a limited period up through March 10, 2022, the February 2022 Reserve Account Deficiency (as defined in the DLP VI February Waiver). Subsequently, on March 10, 2022, DLP VI and National Founders entered into an additional waiver, that extended the aforementioned waiver period through March 15, 2022, with the referenced default subsequently having been cured prior to such March 15th date.

On March 31, 2022, DLP VI and National Founders entered into a *Waiver and Amendment to Credit Agreement* (the “First DLP VI Amendment”) to the existing DLP VI Facility. The First DLP VI Amendment waived an event of default under the DLP VI Facility that had resulted due to insufficient funds in a reserve account established under such credit agreement. The First DLP VI Amendment also provided for an additional advance by National Founders of \$4 million, of which \$1 million was an amendment fee payable to National Founders, with the \$3 million balance being available to the Company for the payment of professional fees and other expenses. The First DLP VI Amendment also provided that the prepayment premium payable under the DLP VI Facility would also be due and payable upon an acceleration of the loans under the DLP VI Facility (not just upon a prepayment), in exchange for certain conditions, including the DLP IV Lender’s agreement to provide certain debtor-in-possession financing to the Initial Debtors.

C. The Company’s Proactive Exploration of Strategic Alternatives

As a result of the significant liquidity issues described above, the Company engaged Mayer Brown LLP (“Mayer Brown”) as restructuring counsel in January 2022, FTI Consulting as financial advisor in January 2022, and PJT Partners (“PJT”) as investment banker in February

2022 in connection with identifying and evaluating restructuring alternatives, as well as available options to best conserve and maximize the value of the Company's assets for the benefit of its stakeholders. In connection with that process, PJT and the Company solicited bridge financing and debtor-in-possession financing proposals, ultimately selecting a debtor-in-possession financing proposal of National Founders and related parties, as described in further detail below. The Initial Debtors determined that it would be necessary to seek chapter 11 relief in order to address their liquidity issues and approve the debtor-in-possession financing proposal, and on April 20, 2022, the Initial Debtors filed voluntary petitions for relief under the Bankruptcy Code.

VI. MATERIAL DEVELOPMENTS AND ANTICIPATED EVENTS OF THE CHAPTER 11 CASES

A. First Day Pleadings and Other Procedural and Administrative Motions

On the Initial Petition Date, the Initial Debtors filed the Interim DIP Motion (as described below) and several other procedural and administrative motions (the "First Day Motions") intended to stabilize the Initial Debtors' business operations and facilitate the efficient administration of these Chapter 11 Cases. The Initial Debtors have continued in their possession of their property and have continued to operate and manage their business as debtors in possession pursuant to sections 1107(a) and 1108 of the Bankruptcy Code. No request has been made for the appointment of a trustee or examiner in these Chapter 11 Cases.

The First Day Motions sought authority to, among other things, obtain debtor-in-possession financing on an interim basis, reject burdensome executory contracts and unexpired leases, honor employee related wages and benefits obligations, and ensure the continuation of the Initial Debtors' surety program, insurance, cash management systems, and other business operations without interruption. A brief description of each of the First Day Motions is set forth below, and the evidence in support thereof is set forth in the *Declaration of Timothy Evans, Chief Financial Officer of GWG Holdings, Inc., in Support of Chapter 11 Petitions and First Day Motions* (the "First Day Declaration") [Docket No. 17], filed on the Initial Petition Date. The various First Day Motions included:

- Motion for Joint Administration. The Initial Debtors' Chapter 11 Cases sought joint administration for administrative purposes under Case No. 22-90032 with the case caption *In re GWG Holdings, Inc., et al.* [Docket No. 2].
- Motion to Pay Employee Compensation and Benefits. Pursuant to the Shared Services Agreement, a number of individuals perform services for the Company. By this motion, the Initial Debtors sought authority to pay compensation, withholding obligations, health and welfare program-related obligations, stock incentive plan-related obligations and non-management director compensation in the ordinary course of business, whether arising before or after the Initial Petition Date, including some amounts in excess of the \$15,150 priority cap mandated under the Bankruptcy Code. [Docket No. 4].
- Motion to Pay Critical Vendors. The Initial Debtors sought to pay prepetition claims of certain vendors that the Initial Debtors deemed critical to being able to

smoothly continue their operations postpetition. The motion requested up to \$125,000 on an interim basis and up to \$250,000 on a final basis. [Docket No. 5].

- Motion to Establish Trading Procedures of Common Stock. By this motion, the Initial Debtors sought to establish trading procedures for their common stock to preserve net operating losses (“NOLs”). The Initial Debtors estimated that they had federal NOLs of approximately \$61.1 million as of December 31, 2020. [Docket No. 7].
- Motion to Continue Operating Cash Management System. By this motion, the Initial Debtors sought to maintain a total of 11 existing bank accounts at Bell Bank, The Bank of New York Mellon, and Wells Fargo Bank and 11 non-debtor bank accounts at Wells Fargo as required under DLP IV’s and DLP VI’s secured credit agreements to maintain the Policy Portfolio. The Initial Debtors also sought to honor certain intercompany obligations. [Docket No. 8].
- Motion to Pay Taxes and Fees. By this motion, the Initial Debtors sought authorization to pay an estimated \$469,313 in prepetition taxes and fees that would become due and payable after the Initial Petition Date. [Docket No. 11].
- Motion to Maintain Insurance Programs. By this motion, the Initial Debtors sought the right to pay outstanding obligations that would allow the Initial Debtors to renew, maintain, and/or purchase various insurance policies. [Docket No. 6].
- Motion to Establish Certain Notice Procedures. By this motion, the Initial Debtors sought approval of the form and manner of notifying creditors of the commencement of the Initial Debtors’ Chapter 11 Cases. [Docket No. 9].
- Motion to Waive Equity List Requirement and File Consolidated Creditor Matrix. By this motion, the Initial Debtors sought (i) a waiver of the requirement to file a list of each Initial Debtor’s equity security holders and (ii) authorization to redact certain personally identifiable information for individual creditors. [Docket No. 16].
- Motion to Extend Schedules Filing Deadline. By this motion, the Initial Debtors sought an extension of the initial 14-day period to file their schedules of assets and liabilities and statements of financial affairs. [Docket No. 10].
- Motion to Appoint Donlin, Recano & Co. as Claims Agent. By this motion, the Initial Debtors sought entry of an order appointing DRC as claims, noticing, solicitation, and administrative agent. [Docket No. 12].

The Initial Debtors also filed several other motions subsequent to the Initial Petition Date to further facilitate the smooth and efficient administration of the Chapter 11 Cases and reduce the administrative burdens associated therewith, including:

- Retention Applications. On May 11, 2022, the Initial Debtors filed several applications seeking to retain certain professionals on a postpetition basis pursuant

to sections 327 and 328 of the Bankruptcy Code, including Mayer Brown, as restructuring counsel [Docket No. 222], FTI Consulting, as financial advisor [Docket No. 223], and PJT, as investment banker [Docket No. 224]. Between May 17, 2022 and May 20, 2022, the Initial Debtors filed applications seeking to retain Tran Singh LLP as special conflicts counsel [Docket No. 252], Jackson Walker as co-counsel and conflicts counsel [Docket No. 267], and Willkie Farr & Gallagher LLP (“Willkie Farr”) as special counsel [Docket No. 268]. The foregoing professionals are, in part, responsible for the administration of the Chapter 11 Cases. The postpetition compensation of all of the Initial Debtors’ professionals retained pursuant to sections 327 and 328 of the Bankruptcy Code is subject to the approval of the Bankruptcy Court.

- Interim Compensation Motion. On May 12, 2022, the Initial Debtors filed the *Debtors’ Motion for Order (I) Establishing Procedures for Interim Compensation and Reimbursement of Expenses for Professionals and (II) Granting Related Relief* [Docket No. 228] (the “Interim Compensation Motion”) to authorize the Initial Debtors to establish procedures for interim compensation and reimbursement of expenses for legal and other professionals retained to represent the Initial Debtors or any official committee appointed in the Chapter 11 Cases.
- Ordinary Course Professionals Motion. On May 24, 2022, the Initial Debtors filed the *Debtors’ Motion for (I) Entry of an Order Authorizing the Retention and Compensation of Certain Professionals Utilized in the Ordinary Course of Business and (II) Granting Related Relief* [Docket No. 291] (the “OCP Motion”) to authorize the Initial Debtors to retain and compensate certain law firms, accountants, tax professionals, and other non-attorney professionals utilized in the ordinary course of business.

On April 22, 2022, the Bankruptcy Court entered a case management order (the “Case Management Order”) directing the Initial Debtors to file a status report no later than May 16, 2022 to address the “concrete and particularized steps” that the Initial Debtors took to assure that there would be material inflows of cash from sources other than debtor-in-possession financing. [Docket No. 95]. Thereafter, the Initial Debtors took a number of steps to address the Bankruptcy Court’s concerns, including negotiating amendments to the DLP IV and DLP VI Facilities, holding meetings with the boards of the DLP Entities, and appointing additional independent directors. These actions are further described in Article VI.C.2 and Article VI.C.3. The Initial Debtors advised the Bankruptcy Court of these actions and addressed other issues identified in the Case Management Order pursuant to a status report filed on May 13, 2022. [Docket No. 248].

The First Day Motions, the First Day Declaration, all subsequently filed motions, all orders for relief granted in the Chapter 11 Cases, and all other pleadings can be viewed free of charge at <https://www.donlinrecano.com/Clients/gwg/Index>.

B. Appointment of Bondholder Committee, CRO and Independent Committees; LBM; Ad Hoc Broker/Dealer Committee

1. Appointment of Bondholder Committee

On May 9, 2022 [Docket No. 214], the U.S. Trustee appointed the Bondholder Committee, at that time constituted as a seven-member official committee of Bondholders in these Chapter 11 Cases. On June 17, 2022 [Docket No. 418], the U.S. Trustee reconstituted the Bondholder Committee to a six-member Bondholder Committee.

The Bondholder Committee selected Akin Gump Strauss Hauer & Feld LLP and Porter Hedges LLP as co-counsel, Piper Sandler & Co., through its restructuring group TRS Advisors, as investment banker, and AlixPartners as financial advisor.

2. Appointment of CRO and Independent Director Committees

On June 19, 2022, the board of directors of GWGH unanimously adopted resolutions (as subsequently amended and restated on July 13, 2022 and July 17, 2022, the “Resolutions”):

- a. designating Jeffrey S. Stein as Chief Restructuring Officer of GWGH, effective June 1, 2022;
- b. appointing Jeffrey S. Stein and Anthony R. Horton as independent directors of the GWGH board;
- c. forming the Investigations Committee of the board of directors of GWGH (the “Investigations Committee”) and appointing Jeffrey S. Stein and Anthony R. Horton as the sole members thereof;
- d. forming the Special Committee of the board of directors of GWGH (the “Special Committee,” and together with the Investigations Committee, the “Independent Committees”) and appointing Jeffrey S. Stein, Anthony R. Horton, and David F. Chavenson (each an “Independent Director” and, together, the “Independent Directors”) as the sole members thereof; and
- e. delegating specific authorities to the Investigations Committee and the Special Committee, respectively.

On June 20, 2022, the Initial Debtors filed the *Debtors’ Motion for Entry of an Order Authorizing (I) Designation of Jeffrey S. Stein as Chief Restructuring Officer, (II) the Appointment of Jeffrey S. Stein and Anthony R. Horton as New Independent Directors, and (III) Granting Related Relief* [Docket No. 430] (the “CRO and Directors Motion”). Following a hearing held on July 18, 2022, the Bankruptcy Court entered an order approving the CRO and Directors Motion, which authorized the Initial Debtors to, among other things, appoint the Independent Directors on the terms set forth in the Resolutions and retain Mr. Stein as Chief Restructuring Officer [Docket No. 594] (the “CRO and Directors Order”).

The Resolutions gave the Investigations Committee the exclusive authority to, among other things:

- a. initiate, design, establish, direct, administer, control and conduct an internal investigation (the “Independent Investigation”) of claims, causes of action and defenses to claims and causes of action that arise under or relate to any transaction, group of related transactions, relationships or conduct involving GWGH, any of its current and former subsidiaries and affiliates, and any third party, including, without limitation, Beneficient and current and former directors and officers, that occurred at any point prior to the filing of these Chapter 11 Cases (the “Investigation Matters”);
- b. examine, investigate, analyze, assess, and evaluate the terms and conditions of any Investigation Matters, and review, analyze, evaluate, monitor and exercise general oversight of all proceedings and activities of GWGH related to the Independent Investigation;
- c. prepare a report (the “Independent Report”) regarding the results of the Independent Investigation, to be provided to the Investigations Committee, including its conclusions regarding whether any claims or causes of action should be brought regarding the Investigation Matters; and
- d. on behalf of GWGH or any of its subsidiaries, and at the sole cost and expense of GWGH, with outside legal counsel engaged by the Investigations Committee, assert any claims or causes of action regarding any of the Investigation Matters described in the Independent Report, and/or to prosecute, settle, or assign any claims or causes of action regarding Investigation Matters; and take such other actions as the Investigations Committee may deem, in its sole judgment and discretion, to be necessary, advisable or appropriate for the Investigations Committee to discharge its duties.

The Resolutions gave the Special Committee the exclusive authority to, among other things:

- a. initiate, design, negotiate, seek Bankruptcy Court approval of and adopt any new compensation arrangements for officers of GWGH in connection with the Chapter 11 Cases;
- b. examine, investigate, analyze, assess, and evaluate the terms and conditions of the Shared Services Agreement, and the performance by GWGH and Beneficient thereunder, relating, in each instance, to the period following the commencement of these Chapter 11 Cases, and any actions that, in the Special Committee’s sole reasonable discretion, may or should be taken by GWGH with respect to the amendment or termination of the Shared Services Agreement and, with legal counsel engaged by the Special Committee, the assertion of any claim or cause of action thereunder, and to prosecute and settle any such claim or cause of action;
- c. examine, investigate, analyze, assess, evaluate and approve (or reject) the terms and conditions of any transaction or proposed transaction (or any component thereof) between GWGH or any of its subsidiaries, on the one hand, and any of GWGH’s or

any of its subsidiaries' equityholders, affiliates, subsidiaries, directors, managers, officers, or other stakeholders that presents an actual or potential conflict of interest, as reasonably determined by the Special Committee, between the Company and any such related party;

The Resolutions also gave the Special Committee the authority, in consultation with the Board, management, and the Debtors' advisors, as determined to be necessary or appropriate by the Special Committee in its sole reasonable discretion, to examine, investigate, analyze, assess, evaluate and negotiate the terms and conditions of (the following being referred to herein as the "Special Committee Chapter 11 Actions"):

- a. any debt financing proposal to be submitted to the Bankruptcy Court for approval in connection with these Chapter 11 Cases;
- b. any proposed sale of all or a portion of the Policy Portfolio or any of the Company's other assets;
- c. any proposed action to cause the chapter 11 filing of any of the GWGH's subsidiaries;
- d. any proposed plan of reorganization or liquidation to be submitted by the Debtors to the Bankruptcy Court for confirmation in connection with these Chapter 11 Cases; and
- e. any pleadings to be filed by the Company with the Bankruptcy Court requesting approval of the foregoing Special Committee Chapter 11 Actions.

Under the Resolutions, the board of directors of GWGH retained the authority to approve and authorize the Company's entry into any of the Special Committee Chapter 11 Actions, subject to the prior approval of the Special Committee.

The Independent Directors retained independent counsel, Katten Muchin Rosenman LLP ("Katten"), whose work in these Chapter 11 Cases has been at the sole direction of the Independent Directors. The Bankruptcy Court approved this retention on August 23, 2022. [Docket No. 687]. On September 16, 2022, the Investigations Committee retained an independent financial advisor, Province, LLC ("Province"), whose work in these Chapter 11 Cases has been at the sole direction of the Investigations Committee. The Bankruptcy approved this retention on November 8, 2022. [Docket No. 1047]. David F. Chavenson resigned from the Special Committee and the GWGH board on November 15, 2022.

3. Seller Trusts, Custody Trusts and LBM

As described above, as a result of certain prepetition transactions with Ben and the Company, the Seller Trusts acquired Seller Trust L Bonds and equity interests in GWGH. Additionally, on September 30, 2020, the Custody Trusts, at the sole direction of John A. Stahl, trust advisor of each such trust, entered into that certain *Contribution and Exchange Agreement* with certain Seller Trusts (the "Contribution and Exchange Agreement"). Under the Contribution and Exchange Agreement, the parties participated in an exchange of collateral that resulted in the Custody Trusts holding approximately 30% of GWGH's common stock and approximately 26% of the Seller Trust L Bonds.

(a) *The Seller Trusts*

The trustee of each of the Seller Trusts is Delaware Trust Company. The trust advisors of each trust were initially James E. Turvey and Murray T. Holland, but as of April 18, 2022, Mr. Turvey and Mr. Holland resigned, and the trust advisor is currently John A. Stahl, who has sole decision-making authority with respect to each Seller Trust.⁵² The sole beneficiary of each of the Seller Trusts is MHT Financial, L.L.C. Murray T. Holland, who is the former Chief Executive Officer of GWGH, has an indirect pecuniary interest in the assets of the Seller Trusts resulting from his ownership interest of 30% of the outstanding membership interests of MHT Financial, L.L.C. Until recently, Mr. Holland also served as the Chairman of the Board of GWGH. In addition to serving in these multiple roles, Mr. Holland acted as an advisor to Beneficient starting in 2014.

(b) *The Custody Trusts*

The Custody Trusts constitute six common law trusts for whom Delaware Trust Company is the trustee. The sole beneficiary of each Custody Trust is a separate certificate holder referred to as a liquid trust (the “Liquid Trusts”). John A. Stahl is the trust advisor of each of the six Liquid Trusts and has the sole decision-making authority with respect to each of the Custody Trusts. In connection with the Collateral Swap, on November 3, 2020, GWGH and the Liquid Trusts entered into a *Stockholders Agreement* (the “Stockholders Agreement”), and concurrently, each of the Custody Trusts entered into a joinder to the Stockholders Agreement with respect to the shares held by the Custody Trusts. The Stockholders Agreement limited the voting power of the Liquid Trusts and Custody Trusts. Specifically, until the Seller Trusts beneficially own less than 20% of the total voting power of GWGH’s common stock, the Liquid Trusts and Custody Trusts will vote solely in proportion with the votes cast by all stockholders.

(c) *LBM*

As discussed in Article II.B.2 of this Disclosure Statement, the Debtors understand that, pursuant to certain powers of attorney, the Custody Trusts and Seller Trusts designated LBM as agent with respect to claims (and related litigation) relating to the Seller Trust L Bonds; however, LBM has not authority or control over any equity interests held by the Seller Trusts or Custody Trusts. LBM is a special purpose entity formed under Delaware law that is charged with maximizing recoveries on the Seller Trust L Bonds. The powers of attorney also grant LBM authority to act for the Custody Trusts and Seller Trusts in any bankruptcy proceedings affecting the property of such trust. John A. Stahl is the sole manager of LBM. Richard Schmidt was appointed by John A. Stahl, in his capacity as the manager of LBM, as the restructuring manager for LBM with the power and authority to act on behalf of LBM including, but not limited to, the Chapter 11 Cases. LBM is represented by Okin Adams Bartlett Curry LLP, as legal counsel, and Gordian Group, as investment banker.

⁵² On March 26, 2023, Dr. Stahl submitted his written resignation as trust advisor of the Seller Trusts only; such written resignation is effective 30 days after received (i.e., April 25, 2023) in accordance with the terms of applicable Seller Trust agreements. Dr. Stahl has not indicated that he intends to resign as trust advisor for the Custody Trusts or as the sole manager of LBM. LBM advises that, notwithstanding Dr. Stahl’s resignation as trust advisor for the Seller Trusts, as of the date hereof, LBM still holds valid Durable Powers of Attorney with respect to both the Custody Trusts and the Seller Trusts.

4. Ad Hoc Committee of Brokers/Dealers

As noted herein, the Company sold bonds through a network of 145 registered broker/dealers and registered investment advisers (i.e., the Broker Dealers). A group of these Broker Dealers, having the interests disclosed in the *Verified Statement of Proskauer Rose LLP Pursuant to Federal Rule of Bankruptcy Procedure 2019* [Docket No. 900], as it may be supplemented from time to time, has formed an ad hoc committee (the “Ad Hoc Broker/Dealer Committee”). The Ad Hoc Broker/Dealer Committee is represented by Proskauer Rose LLP.

C. Financing Matters; Filing of DLP IV and DLP VI

1. The Interim DIP Facility

Prior to the Initial Petition Date, PJT initiated a process to raise liquidity on an exigent basis and solicited proposals for bridge financing and debtor-in-possession financing. Despite such efforts, the Company was unsuccessful in its attempts to obtain medium or long-term prepetition bridge financing that it deemed satisfactory. Through PJT’s efforts, and despite the time constraints imposed by the Company’s extraordinarily difficult liquidity constraints, the Company received four proposals to provide debtor-in-possession financing and ultimately accepted the proposal of National Founders and certain related parties (the “Interim DIP Lenders”) for a multi-draw term loan facility (the “Interim DIP Facility”).

Accordingly, on the Initial Petition Date, among other first-day relief sought, the Initial Debtors filed the *Debtors’ Emergency Motion for Interim and Final Orders (I) Authorizing the Debtors to Obtain Postpetition Financing, (II) Authorizing the Debtors to Use Cash Collateral, (III) Granting Liens and Superpriority Claims, (IV) Modifying the Automatic Stay, (V) Authorizing the DLP VII Option Upon Entry of the Final Order, (VI) Scheduling a Final Hearing, and (VII) Granting Related Relief* [Docket No. 13] (the “Interim DIP Motion”) seeking authorization to enter into the Interim DIP Facility with the Interim DIP Lenders in an aggregate principal amount equal to \$65 million, \$18 million of which would be available on an interim basis. The Interim DIP Motion also previewed that the Initial Debtors reserved the right to seek Bankruptcy Court approval of an option held by the Interim DIP Lenders (the “DLP VII Option”) pursuant to which the Interim DIP Lenders could elect to refinance in full the DLP IV Facility and the DLP VI Facility by (a) entering into a new credit facility at a newly formed non-debtor subsidiary special purpose vehicle, DLP VII; (b) and transferring the entire policy portfolio, pursuant to section 363 of the Bankruptcy Code, to DLP VII. At the time of the negotiation of the Interim DIP Facility, the Initial Debtors expected the DLP VII Option to result in the payment in full of the amounts then owing under the Interim DIP Facility, while allowing the Initial Debtors to retain the Interim DIP Facility proceeds to fund the Chapter 11 Cases.

Following a hearing on the Interim DIP Motion held on April 21, 2022, the Bankruptcy Court entered an order approving the Interim DIP Motion on an interim and modified basis [Docket No. 124] (the “Interim DIP Order”), which order authorized the Initial Debtors to borrow \$10 million under the Interim DIP Facility. Thereafter, three stipulations and agreed orders were entered [Docket Nos. 205, 349 and 381], which, among other things, reset the final hearing on the Interim DIP Motion and set and extended other deadlines in connection with the Interim DIP Facility.

2. The DLP IV Facility

As set forth in Article V.B.1 herein, prior to the Initial Petition Date, the Company and the DLP IV Lender Parties entered into certain amendments for the DLP IV Facility to, among other things, waive certain defaults, advance additional funds to DLP IV to pay premiums, pay various fees and expenses and adjust the interest rate.

The DLP IV Lender Parties sought clarification from the Bankruptcy Court that DLP IV could borrow under the DLP IV Facility to make premium payments to maintain DLP IV's Policy Portfolio without violating the Case Management Order. By order dated April 28, 2022 [Docket No. 171], the Bankruptcy Court confirmed such clarification.

Thereafter on June 27, 2022, DLP IV and the DLP IV Lender Parties negotiated a second loan agreement amendment (the "Second DLP IV Amendment"), that, among other things, (a) provided that LNV would make advances to cover any shortfall to the extent DLP IV did not have sufficient cash (after reserving in a specified account for two months' worth of premiums) to make payments for premiums, and (b) DLP IV would pay monthly management fees to Debtor GWG Life in the amount of \$3,500 per year per Policy for the Policies owned by DLP IV. The Second DLP IV Amendment also reflected revisions to address the Bondholder Committee's concerns. The Second DLP IV Amendment also granted DLP IV the option to purchase the DLP IV Lender Parties' Residual Beneficial Interest at a price equal to or greater than \$20,000,000.

Thereafter the DLP IV Lender Parties sought further clarification from the Bankruptcy Court that the terms of the Second DLP IV Amendment did not violate the Case Management Order. By order entered on June 21, 2022 [Docket No. 444], the Bankruptcy Court confirmed that the DLP IV Lender Parties' entry into the Second DLP IV Amendment did not violate the Case Management Order.

On October 12, 2022, the DLP IV Lender Parties entered into a further loan agreement amendment, that, among other things, (a) provided that LNV would continue to make advances for scheduled premium payments through February 1, 2023, to cover any shortfall to the extent DLP IV did not have sufficient cash to make payments for such premiums, and (b) permitted the reasonable and documented fees and expenses of counsel to the independent directors of DLP IV, and certain other expenses set forth in the approved budget, to be paid by DLP IV.

3. The DLP VI Facility

As set forth above, prior to the Initial Petition Date, DLP VI and the National Founders entered into certain waivers and amendments to the DLP VI Facility, to, among other things, waive certain defaults, advance additional funds to DLP VI to pay premiums, pay various fees and expenses and revised the terms of a yield maintenance premium.

On June 28, 2022, DLP VI entered into an amendment of the DLP VI Facility (the "Second DLP VI Amendment") that, among other things, (a) provided for the payment of monthly management fees to Debtor GWG Life in the amount of \$3,500 per year per Policy for Policies owned by DLP VI through November 1, 2022, and (b) waived any potential default or event of default that may occur as a result of a deficiency in the amount of funds required to be held in the

premium reserve account prior to September 16, 2022. The Second DLP VI Amendment also reflected revisions to address the Bondholder Committee's concerns.

National Founders also requested clarification from the Bankruptcy Court that the terms of the Second DLP VI Amendment did not violate the Case Management Order. By order entered on June 21, 2022 [Docket No. 445], the Bankruptcy Court confirmed the Initial Debtors' entry into the Second DLP VI Amendment did not violate the Case Management Order.

On September 14, 2022, the DLP VI Lender Parties entered into a letter agreement which provided for additional protective advances and extended the waiver period set forth in the Second DLP VI Amendment to December 31, 2022. On October 14, 2022, the DLP VI Lender Parties entered into a further loan agreement amendment, pursuant to which National Founders made an advance in October 2022 to DLP VI that permitted DLP VI to make scheduled premium payments.

4. The Chapford DIP Facility

Following entry of the Interim DIP Order and the Bankruptcy Court's guidance to invite willing participants to offer alternative financing proposals, PJT and the Initial Debtors immediately commenced an additional postpetition marketing process to determine if there were any offers on terms that were higher or better than the Interim DIP Facility. To that end, PJT, the Initial Debtors and their advisors conducted a robust, comprehensive, and competitive marketing process over the course of more than two months to provide the Initial Debtors with as many potential financing and sale options on the best available terms as possible. In addition, the Initial Debtors simultaneously created a process by which to oversee and evaluate any bids in connection with this marketing process through the appointment of the CRO and the Independent Directors and the formation of the Independent Committees, as discussed above.

The Initial Debtors and their advisors reached out to over 50 parties, including additional parties recommended by the Bondholder Committee's professionals, to ascertain and solicit interest regarding a potential alternative transaction, whether in the form of a refinancing, an outright sale of the Policy Portfolio, or other monetization alternative. The Initial Debtors ultimately received three potentially-viable financing proposals and concluded the replacement DIP financing offer (the "Chapford DIP Facility") from entities related to Blue Owl Capital Inc., including Chapford SMA Partnership LP and related parties (collectively, "Chapford"), was indisputably the strongest offer, as it, among other things (a) improved upon the Interim DIP Facility by providing \$65 million in additional liquidity and eliminated the DLP VII Option; (b) extended the maturity date from October 20, 2022 to December 31, 2022; (c) offered a one-way sale put option (the "Chapford Put Option") at no cost as protection against downside risk in connection with any sale of the Policy Portfolio at a later date, and obligated Chapford to act as a stalking horse bidder for the Policy Portfolio with a \$610 million purchase price (subject to adjustments) in the event the Debtors decided to sell the Policy Portfolio; and (d) provided lower interest rates and fees than the Interim DIP Facility. The Chapford DIP Facility also included certain case milestones that remain in effect, including an October 31, 2022 milestone (as extended by stipulation and agreed order from the initial October 15, 2022 date) that required the Debtors to (a) file a chapter 11 plan that would repay the Chapford DIP Facility in full in cash on such plan's effective date or documentation evidencing a financing or other transaction that provided for payment in full in cash of the obligations under the Chapford DIP Facility; or (b) if the Debtors

pursued a sale process, and in connection with the DLP Entities' voluntary commencement of chapter 11 cases, exercise the Chapford Put Option and file a motion to approve bid procedures.

In sum, the Debtors concluded that entering into the Chapford DIP Facility was a sound exercise of their business judgment at that time, on the basis that the flexibility and liquidity provided by the Chapford DIP Facility was critical, the Debtors were not obligated to pursue a sale under the Chapford DIP Facility, and the Debtors were not constrained from pursuing higher or better offers.

On July 4, 2022, the Initial Debtors filed the *Supplement to the Debtors' Emergency Motion for Interim and Final Orders (I) Authorizing the Debtors to Obtain Postpetition Financing, (II) Authorizing the Debtors to Use Cash Collateral, (III) Granting Liens and Providing Claims with Superpriority Administrative Expense Status, (IV) Modifying the Automatic Stay, and (V) Granting Related Relief* [Docket No. 491], seeking Bankruptcy Court approval of the Chapford DIP Facility. Following the final hearing held on the Chapford DIP Facility on July 18, 2022, the Bankruptcy Court entered the *Final DIP Order (I) Authorizing the Debtors to Obtain Postpetition Financing, (II) Authorizing the Debtors to Use Cash Collateral, (III) Granting Liens and Providing Claims with Superpriority Administrative Expense Status, (IV) Modifying the Automatic Stay, and (V) Granting Related Relief* [Docket No. 606] (the "Chapford DIP Order") approving the Chapford DIP Facility. The Chapford DIP Order reflected numerous concessions and agreements by and among Chapford, the Debtors, the Bondholder Committee and other parties-in-interest.

5. The Vida Replacement Financing Option

In furtherance of their development of a value maximizing chapter 11 plan, the Debtors procured from VICOF III Acquisition, LLC, an affiliate of Vida Capital, Inc. (collectively, "Vida"), an exercisable option (the "Vida Replacement Financing Option") under which the Debtors had the option to elect to enter into a \$630 million replacement debtor-in-possession financing facility (the "Vida Replacement Financing Facility") as well as exit financing. The Vida Replacement Financing Option permitted the Debtors to refinance the Chapford DIP Facility within the required timeframe using proceeds of the Vida Replacement Financing Facility, provided additional liquidity and an extension of the maturity date, and also secure access to exit financing, under certain conditions, for a plan of reorganization in an aggregate amount of up to \$630 million. Specifically, the Vida Replacement Financing Facility comprised the following components: (a) (i) a \$590 million replacement debtor-in-possession facility, which would replace the Chapford DIP Facility and repay in full the valid claims of the DLP Debtors' secured lenders, and (ii) a \$40 million senior secured credit facility upon effectiveness of the Second Amended Plan (collectively, the "Vida DIP Facility"); and (b) exit financing for the Debtors (the "Vida Exit Financing Facility"). The Vida Exit Financing Facility would allow the Debtors to retain and ultimately maximize the residual value of the Policy Portfolio. On October 11, 2022, the Bankruptcy Court approved the Initial Debtors' entry into, but not exercise of, the Vida Replacement Financing Option. [Docket No. 865].

6. Election of Vida Replacement Financing Option

At the October 11, 2022 hearing on the Initial Debtors' motion to approve entry into the Vida Replacement Financing Option, the Bankruptcy Court required that, in advance of exercising

either the Vida Replacement Financing Option or the Chapford Put Option, the Initial Debtors file a statement of intent to exercise their chosen option, and, following the filing of such statement, the Bankruptcy Court would evaluate whether the Initial Debtors' determination of which option to exercise was supported by the Initial Debtors' business judgment.

The Initial Debtors ultimately determined that the Vida Replacement Financing Option was superior to any available alternative, including the Chapford Put Option and, accordingly, on October 25, 2022, the Initial Debtors filed their *Statement of Intent to Elect Vida Option and Memorandum in Support Thereof* [Docket No. 920] (the "Vida Election Statement"). As set forth in the Vida Election Statement, the Initial Debtors' determination was based on analysis and information provided by their in-house expert on the Policy Portfolio, a third-party life settlements expert, and the Initial Debtors' advisors, indicating that (1) exercising the Vida Replacement Financing Option is expected to provide more cash up front than the Chapford Put Option, and is highly likely to provide additional value over time, (2) no better financing or purchase offer is likely forthcoming, (3) the Debtors or other successor holders of the Policy Portfolio are unlikely to default on the exit facility contemplated under the Vida Replacement Financing Option if such option were exercised, and (4) the Vida affiliate intended to serve as lender is an investment grade counterparty that is expected to fully honor its obligations with respect to the Vida Replacement Financing Option.⁵³

At the October 27, 2022 hearing to consider the Initial Debtors' intent to exercise the Vida Replacement Financing Option, the Bankruptcy Court confirmed that the Initial Debtors' determination to exercise the Vida Replacement Financing Option was supported by their business judgment and that, accordingly, the Initial Debtors could proceed to exercise the Vida Replacement Financing Option in accordance with its terms. Accordingly, on October 31, 2022, the Debtors exercised the Vida Replacement Financing Option and, in conjunction therewith, filed the voluntary chapter 11 petitions of the DLP Entities, and the motion seeking approval of the Vida Replacement Financing Option, which sought: (1) immediate approval of the Vida DIP Facility; and (2) at a later time, approval of the Vida Exit Financing Facility. [Docket No. 975].

Following the final hearing held on the Vida DIP Facility on December 1, 2022, the Bankruptcy Court entered the *Final Order (A) Authorizing the Debtors to Obtain Replacement DIP Financing from Vida Insurance Credit Opportunity Fund II GP, LLC and its Affiliates and Enter Into and Perform Under the Replacement DIP Credit Documents, (B) Authorizing the Debtors to Use Cash Collateral, (C) Granting Liens, and Providing Claims with Superpriority Administrative Expense Status, (D) Authorizing the Refinancing of Prepetition and Postpetition Secured Debt, (E) Authorizing Amending the Option Agreement, (F) Modifying the Automatic Stay, and (G) Granting Related Relief* [Docket No. 1144] (the "Vida DIP Order") approving the Vida DIP Facility. The Vida DIP Facility was entered into on December 15, 2022, and concurrently therewith the Chapford DIP Facility, DLP IV Facility and DLP VI Facility were each paid in full.

⁵³ Fifth Season Investments LLC ("Fifth Season"), the successor in interest to Chapford, filed a statement in response to the Vida Election Statement [Docket No. 937] that asserted that Fifth Season is entitled to an alternative stalking horse fee in the amount of \$18.3 million on the basis that the Vida Exit Financing Facility is a disguised sale rather than a bona fide financing transaction. The Debtors dispute the allegations asserted by Fifth Season in its statement, and such dispute remains unresolved as of the date of this Disclosure Statement.

7. Developments Leading to the DLP Petition Date

Subsequent to the filing of the Initial Debtors' Chapter 11 petitions, the Bankruptcy Court and various creditor constituents expressed concerns about (a) the use of the Initial Debtors' funds to support the assets of the non-debtor DLP Entities; and (b) the organizational structures of the DLP Entities could allow such entities to inhibit a value maximizing restructuring process for the Initial Debtors by preventing such entities from seeking relief under chapter 11 of the Bankruptcy Code. In response to these concerns, on May 13, 2022, counsel for the Debtors made a presentation to the respective boards of directors of the DLP Entities, which included an emphasis on the fiduciary duties of the directors, particularly in the context of any proposal that would result in payment in full of all of the respective creditors of the DLP Entities and a substantial return to the Initial Debtors on account of their direct and indirect equity interests in the DLP Entities. At the request of the Bankruptcy Court, the Initial Debtors filed a status report with respect to the foregoing, which included a summary of the presentation. [Docket No. 248].

Starting on September 7, 2022, counsel for the Debtors have made weekly presentations to the boards of directors of the DLP Entities. In September 2022, one of the two independent directors for the DLP IV board of directors, Sean Clements, retained independent counsel, Paul Hastings LLP, whose work in connection with these Chapter 11 Cases has been at the sole direction of Mr. Clements in his capacity as independent director at DLP IV. Similarly, in September 2022, Albert Fioravanti, the other independent director for the DLP IV board of directors – who is also the independent director for the DLP VI board of directors – retained independent counsel, Mintz & Gold LLP, whose work in connection with these Chapter 11 Cases has been at the sole direction of Mr. Fioravanti in his capacity as independent director at DLP IV and DLP VI. On October 25, 2022, the boards of directors at DLP Entities each formed a conflicts committee, with the independent directors at each entity being appointed to serve on the respective committees (collectively, the “DLP Conflicts Committees”). The DLP Conflicts Committees were tasked and granted the sole board authority to investigate, among other things, transactions and other matters involving the relevant DLP Entity, on the one hand, and creditors or affiliates of the relevant DLP Entity, on the other. Paul Hastings LLP is counsel to the DLP IV Conflicts Committee, and Mintz & Gold LLP is counsel to the DLP VI Conflicts Committee.

As discussed above, after an extensive marketing process, the Initial Debtors had obtained two viable facilities to fund their exit from chapter 11: the Chapford DIP Facility and the Vida Exit Financing Facility. Importantly, however, both the Chapford Put Option and the Vida Replacement Financing Option required, as a condition precedent to exercising each option, the DLP Entities to commence Chapter 11 cases on or before October 15, 2022 (which was extended in both instances to October 31, 2022).

On October 28, 2022, counsel for the Debtors made another presentation to the boards of directors for the DLP Entities, which described the necessity of the DLP Entities to commence Chapter 11 cases to allow the milestones under the Chapford DIP Order and Vida Replacement Financing Option to be met, which were the only sources of repayment for the credit facilities at each entity. After careful deliberation, the DLP Entities' respective boards of directors each determined that authorizing the DLP Entities to commence Chapter 11 cases was in the DLP Entities' best interests because, in addition to maximizing value for the Debtors and their stakeholders, it would also maximize the value of the Policy Portfolio, satisfying the existing

lenders of the respective DLP Entities in full, and provide a substantial return to their respective equity holders. As noted previously, the credit facilities of the respective DLP Entities were paid in full with the closing of the Vida DIP Facility.

8. DLP Entities' Petition Date

The DLP Entities each filed petitions for bankruptcy under chapter 11 of the Bankruptcy Code on October 31, 2022. In connection with their petitions, the DLP Entities also filed motions for joint administration with the Initial Debtors' Chapter 11 Cases, authorization to continue to operate their respective cash management system and maintain their respective existing bank accounts, authorization to use cash collateral of their respective lenders, and an extension of time to file their respective Schedules of Assets and Liabilities and Statement of Financial Affairs. A further description of the matters leading up to the commencement of the DLP Entities' Chapter 11 Cases and their first day motions is set forth in the *Declaration of Timothy Evans, Chief Financial Officer of GWG Holdings, Inc. and Board Member of the DLP Debtors, in Support of the DLP Debtors' Chapter 11 Petitions and First Day Motions* [Docket No. 976].

More specifically, the DLP Entities filed the *DLP Entities' Emergency Motion for Interim Orders (I) Authorizing the Use of DLP Cash Collateral, (II) Granting Adequate Protection to the Prepetition DLP Secured Parties, (III) Modifying the Automatic Stay, and (IV) Scheduling a Final Hearing* [Docket No. 985] (the "DLP Cash Collateral Motion") seeking authorization of the DLP Entities to use the respective DLP Cash Collateral (as defined therein) with the consent of the respective DLP Entities' Senior Secured Parties.

The Bankruptcy Court held a hearing on the DLP Entities' Cash Collateral Motion, among other "first day" motions for the DLP Entities, on November 2, 2022. Following discussions with the DLP Senior Secured Parties and the Bondholder Committee to resolve certain objections of the Bondholder Committee to the DLP Cash Collateral Motion, including adding clarifying language requested by the Court regarding the fiduciary duties of the directors and officers of each of the DLP Entities to the respective DLP Entities' bankruptcy estates, the Bankruptcy Court entered (1) an interim order approving the DLP Cash Collateral Motion with respect to DLP IV's use of cash collateral on November 2, 2022 [Docket No. 1014] (the "DLP IV Cash Collateral Order"), and (2) an interim order approving the DLP Cash Collateral Motion with respect to DLP VI's use of cash collateral on November 4, 2022 [Docket No. 1032] (the "DLP VI Cash Collateral Order").⁵⁴

Additionally, the Bankruptcy Court entered orders (1) extending the time the DLP Entities have to file their Schedules of Assets and Liabilities and Statement of Financial Affairs to December 14, 2022 [Docket No. 1008], and (2) directing the joint administration of the DLP Entities' chapter 11 cases with the chapter 11 cases of the Initial Debtors for procedural purposes only [Docket No. 970] (the "DLP Joint Administration Order").

⁵⁴ Hearings on the interim cash collateral orders were initially set for December 9, 2022. However, because the Vida DIP Facility paid the DLP IV Facility and DLP VI Facility in full, there were no further orders entered with respect to the Debtors' use of cash collateral under these credit facilities.

9. Settlements With the DLP Secured Parties

As a condition to final approval and closing of the Vida DIP Facility (which was required to occur no later than December 15, 2022 under the Vida DIP Facility documentation), the Debtors understood that Vida required the irrevocable release of all liens in favor of the DLP Senior Secured Parties (or that certain arrangements be made to consummate such releases immediately following closing), and DLP IV's purchase of the Residual Beneficial Interest from the DLP IV Agent. However, the December 15, 2022 deadline to close the Vida DIP Facility would occur prior to the Challenge Period Termination Date (under the DLP IV Cash Collateral Order) and the Investigation Termination Date (under the DLP VI Cash Collateral Order). Furthermore, the DLP Senior Secured Parties indicated that they would be unwilling to grant the required lien releases in connection with the Vida DIP Facility unless all obligations under their respective credit facilities are indefeasibly paid in full, the stipulations, releases and indemnities in the DLP IV Cash Collateral Order and the DLP VI Cash Collateral Order were made final, binding and irrevocable, and, as to DLP IV, the Residual Beneficial Interest was repurchased on acceptable terms.

Following extensive negotiations with the Debtors, the Bondholder Committee, the Investigations Committee, the DLP Conflicts Committees, and the DLP Senior Secured Parties, the parties agreed to compromises set forth in the *Debtors' Emergency Motion for Entry of Orders (I) Approving Settlements Among the Debtors, the DLP Secured Parties, and Other Parties in Interest, and (II) Granting Related Relief* [Docket No. 1121] (the "DLP Settlement Motion") and related orders (the "DLP Settlement"). Pursuant to the DLP Settlement, in addition to the other terms incorporated therein, (1) the DLP IV Lender Parties agreed to a \$2.15 million reduction to the purchase price for the Residual Beneficial Interest, from \$20 million to \$17.85 million, and (2) the DLP VI Lender Parties agreed to a 10% discount of the amount of the Acceleration Prepayment Premium Amount (as defined in the DLP VI Facility), an approximately \$1.5 million reduction. Together, the DLP Settlements provide more than \$3.6 million in direct cash benefit to the Debtors, in addition to minimizing professional fees that could potentially be incurred litigating issues relating to the credit facilities. On December 1, 2022, the Bankruptcy Court approved the DLP Settlement, entering orders with respect to each settlement. The DLP Settlement facilitated the timely closing of the Vida DIP Facility on December 15, 2022 which paid the DLP Senior Secured Parties in full.

D. Exclusivity

Under the Bankruptcy Code, a debtor has the exclusive right to file and solicit acceptances of a plan or plans of reorganization for an initial period of 120 days from the date on which the debtor filed for voluntary relief (which may be extended by the Bankruptcy Court of a period of up to 18 months from the petition date). Prior to the expiration of the Initial Debtors' initial 120-day exclusive filing period, the Initial Debtors filed a motion, and the Bankruptcy Court entered an order, extending the Initial Debtors' exclusive periods to file and solicit a chapter 11 plan. [Docket 675 and 756]. Since then, the Initial Debtors have filed additional motions to extend such exclusive filing and solicitation periods. [Dockets No. 835, 857, 953, 958, 1035 and 1039]. The most recent order extending the exclusivity deadlines was entered on December 1, 2022, and pursuant to that order, the Initial Debtors' exclusive period to file and solicit a chapter 11 plan was extended to December 1, 2022 and February 14, 2023, respectively. [Docket No. 1146]. The Initial Debtors filed the Initial Plan on December 1, 2022,

thereby meeting the milestone required to maintain exclusivity with respect to filing a plan of reorganization. The DLP Entities' initial exclusivity periods, pursuant to 11 U.S.C. § 1121(b), commenced as of the DLP Petition Date. On February 13, 2023, the Debtors filed a motion seeking an extension of the time period to solicit votes on a plan of reorganization by an additional 90 days, to May 15, 2023. [Docket No. 1428].

Pursuant to the Mediated Settlement, the Creditor Proponents have agreed to not oppose the extension of the Debtors' exclusive period to solicit a chapter 11 plan through the earlier of (a) the date set for the Confirmation Hearing, and (b) June 23, 2023, with the understanding that the Creditor Proponents may oppose a requested extension by the Debtors beyond the foregoing.

E. Schedules and Statements

On June 18, 2022, the Initial Debtors filed their Schedules of Assets and Liabilities and Statement of Financial Affairs. [Docket Nos. 422-427]. On January 30, 2023, GWGH and GWG Life filed amended States of Financial Affairs. [Dockets Nos. 1397, 1398]. On December 14, 2022, the DLP Entities filed their Schedules of Assets and Liabilities and Statement of Financial Affairs. [Docket Nos. 1231-1236].

F. Establishment of Claims Bar Dates and Related Claims Procedures

On April 22, 2022, upon the Court's own motion during the hearing held on April 21, 2022, the Initial Debtors filed a proposed order setting bar dates for filing proofs of claim. [Docket No. 105]. On April 23, 2022, the Bankruptcy Court approved the order, establishing July 29, 2022 as the general claims bar date and October 17, 2022 as the governmental claims bar date (the "Bar Date Order"). [Docket No. 126].

The Initial Debtors have worked closely with the Bondholder Committee and Indenture Trustee to establish procedures for the full and final resolution of Bondholder claims. To reduce uncertainty and administrative burdens, the Initial Debtors filed their (a) *Emergency Motion for Entry of an Order (I) Modifying Bar Date Order, (II) Exempting Bondholders and Indenture Trustee from Filing Proofs of Claim Prior to Claims Bar Date, and (III) Granting Related Relief* [Docket No. 419], seeking approval of, among other things, exempting Bondholders from filing proofs of claim, which motion was approved by order entered on June 24, 2022 [Docket No. 464]; and (b) *Emergency Motion for Entry of an Order (I) Modifying Bar Date Order, (II) Establishing Procedures for Allowance of Bondholder and Indenture Trustee Claims, and (III) Granting Related Relief* [Docket No. 685], seeking approval of, among other things, notices to Bondholders of their claims and information on the process to dispute such claims, which motion was approved by order entered on August 29, 2022 [Docket No. 739] (the "Bondholder Claim Procedures Order").

Pursuant to the Bondholder Claim Procedures Order, Bondholders are exempt from the requirement to file Proofs of Claim with respect to claims for principal and interest under the Bonds, and other claims held by Bondholders were required to be filed no later than November 4, 2022 (the "Bondholder Bar Date"). The Bondholder Claim Procedures Order also provides for the automatic allowance of principal and interest claims held by Bondholders, (a) with respect to

registered holders of Bonds, as of the Bondholder Bar Date, and (b) with respect to beneficial holders of Bonds held through DTC, upon entry of the Bondholder Claim Procedures Order. Additionally, the Bondholder Claim Procedures Order gave the opportunity for registered holders of Bonds to dispute the applicable principal and interest amounts reflected in the Debtors' books and records, as set forth in individualized notices provided to each such registered holder of Bonds.

G. Executory Contracts and Unexpired Leases

1. Certain Leases

On April 20, 2022, the Initial Debtors filed their *Motion for Entry of an Order (I) Authorizing the Rejection of Certain Unexpired Leases Effective As of the Petition Date, and (II) Granting Related Relief* (the "Lease Rejection Motion") [Docket No. 45], seeking to reject an unexpired lease for office space in Minneapolis, Minnesota (the "Minnesota Lease") that the Debtors no longer needed. U.S. Bank National Association, the lessor under the Minnesota Lease, objected to the *nunc pro tunc* relief requested in the Lease Rejection Motion. The Debtors and U.S. Bank ultimately entered into a stipulation agreeing to the rejection of the Minnesota Lease and the allowance of an administrative expense claim for U.S. Bank, which the Court approved following a hearing on the matter on September 20, 2022. [Docket No. 772].

2. Shared Services Agreement

As noted above, the Special Committee of the GWGH board has been given authority to examine and investigate the Shared Services Agreement. More specifically, the Special Committee has the exclusive authority to examine, investigate, analyze, assess, and evaluate the terms and conditions of the Shared Services Agreement, and the performance by the Company and Beneficient thereunder, relating, in each instance, to the period following the commencement of the Chapter 11 Cases, and any actions that, in the Special Committee's sole discretion, may or should be taken by the Company with respect to the amendment or termination of the Shared Services Agreement and the assertion of any Claim or Cause of Action thereunder, and to prosecute and settle any such Claim or Cause of Action.

Pursuant to Article IV.V of the Second Amended Plan, on and after the Effective Date, it is expected, whether as the result of the rejection of the Shared Services Agreement or a consensual resolution and termination thereof, that there will be no continuing or other business relationship between the Wind Down Debtors, Wind Down Trust, or Litigation Trust, on the one hand, and Beneficient, on the other, of any nature or type whatsoever, other than the Wind Down Trust's ownership of interests in Beneficient constituting the Wind Down Assets, except as may be necessary or advisable to effectuate a smooth transition of shared services from Beneficient to Portfolio Co. or the Wind Down Trust. The terms of any continued relationship with Beneficient, including any amounts proposed to be paid to Beneficient, necessary to effect such transition shall be subject to the Proponents' Consent Right.

3. Rejection and Assumption of Executory Contracts and Unexpired Leases

Prior to the applicable Petition Date and in the ordinary course of business, the Debtors entered into certain Executory Contracts and Unexpired Leases. The Debtors, with the assistance

of their advisors, are reviewing the Executory Contracts and Unexpired Leases to determine which contracts and leases they will assume, assume and assign, or reject pursuant to sections 365 or 1123 of the Bankruptcy Code. The Debtors intend to include information in the Plan Supplement regarding the assumption or rejection of the Executory Contracts and Unexpired Leases, but may also elect to assume or reject various of the Debtors' Executory Contracts and Unexpired Leases before such time.

On the Effective Date, except as otherwise provided in the Second Amended Plan, including with respect to the Debtor's D&O Liability Insurance Policies, as described below, all Executory Contracts or Unexpired Leases will be deemed rejected in accordance with the provisions and requirements of sections 365 and 1123 of the Bankruptcy Code, other than: (1) those that are identified on the Schedule of Assumed Executory Contracts and Unexpired Leases; (2) those that have been previously assumed, assumed and assigned, or rejected by a Final Order; (3) those that are the subject of a motion to assume, assume and assign, or reject Executory Contracts or Unexpired Leases that is pending on the Confirmation Date; (4) those that are subject to a motion to assume, assume and assign, or reject an Executory Contract or Unexpired Lease pursuant to which the requested effective date of such assumption, assumption and assignment, or rejection is after the Effective Date; or (5) those Executory Contracts and Unexpired Leases that expired pursuant to the terms thereof before the applicable Petition Date.

Entry of the Confirmation Order shall constitute a Final Order approving the assumptions, assumptions and assignments, or rejections of such Executory Contracts or Unexpired Leases as provided under the Second Amended Plan or the Schedule of Assumed Executory Contracts and Unexpired Leases, pursuant to sections 365(a) and 1123 of the Bankruptcy Code. Unless otherwise indicated, assumptions or rejections of Executory Contracts and Unexpired Leases pursuant to the Second Amended Plan are effective as of the Effective Date. Any motions to assume Executory Contracts or Unexpired Leases pending on the Effective Date shall be subject to approval by a Final Order of the Bankruptcy Court on or after the Effective Date.

Although their analysis is ongoing, and aside from any resolution of the Shared Services Agreement, the Debtors currently estimate that the aggregate amount of Claims arising from the rejection of Executory Contracts and Unexpired Leases will not be significant.

4. D&O Liability Insurance Policies

(a) The Debtors' D&O Liability Insurance Coverage

As of the Initial Petition Date, the Debtors were covered under two separate towers of D&O Liability Insurance Policies. A tower of insurance policies refers to a series of insurance policies in which there is a primary policy that is the first policy that the insured looks to, followed by one or more excess policies that provide the same or similar coverage in case the amount of insurance under the primary policy is fully exhausted. Standard D&O (directors standing for "D" and officers standing for "O" in the common abbreviation, "D&O") insurance policies provide one or more of the following three types of coverage:

- Side A “Liability Coverage, which protects only the corporation’s directors and officers and only applies when the corporation is unable to indemnify them against a claim;
- Side B “Indemnification” Coverage, which provides insurance only for the corporation and only when it agrees to indemnify its directors and officers against a claim; and
- Side C “Entity” Coverage, which insures only the corporation and typically only when the corporation is a defendant in a “securities action.”

Of the Debtors’ two separate towers of D&O Liability Insurance Policies, one such tower of policies (the “Shared D&O Policies”), was obtained approximately two years prior to the Initial Petition Date. In addition to the Debtors and their directors and officers, Beneficient and its directors and officers are also covered under the Shared D&O Policies, including though the designation in such policies of BCH and Ben LP as “Additional Parent Companies.” The Shared D&O Policies collectively provide a total of \$155 million of coverage, including \$95 million for coverage of Side A, Side B, or Side C claims and an additional \$60 million for coverage only of Side A claims. Each of the Shared D&O Policies is a “claims made” policy, generally meaning that they provide coverage for claims that were first asserted during the applicable policy period. In addition to paying approximately half of the policy premiums for the Shared D&O Policies, Beneficient acquired tail policies (which provide insurance for an extended reporting period) with respect to the Shared D&O Policies, such that the Shared D&O Policies now provide coverage for claims made by April 14, 2028 with respect to acts occurring prior to April 14, 2022. The Debtors understand that, as of March 7, 2023, an amount of approximately \$9 million has been advanced by the insurance carriers under the Shared D&O Policies in payment or reimbursement of covered defense costs.

As described in more detail in the Initial Debtors’ *Motion for (I) Entry of an Order Modifying the Automatic Stay and Authorizing Use of Estate Property, to the Extent Applicable, to Allow Payment, Reimbursement, and/or Advancement of Defense Costs Under Insurance Policies and (II) Granting Related Relief* [Docket No. 639] (the “Insurance Motion”), the Debtors, with Beneficient, hold two primary comprehensive policies, the Primary D&O Policy and the Primary Company Policy (each as defined in the Insurance Motion). The Primary D&O Policy provides Side A, Side B, and Side C coverage to the Debtors, Beneficient, and their respective former and current officers and directors and certain other parties, for certain losses, including defense costs arising out of covered claims. The Primary Company Policy supplements the Primary D&O Policy by, among other things, providing direct coverage with respect to certain claims made against, and regulatory investigations involving, the Debtors and Beneficient. The Primary D&O Policy and Primary Company Policy together provide coverage up to a set combined policy limit. However, the remaining Shared D&O Policies provide excess coverage (subject to their own terms and conditions) beyond the primary limit. Some of the excess policies in this tower provide Side A coverage only, i.e., they do not cover the obligations of the Debtors or Beneficient, but rather only provide direct coverage to their respective individual directors and officers. Moreover, each of the Shared D&O Policies that also provides Side B and Side C coverage also contains a priority of payment provision that provides that losses for covered claims for which payment is due are payable first to the insured directors and officers.

Shortly before the Initial Petition Date, the Debtors acquired additional D&O Liability Insurance Policies that cover only the Company and its directors and officers (but not Beneficient and its directors and officers) (the “GWG D&O Policies”). The GWG D&O Policies provide a total of \$15,000,000 in coverage for claims relating to acts allegedly committed from and after April 14, 2022 and made by April 14, 2023. As of the date hereof, the Debtors are not aware of any claims covered by or made on the GWG D&O Policies.

(b) *The Insurance Motion*

On July 26, 2022, the Initial Debtors filed the Insurance Motion seeking entry of a comfort order for the insurance companies, which order provided that the automatic stay did not bar the Debtors’ insurance carriers from paying certain defense expenses under the Shared D&O Policies with respect to the SEC Investigation, the Securities Litigation, and actions filed by Paul Capital and other plaintiffs against Beneficient and other non-Debtor parties.

To address the Bondholder Committee’s issues concerning an insurance claim asserted by Willkie Farr against the insurance carriers for \$4.3 million in prepetition defense costs in connection with the SEC Investigation, the Bankruptcy Court entered the D&O Insurance Order on September 7, 2022 (a) directing the insurance carriers to pay to the Debtors the amount of Willkie Farr’s prepetition defense costs; (b) ordering the parties, within 30 days, to reach a stipulation on a rational estimate of Side A-covered defense costs of Willkie Farr, with the Debtors to pay such amount to Willkie Farr; (c) ordering the balance of insurance proceeds *less* Side A-defense costs to be paid to Willkie Farr as a retainer for postpetition work, with such postpetition defense costs to constitute administrative expenses, subject to the Bankruptcy Court’s approval; and (d) reserving the decision as to whether the retainer can be used to pay additional prepetition defense costs of Willkie Farr for a hearing currently scheduled for May 1, 2023. [Docket No. 1576].

On October 6, 2022, the Initial Debtors, Willkie Farr, and the Bondholder Committee stipulated that Willkie Farr’s Side A-covered prepetition defense costs were \$2,268,979.00 and the remainder of the insurance payment, less certain amounts owed to an e-discovery vendor, would be remitted to Willkie Farr to hold as a retainer for security against the nonpayment of its postpetition fees and expenses, subject to further court order as set forth in the September 7, 2022 order. [Docket No. 825]. It is the Debtors’ understanding that, in connection with the foregoing payments and other claims made under the Shared D&O Policies, coverage under the Primary D&O Policy, Primary Company Policy, and the first excess policy layer has been exhausted, triggering coverage under the next subsequent excess policy layer.

(c) *Treatment of the D&O Liability Insurance Policies under the Second Amended Plan*

Under the Second Amended Plan, all of the Debtors’ D&O Liability Insurance Policies and any agreements, documents, or instruments relating thereto, are treated as and deemed to be Executory Contracts. On the Effective Date, pursuant to section 365(a) of the Bankruptcy Code, the Debtors shall be deemed to have assumed all D&O Liability Insurance Policies and any agreements, documents, and instruments related thereto (including tail coverage liability insurance). Entry of the Confirmation Order will constitute the Bankruptcy Court’s approval of

the Debtors' assumption of all such insurance policies, including the D&O Liability Insurance Policies. After the Effective Date, the Wind Down Debtors and the Litigation Trust, as applicable, shall not terminate or otherwise reduce, modify, or restrict in any way the coverage under any D&O Liability Insurance Policy (including such tail coverage liability insurance) in effect as of the Effective Date, including with respect to conduct occurring on or prior to April 20, 2022, and all members, managers, directors, and officers of the Debtors who served in such capacity at any time prior to the Effective Date of the Second Amended Plan and who are covered by any such policy shall be entitled to the full benefits of any such policy for the full term of such policy regardless of whether such members, managers, directors, and/or officers remain in such positions after the Effective Date. Without limiting the generality of the other provisions of the Second Amended Plan, and following such assumption, all right, title, and interest of the Debtors (and of the Wind Down Debtors and the Litigation Trust, as applicable) in and to any D&O Liability Insurance Policy (including any such tail coverage liability insurance) in effect as of the Effective Date covering claims relating to conduct occurring on or prior to April 20, 2022 shall be deemed assigned and fully transferred on the Effective Date to the Litigation Trust and shall constitute Initial Litigation Trust Assets for all purposes.

H. Litigation Matters

The Company is party to certain lawsuits, legal proceedings, collection proceedings, and claims arising out of their business operations. With certain exceptions, the filing of the Chapter 11 Cases operates as a stay with respect to the commencement or continuation of litigation against the Debtors that was or could have been commenced before the commencement of the Chapter 11 Cases. In addition, the Debtors' liability with respect to litigation stayed by the commencement of the Chapter 11 Cases generally is subject to discharge, settlement, and release upon confirmation of a plan under chapter 11, with certain exceptions. Therefore, certain litigation Claims against the Debtors may be subject to discharge in connection with the Chapter 11 Cases.

The following sets forth certain developments with respect to litigation matters following the Initial Petition Date.

1. Securities Litigation

As set forth above, as of the Initial Petition Date, the Securities Litigation was in the pleading stage. On May 6, 2022, in the Bankruptcy Court, the proposed lead plaintiffs in the Securities Litigation, Thomas Horton and Frank Moore, filed the *Unopposed Motion for Relief from the Automatic Stay to (A) Appoint Lead Plaintiffs in Securities Class Action, (B) Permit Lead Plaintiffs to Serve and Enforce Third-Party Subpoenas, and (C) Take Related Actions* [Docket No. 201]. This motion was granted on May 31, 2022, modifying the automatic stay for the limited purpose of allowing the appointment of the lead plaintiffs in the Securities Litigation and allowing the lead plaintiffs to serve a limited number of third-party subpoenas. [Docket No. 321]. The Northern District of Texas entered its *Order Appointing Lead Plaintiff and Approving Lead Plaintiff's Selection of Counsel* on August 5, 2022, appointing Thomas Horton and Frank Moore as lead plaintiffs, and approving their selection of the law firms of Girard Sharp LLP and Malmfeldt Law Group P.C. as lead counsel for that dispute. Otherwise, as of the present date, the Securities Litigation has been stayed.

2. Claims Objections

Since the Initial Petition Date and as of April 20, 2023, parties in interest have filed 5,402 Proofs of Claim against the Estates. The Debtors continue to evaluate Claims that have been asserted against their Estates, and whether, in connection with such evaluation, to object to any such Claims (either in full or in part). If the Second Amended Plan is confirmed, the Debtors will establish a Disputed Claims Reserve and place in such reserve an amount equal to the Disputed Claims Reserve Amount for distributions on account of Claims that may be Disputed (including Claims that the Debtors, Wind Down Debtors or other parties in interest object to). The Disputed Claims Reserve Amount means the amount of assets determined prior to the Effective Date by the Debtors, in consultation with the Creditor Proponents, that would likely have been distributed to the Holders of all applicable Disputed Claims against the Debtors as if such Disputed Claims against the Debtors had been Allowed Claims against the Debtors on the Effective Date, with the amount of such Allowed Claims to be determined, solely for the purposes of establishing reserves and for maximum distribution purposes, to be: (a) the lesser of (i) the asserted amount of each Disputed Claim against the Debtors as scheduled by the Debtors or, if and solely to the extent a non-duplicative Proof of Claim was Filed in an asserted amount greater than the scheduled amount, the asserted amount Filed with the Bankruptcy Court as set forth in such non-duplicative Proof of Claim or as provided by the parties to the Debtors as further information with respect to the Proof of Claim, and (ii) the amount, if any, estimated by the Bankruptcy Court pursuant to section 502(c) of the Bankruptcy Code or ordered by other order of the Bankruptcy Court; or (b) the amount otherwise agreed to by the Debtors and the Holder of such Disputed or unliquidated Claim for reserve purposes. For more information, see Article VII.F of the Second Amended Plan.

3. Bondholder Committee Standing Motion & Proposed Complaint

On December 15, 2022, following an extensive investigation, the Bondholder Committee filed a motion for standing to prosecute certain Causes of Action on behalf of the Debtors' Estates [Docket No. 1250] (the "Standing Motion"). Pursuant to the Standing Motion, the Bondholder Committee seeks the Bankruptcy Court's authorization to file a complaint against dozens of parties including Beneficient and various entities related to Beneficient, such as HCLP Nominees L.L.C., directors and officers of Beneficient including the Chief Executive Officer Bradley K. Heppner, former GWGH directors and officers, broker dealers and other individuals and entities, a copy of which is attached as an exhibit to the Standing Motion [Docket No. 1250-1] (the "Proposed Committee Complaint"),⁵⁵ and to prosecute the Causes of Action contained therein on behalf of and for the benefit of the Debtors' Estates. **The Standing Motion with the Proposed Committee Complaint may be found at <https://www.donlinrecano.com/gwgbondholders>.**

The Proposed Committee Complaint purports to assert 23 separate Causes of Action for fraudulent transfers, breach of fiduciary duties, unjust enrichment, and recovery of improper

⁵⁵ The Standing Motion and Proposed Committee Complaint were initially filed under seal, but were unsealed and released in unredacted form on February 1, 2023.

dividends, which Causes of Action the Bondholder Committee believes are viable and valuable. Among other things, the Proposed Committee Complaint seeks to:⁵⁶

- Avoid and recover \$65 million of advances made by GWGH under the LiquidTrust Promissory Note from the applicable LiquidTrusts or subsequent transferees;
- Avoid the June 2019 Acquisition of Ben LP limited partnership units from the Essex Defendants (as defined in the Proposed Committee Complaint) and recover the \$10 million in consideration paid by GWGH therefor;
- Avoid the 2019 Capital Contribution, in which GWGH purchased Ben LP common units and a Preferred Series A Subclass Unit 1 Account of BCH, and recover the \$79 million in contributions made by GWGH pursuant thereto;
- Avoid and recover \$42 million in commissions that were paid to certain of the Broker Dealers;
- Avoid the 2020 and 2021 Capital Contributions in which GWGH purchased Preferred Series C for \$130.2 million and \$14.8 million in the years ending 2020 and 2021, respectively, and recover the \$145 million in contributions made by GWGH pursuant thereto;
- Avoid the Beneficent Separation Transactions and recover the more than \$202 million in debt under the Commercial Loan Agreement that was satisfied by equity in Beneficent in connection therewith (the LiquidTrust Promissory Note, June 2019 Acquisition, 2019 Capital Contribution, 2020 and 2021 Capital Contributions, and Beneficent Separation Transactions, collectively, the “Committee Challenged Transactions”); and
- Seek recovery for breaches of fiduciary duty against directors and officers of GWGH.

The Proposed Committee Complaint also seeks to (i) hold former directors and officers of GWGH, including Bradley K. Heppner, Thomas O. Hicks, Bruce W. Schnitzer, Dennis P. Lockhart, and Peter T. Cangany, among others, liable for alleged breaches of fiduciary duties relating to the Committee Challenged Transactions and other transactions, (ii) avoid and recover commissions that were paid to certain Broker Dealers,⁵⁷ (iii) hold Beneficent, Mr. Heppner, and other parties liable for unjust enrichment in connection with the Committee Challenged Transactions and other transactions, and (iv) recover from former directors of GWGH \$25.7 million on account of a 2018 special dividend they authorized to be paid to GWGH shareholders purportedly in violation of Delaware law.

⁵⁶ The below is a summary of the causes of action asserted in the Standing Motion and Proposed Committee Complaint and should not be viewed as limiting or in any other way constricting the allegations outlined by the Bondholder Committee.

⁵⁷ The Ad Hoc Broker/Dealer Committee disputes that colorable claims for the avoidance and recovery of commissions paid to certain Broker Dealers exists.

The Standing Motion also attached a letter to LBM in which the Committee asserted that it had “uncovered ample evidence that the Committee has colorable direct claims in respect of the Seller Trust L Bonds for recharacterization, equitable subordination and/or mandatory subordination.”⁵⁸

The Debtors oppose the Standing Motion on, among other things, the grounds that the Investigations Committee is actively pursuing the colorable Causes of Action belonging to the Debtors. Unless otherwise resolved in a settlement approved by the Bankruptcy Court, all Retained Causes of Action – including the Causes of Action that are the subject of the Standing Motion – will be retained by the Litigation Trust and prosecuted or settled by the Litigation Trust for the benefit of all stakeholders in accordance with the Second Amended Plan.

A hearing on the Standing Motion had originally been scheduled for March 10, 2023. However, pursuant to the Mediation Agreement, the Bondholder Committee agreed to adjourn the hearing on the Standing Motion to the earlier of (a) the date of the Confirmation Hearing, and (b) June 23, 2023 (or the first available date on the Bankruptcy Court’s calendar). The deadline to object to the Standing Motion has been extended to 4:00 p.m. (prevailing Central Time) on the day that is seven days prior to the Confirmation Hearing.

In an effort to resolve the *Limited Objection of Brad K. Heppner to Motion to Approve Disclosure Statement Relating to Second Amended Plan* [Docket No. 1577], the Debtors have agreed to include the following statement:

Both Mr. Heppner and Beneficient oppose the Standing Motion and vigorously dispute the allegations in the Proposed Committee Complaint. Beneficient filed the *Objection of the Beneficient Company Holdings, L.P. and the Beneficient Company Group, L.P. to the Motion of the Official Committee of Bondholders of GWG Holdings Inc., et al., for Standing to Prosecute Causes of Action on Behalf of the Debtors’ Estates* [Docket No. 1451]. Separately, Mr. Heppner filed the *Objection of Brad K. Heppner to Motion of Official Committee of Bondholders of GWG Holdings Inc., et al., for Standing to Prosecute Estate Causes of Action on Behalf of Debtors’ Estates and Joinder in Objection of Beneficient Company Holdings, L.P. and the Beneficient Company Group, L.P.* [Docket No. 1457]. These objections argue, among other things, that the Proposed Committee Complaint and its Causes of Action are legally and factually flawed.

I. Investigations

1. The SEC Investigation

As set forth above and in the First Day Declaration, the SEC Investigation was commenced prior to the Initial Petition Date and remains ongoing. The Company has complied and cooperated with the investigation. On June 15, 2022, the SEC commenced a lawsuit against a certain Broker Dealer, along with certain individuals affiliated with it (but not against the Company) alleging

⁵⁸ LBM disputes, (1) that colorable claims for recharacterization, equitable subordination, and/or mandatory subordination exist against the Seller Trust L Bonds, and (2) that the Bondholder Committee holds such claims as direct claims.

violations of the SEC's Regulation Best Interest in connection with such Broker Dealer's sale of Public L Bonds.

Prior to the commencement of the Chapter 11 Cases, the Company retained Willkie Farr as Special Counsel in connection with the SEC Investigation and other matters arising under federal securities laws. The Initial Debtors sought and received Bankruptcy Court approval to retain Willkie Farr in the Chapter 11 Cases in connection with the SEC Investigation. [Docket Nos. 268, 450].

On September 21, 2022, the Initial Debtors and the SEC entered into stipulations agreeing to (1) extend the bar date for the SEC to file a Proof of Claim to November 30, 2022, and (2) set November 30, 2022 as the date by which the SEC is required to file a complaint to determine dischargeability of debt pursuant to section 1141(d)(6) of the Bankruptcy Code, subject to further extensions as may be agreed by the parties. The stipulations were so-ordered by the Bankruptcy Court on September 23. [Docket No. 786 and 787].

2. Formal and Information Discovery in Connection with Certain Investigations

As described above, GWGH's board formed the Investigations Committee to, among other things, conduct the Independent Investigation. Concurrent with the Investigations Committee's work, the Bondholder Committee has also undertaken its own investigation into certain alleged claims and causes of action on behalf of the Debtors' Estates. The Debtors have received multiple requests for information, produced their directors and officers for depositions, and gathered and produced a multitude of materials to various parties who have requested such information. The Debtors' document production is ongoing. Throughout the Chapter 11 Cases, the Debtors have engaged with the Independent Committees and the Bondholder Committee by holding weekly meetings and producing tens of thousands of documents to facilitate the Investigations Committee's and Bondholder Committee's respective investigations.

The Debtors and the Bondholder Committee have worked to resolve discovery issues, and have entered into numerous stipulations to that effect. [Docket Nos. 621, 631]. In particular, while the Debtors maintained that discovery requests relating to the SEC Investigation did not relate to any issue or motion before the Bankruptcy Court, in response to discovery motion practice filed by the Bondholder Committee [Docket No. 465], the Debtors and the Bondholder Committee reached an agreement on a process for judicial resolution of the outstanding discovery disputes among the parties wherein the parties agreed that the Debtors would provide to the Bondholder Committee, on a professional-eyes-only basis, certain materials the Debtors had previously produced to the SEC as part of the SEC Investigation. The Debtors and the Bondholder Committee also agreed that (a) all other outstanding requests will be responded to, with any questions about the scope of production discussed, in a meet and confer process; and (b) a set of streamlined procedures would apply to resolving disputes arising from such discovery. These agreements were memorialized in a stipulation and protective order that was approved by the Bankruptcy Court on July 22, 2022. [Docket Nos. 632, 753].

3. Status and Progress of Independent Investigation

As set forth above, pursuant to the Resolutions, the Investigations Committee was delegated the exclusive authority to conduct an internal investigation with respect to, among other things, any potential claims and Causes of Action that arise under or relate to any transactions, relationships, or conduct involving the Company, any of its current and former subsidiaries and affiliates, and any third party, including Beneficient. The Independent Investigation remains ongoing as of the date hereof, but is substantially complete.

In the course of conducting the Independent Investigation, and at the direction of the Investigations Committee, Katten and Province collected and reviewed documents and information from (among other sources) the Debtors, the Debtors' advisors, Beneficient, and certain current and former directors and officers of GWGH, including, among other documents, copies of board materials and minutes, corporate governance documents, intercompany agreements, financial and accounting information, and internal company communications. To date, Katten and Province have received and reviewed over 350,800 documents. Katten has conducted 33 interviews and eight depositions, including interviews and depositions of members of the Debtors' management team, current and former directors, and current and former legal and financial professionals involved with the Company and Beneficient. To minimize cost and avoid duplication of effort, Katten attended additional interviews conducted by the Bondholder Committee, some of which included persons already interviewed by Katten. Katten has also collaborated regularly with the Bondholder Committee's advisors (including in weekly meetings between Katten and the Bondholder Committee's advisors), sought and obtained input from the Bondholder Committee's advisors concerning potential claims and matters of concern to the Independent Investigation, and diligently pursued avenues of inquiry suggested by the Bondholder Committee's advisors.

Pursuant to the Independent Investigation, Katten and Province analyzed potential claims and Causes of Action held by the Debtors' Estates relating to, among other things, (i) the Company's prepetition investments in Beneficient, including the transactions described in Article IV.A.2.b of this Disclosure Statement, among others; (ii) Beneficient's use of funds received from the Company; (iii) the Beneficient Separation Transactions, as described in Article IV.A.2.b of this Disclosure Statement; (iv) the Company's prepetition transactions involving the DLP Senior Secured Parties, including the transactions described in Article V.B of this Disclosure Statement; (v) the Shared Services Agreement; (vi) the Company's prepetition interests in FOXO; and (vii) public disclosures by the Company concerning certain material transactions and events, including certain public disclosures related to the resignation of certain former directors of GWGH, as further described below.

As discussed in further detail in Article VII.4 of this Disclosure Statement, the Investigations Committee informed the GWGH board of certain issues that it became aware of due to the Independent Investigation, which the GWGH board acted upon.

In addition to this matter, the Investigations Committee is continuing to pursue Causes of Action in accordance with the authority it has been given by the GWGH board. The Investigations Committee has uncovered several colorable Causes of Action belonging to the Debtors that it is actively pursuing. Unless otherwise resolved in a settlement approved by the Bankruptcy Court,

in accordance with the Mediation Agreement, the Causes of Action will be retained by the Litigation Trust and prosecuted or settled by the Litigation Trust for the benefit of all stakeholders in accordance with the Second Amended Plan.

4. Filing of Amended 8-K and Related Matters

GWGH is subject to certain reporting requirements pursuant to the United States Securities Exchange Act of 1934, as amended (the “Securities Exchange Act”), including filing current reports on a Form 8-K following the occurrence of certain events. The resignation of directors from the board of directors is an event that triggers an obligation to file a Current Report on Form 8-K.

On March 6, 2021, Roy W. Bailey, Daniel P. Fine, and Jeffrey N. MacDowell (the “Resigning Directors”) resigned from the GWGH board of directors (as constituted at that time, the “2021 Board”). The 2021 Board consisted of Bradley K. Heppner, Peter T. Cangany, Jr., David F. Chavenson, David H. de Weese, Thomas O. Hicks, Dennis P. Lockhart, Bruce W. Schnitzer, and the Resigning Directors. Each of the Resigning Directors had been the members of a special committee of the 2021 Board (the “2021 Special Committee”), which was formed to review and approve or reject potential transactions with Beneficient. On March 11, 2021, GWGH filed a Current Report on Form 8-K (the “Original 8-K”) to report, among other matters, the resignations of the Resigning Directors. The Original 8-K stated that the resignations of Messrs. Bailey, Fine and MacDowell “were not due to any disagreement with the Company known to an executive officer of the Company on any matter relating to the operations, policies or practices of the Company.”

During the course of the Independent Investigation, the Investigations Committee became aware of information that caused it to conclude that the Original 8-K incorrectly stated that the resignations were not due to any disagreement with GWGH. Promptly thereafter, the Investigations Committee informed the board of directors of GWGH (as constituted at that time, the “2022 Board”), which then consisted of Murray T. Holland, Timothy L. Evans, David F. Chavenson, David H. de Weese, and the members of the Investigations Committee, of certain information the Investigations Committee determined regarding the accuracy of the statements in the Original 8-K, which after review and consideration, led the 2022 Board to determine and conclude that the resignations provided by the Resigning Directors resulted from disagreements with the Company relating to certain operations, policies and practices of the Company. Specifically, the Investigations Committee informed the 2022 Board that, at the time of the resignations, the Resigning Directors had objected to certain terms and parameters of a proposed investment the Company was considering in a Preferred Series C Unit Account of Ben (the “Pref C Investment”), and certain other related matters, which had been submitted to the 2021 Special Committee for review and approval pursuant to resolutions of the 2021 Board. Prior to their resignations, the Resigning Directors made their objection to the Pre C Investment known to GWGH’s Chief Executive Officer and the Chief Financial Officer through written and oral communications. The Investigations Committee further informed the 2022 Board that, after the objections of the Resigning Directors to the Pref C Investment were made known to the Company, on March 3, 2021, the then-Chairman of the 2021 Board, Bradley K. Heppner, called for a special meeting of the 2021 Board to consider certain “urgent” matters concerning GWGH’s “funding of Ben.” The Investigations Committee further informed the 2022 Board that, at a March 4, 2021

special meeting of the 2021 Board, while the disagreements concerning the Pref C Investment remained unresolved (a fact that may not have been known to the full 2021 Board), the 2021 Board voted to dissolve the 2021 Special Committee and voted to confirm that the Pref C Investment could be made without 2021 Special Committee approval. The 2022 Board has determined and concluded that these disagreements caused, in whole or in part, the Resigning Directors' resignations on March 6, 2021. At the time of the Resigning Directors' resignations, the disagreements remained outstanding, which was known to, at least, the Chief Executive Officer of GWGH.

As a result of these determinations, the 2022 Board resolved to file, and on November 14, 2022, GWGH filed, an amended Form 8-K (the "Amended 8-K"). The Amended 8-K included two exhibits, specifically: (i) the written resignation letters, delivered by the Resigning Directors on March 6, 2021, to the then-Chairman of the 2021 Board, Bradley K. Heppner, and the Chief Executive Officer of GWGH, Murray T. Holland, and (ii) certain e-mail correspondence, dated March 9, 2021, from the Chief Executive Officer and sent to the Resigning Directors, previewing certain language proposed to be included in the Original 8-K regarding the circumstances of the resignations of the Resigning Directors, and subsequent e-mail correspondence from Mr. Fine, dated March 10, 2022 and sent to the Company's Chief Executive Officer on behalf of himself and the other Resigning Directors.

Throughout this time period, Murray T. Holland served as Chief Executive Officer of GWGH and Timothy L. Evans served as Chief Financial Officer of GWGH. On November 13, 2022, Murray T. Holland resigned as President and Chief Executive Officer of GWGH and on November 14, 2022, Timothy L. Evans resigned as Chief Financial Officer of GWGH, in each case, effective as of the date of such resignation. Shortly before and at the time of their resignations, Mr. Holland and Mr. Evans expressed their disagreement with the Investigations Committee's findings with respect to the inaccuracy of the 2021 8-Ks and the decision to file amended 8-Ks.⁵⁹ However, Messrs. Holland and Evans did not immediately resign from their positions as directors of GWGH nor from their roles with respect to certain other subsidiaries of GWGH. GWGH issued a press release regarding the resignations of Messrs. Holland and Evans on November 14, 2022.

As a result of these developments, the Debtors requested a status conference to inform the Bankruptcy Court of the matters relating to the filing of the Amended 8-K and resignations of Messrs. Holland and Evans as officers of GWGH. At such status hearing, which was held on November 14, 2022, the Bankruptcy Court scheduled a hearing on November 17, 2022, to determine whether one or more directors of GWGH who acquiesced in or approved of the preparation of the Original 8-K should be removed from the GWGH board of directors, which hearing was rescheduled to December 1, 2022 upon the motion of Mr. Holland. On November 14, 2022, the Bankruptcy Court entered the *Order Temporarily Suspending the Authority of the Board*

⁵⁹ The basis for Mr. Holland's disagreement is reflected in his resignation letter, which was filed as an exhibit to the Company's December 2, 2022 8-K, available at <https://www.sec.gov/Archives/edgar/data/1522690/000119312522296756/d415864dex172.htm>. Mr. Evans communicated his concerns about the process associated with the Investigations Committee's review of the Original 8-K, the Investigations Committee's findings regarding the Original 8-K, and the 2022 Board's decision to file the Amended 8-K to the 2022 Board in a November 13, 2022 letter to the 2022 Board [Docket No. 1594]. GWGH's Form 8-K filed November 22, 2022, which attached Mr. Evans' November 16, 2022 2022 Board resignation letter, also noted Mr. Evans' disagreement.

of *Directors of GWG Holdings, Inc.* [Docket No. 1061], which (i) prohibited the Debtors from making any monetary transfer except for (a) a monetary transfer approved in writing in advance by Jeffrey S. Stein, or (b) a monetary transfer made in the Debtors' ordinary course of business in an amount of less than \$5,000, (ii) prohibited the Debtors from making any non-monetary transfer, unless the non-monetary transfer has been approved in advance in writing by Jeffrey S. Stein, and (iii) suspended all of the powers of the GWGH board of directors to act on behalf of the Debtors, or to direct the Debtors' officers, agents, attorneys or employees, pending further order of the Bankruptcy Court. [Docket No. 1061].

On November 15, 2022, David H. de Weese resigned from the GWGH board of directors, and on November 16, 2022, Timothy L. Evans and David F. Chavenson resigned from the GWGH board of directors. On November 25, Murray T. Holland resigned from the GWGH board of directors.⁶⁰ As all directors of GWGH who were on the board of directors at the time of the preparation of the Original 8-K had resigned from the GWGH board of directors, the hearing rescheduled to December 1, 2022 did not go forward on the matter and the Bankruptcy Court entered the *Order Reinstating the Board of Directors* [Docket No. 1137], reinstating the powers of the Board of Directors of GWGH, comprising Mr. Jeffrey S. Stein and Mr. Anthony R. Horton.

As a result of these developments, the 2022 Board appointed Jeffrey S. Stein as President and Chief Executive Officer of GWGH. The Current Board also granted Mr. Stein the authority to hire a new Chief Financial Officer. On December 21, 2022 the Debtors filed the *Debtors' Motion for Entry of an Order Confirming Expansion of Engagement of FTI Consulting, Inc. and Designation of Michael A. Tucker as Interim Chief Financial Officer, and Granting Related Relief* [Docket No. 1273] (the "CFO Retention Motion"). On January 17, 2023, the Bankruptcy Court entered an order approving the CFO Retention Motion, [Docket No. 1353] designating Michael A. Tucker as interim CFO effective as of December 10, 2022.

J. Compensation Motion

On January 25, 2023, the Debtors filed the *Debtors' Motion for Entry of an Order Approving Amendments to Consulting Agreement with Jeffrey S. Stein and Independent Director Agreement with Anthony R. Horton and Granting Related Relief* [Docket No. 1392] (the "Compensation Motion") which sought to, among other things (a) accurately reflect Mr. Stein's expanded roles and compensate him accordingly, (b) accurately reflect Mr. Horton's expanded role, given the resignations of the Non-Management Directors, and to compensate Mr. Horton

⁶⁰ On November 21, 2022, the Debtors filed the Second Supplemental Declaration of Thomas S. Kiriakos in Support of the Debtors' Application for Entry of an Order Authorizing the Retention and Employment of Mayer Brown LLP As Attorneys for the Debtors and Debtors in Possession [Docket No. 1091] (the "Second Supplemental Declaration"). As described in the Second Supplemental Declaration, Mayer Brown rendered services to the Debtors prior to the commencement of the Chapter 11 Cases of the Initial Debtors, including relating to GWGH's audited statements and SEC disclosures (including with respect to the Original 8-K). Out of an abundance of caution, Mayer Brown removed itself from the GWGH Board's ultimate deliberations regarding the applicable SEC disclosures, and Jackson Walker LLP advised and will continue to advise (to the exclusion of Mayer Brown) the Debtors and the GWGH Board with respect to any issues regarding the Original 8-K, the Amended 8-K, the treatment of certain officers and directors, as well as any matter that relates directly or follows from the foregoing issues. In addition, and also out of an abundance of caution, a formal screen was put in place to screen those individuals who provided prepetition services to the Debtors in connection with SEC disclosures from any further role in the Chapter 11 Cases.

accordingly. On April 17, 2023, in connection with the mediation, the Debtors, the Bondholder Committee, and LBM, among other parties, entered into the Compensation Motion Stipulation, the terms of which are described in Article II.B.4 of this Disclosure Statement.

VII. SUMMARY OF KEY TERMS AND CONDITIONS OF THE SECOND AMENDED PLAN

A. Wind Down Trust

1. Wind Down Trust Generally

The Confirmation Order shall provide that, upon the occurrence of the Effective Date, the Wind Down Trust shall be deemed established in accordance with the Wind Down Trust Agreement and the Second Amended Plan. On the Effective Date, the Wind Down Trust shall commence the taking of all necessary steps to wind down the business affairs of the Debtors.

The Wind Down Trust Assets shall be deemed disbursed by the Debtors and transferred to the Wind Down Trust on the Effective Date, the proceeds of which shall be distributed in accordance with the waterfall set forth in Article IV.H of the Second Amended Plan. The powers, authorities, responsibilities, and duties of the Wind Down Trust and the Wind Down Trustee are set forth in and shall be governed by the Second Amended Plan and the Wind Down Trust Agreement. The Wind Down Trust Agreement, which shall be part of the Plan Supplement, shall be consistent with the Second Amended Plan and shall contain provisions customary to trust agreements utilized in comparable circumstances, including, without limitation, any and all provisions necessary to ensure the continued treatment of the Wind Down Trust as a grantor trust. The Wind Down Trust Agreement may provide powers, duties, and authorities in addition to those explicitly stated herein, but only to the extent that such powers, duties, and authorities do not affect the status of the Wind Down Trust as a “liquidating trust” for United States federal income tax purposes or as an entity that can fall within the exception from registration in Section 7 of the 1940 Act for activities of companies that are merely incidental to their dissolution.

In accordance with the Second Amended Plan, the Wind Down Trust’s sole purpose is to liquidate the Wind Down Trust Assets with a view towards maximizing the value of such assets for the benefit of New WDT Interest holders, and promptly distributing such liquidation proceeds (in accordance with the provisions of the Second Amended Plan) to New WDT Interest holders. The Wind Down Trust will have no going concern operations and will not be permitted to continue or engage in the conduct of a trade or business or to make any investments (other than holding, on a temporary basis (pending distribution to holders or use for payment of permitted expenses) certain short-term, high-quality cash equivalents (as set out in the Wind Down Trust Agreement); instead the Wind Down Trust’s activities will be limited to those reasonably necessary to, and consistent with, the Wind Down Trust’s liquidating purpose and reasonably necessary to conserve, protect, and/or maximize the value of the Wind Down Trust Assets and provide for the orderly liquidation thereof. The Wind Down Trust Agreement shall contain appropriate provisions for monetizing the Wind Down Trust Assets in an orderly fashion, subject to the Wind Down Trustee’s reasonable business judgment. The Wind Down Trustee, on behalf of the Wind Down Trust, will have discretion to enter into, consummate, settle, or otherwise resolve any transaction or dispute with respect to each of the Wind Down Trust Assets that have an economic value of less than \$5

million (in the Wind Down Trustee's good faith determination) as of the date of the consummation, settlement, or resolution of such transaction or dispute. The Wind Down Trustee will submit all other matters to the Bankruptcy Court for approval after notice and an opportunity for a hearing.

The Wind Down Trust will have an initial term of three years, which, subject to applicable law, may be extended by the Wind Down Trustee Filing a motion with the Bankruptcy Court prior to the expiration of the existing term and obtaining Bankruptcy Court approval of an extension for up to two years per request (subject, in each instance, to reasonable due consideration being given to implications of tax law and other applicable law of the proposed extension of the term of the Wind Down Trust). The Wind Down Trustee and the Litigation Trustee will cooperate and confer to ensure that the Wind Down Trust does not terminate prior to the Litigation Trust.

2. Transfer of Assets Into the Wind Down Trust

Except as otherwise provided in the Second Amended Plan or the Confirmation Order, on the Effective Date, the Wind Down Trust Assets shall be deemed transferred to the Wind Down Trust by the Debtors, such assets shall vest in the Wind Down Trust on such date, to be administered by the Wind Down Trustee in accordance with the Second Amended Plan and the Wind Down Trust Agreement, and the Debtors and their Estates shall have no further interest with respect to the Wind Down Trust Assets. The Wind Down Trust Assets will vest in the Wind Down Trust free and clear of all Liens, Claims, Interests, encumbrances, etc. The act of transferring the Wind Down Trust Assets, as authorized by the Second Amended Plan, shall not be construed to destroy or limit any such assets or rights or be construed as a waiver of any right, and such rights may be asserted by the Wind Down Trustee as if the asset or right was still held by the relevant Debtor.

The Wind Down Trustee shall have the authority to create additional sub-trusts within (or other subsidiary Entities under) the Wind Down Trust, which may have a separate legal existence, but which shall be considered sub-trusts (or other subsidiary Entities under, as applicable) of the Wind Down Trust.

3. Wind Down Trustee

The Wind Down Trustee shall have the sole authority to make decisions and take action with respect to the Wind Down Trust in accordance with the terms of the Second Amended Plan and the Wind Down Trust Agreement. The Wind Down Trustee shall be the successor to and representative of the Estates of the Debtors within the meaning of section 1123(b)(3)(B) of the Bankruptcy Code. Following the Effective Date, the Wind Down Trust and the Wind Down Trustee shall be deemed a party in interest with standing to appear in the Chapter 11 Cases and object to any pleading Filed thereafter; *provided, however*, such standing and right to object does not alter the respective rights or responsibilities of the Wind Down Trustee or the Litigation Trustee under the Second Amended Plan, the Wind Down Trust Agreement, or the Litigation Trust Agreement, alter any governing approval standard under applicable law, or otherwise limit the ability of any party with standing to respond to pleadings Filed, or objections raised, by the Wind Down Trustee. The powers, rights, and responsibilities of the Wind Down Trustee shall be specified in the Second Amended Plan and the Wind Down Trust Agreement, and shall include, within the confines of the stated purpose of the Wind Down Trust, taking all appropriate actions

to maximize the value of and monetize the Wind Down Trust Assets for the benefit of stakeholders, whether by accepting, preserving, receiving, collecting, administering, selling, liquidating, or transferring, as applicable, the Wind Down Trust Assets. All determinations with respect to the monetization of the Wind Down Trust Assets, including the Wind Down Trust's interests in Beneficient and FOXO, will be subject to the reasonable business judgment of the Wind Down Trustee, subject to compliance with any applicable lock-up agreement or securities law requirements and subject to the requirement that the Wind Down Trustee seek and obtain Bankruptcy Court approval of any transaction with an economic value of \$5 million or more, as set forth in the Second Amended Plan.

For the avoidance of doubt, the Wind Down Trustee may conduct sales or liquidations of Wind Down Trust Assets on any terms it deems reasonable, without further order of the Bankruptcy Court (except as provided in the Second Amended Plan). The Wind Down Trustee may also abandon any Wind Down Trust Assets that the Wind Down Trustee determines in its reasonable discretion to be of *de minimis* value or burdensome to the Wind Down Trust.

The Wind Down Trustee shall use the Wind Down Amount (and any subsequent monetization proceeds from the Wind Down Trust) to fund all expenses related to its duties under the Second Amended Plan. The Wind Down Trustee, on behalf of the Wind Down Trust, may employ, without further order of the Bankruptcy Court, professionals (including professionals previously engaged in the Chapter 11 Cases), employees, or other independent contractors to assist in carrying out its duties under the Second Amended Plan, including the Wind Down Trust Agreement, and may compensate and reimburse the expenses of these professionals, employees, or other independent contractors based upon the nature of the work performed by such parties without further order of the Bankruptcy Court, subject to any limitations and procedures established by the Wind Down Trust Agreement.

4. Reports to Be Filed by the Wind Down Trust

Following the Effective Date, and during the existence of the Wind Down Trust, the Wind Down Trust shall File with the Bankruptcy Court (and provide to any other party entitled to receive any such report pursuant to the Wind Down Trust Agreement), within 90 days after the end of each calendar year during the term of the Wind Down Trust, and within 45 days after the end of each calendar quarter during the term of the Wind Down Trust (other than the fourth quarter) and as soon as practicable upon termination of the Wind Down Trust, the Wind Down Trustee shall make available on its website, a written report including: (a) financial statements of the Wind Down Trust for such period, and, if the end of a calendar year, an unaudited report (which may be prepared by an independent certified public accountant employed by the Wind Down Trustee) reflecting the result of such agreed-upon procedures relating to the administration of the Wind Down Trust as proposed by the Wind Down Trustee; (b) a summary description of any action taken by the Wind Down Trust which, in the judgment of the Wind Down Trustee, materially affects the Wind Down Trust; (c) a description of the progress of liquidating the Wind Down Trust Assets and making distributions to the holders of the New WDT Interests, which description shall include a written report detailing, among other things, the status of the equity interests in Beneficient and FOXO that are held by the Wind Down Trust, the status of Portfolio Co., the status of the Litigation Trust, the proceeds recovered as of the relevant date with respect to assets of the Wind Down Trust or any of the foregoing, and the distributions made by the Wind Down Trust as

of the relevant date; and (d) any other material or significant information relating to the Wind Down Trust Assets and the administration of the Wind Down Trust deemed appropriate to be disclosed by the Wind Down Trustee. In addition, the Wind Down Trust shall provide unaudited financial statements to each holder of the New WDT Interests on a quarterly basis (which may be quarterly operating reports Filed with the Bankruptcy Court). The Wind Down Trustee may post any such report on a website maintained by or on behalf of the Wind Down Trustee and electronically File it with the Bankruptcy Court in lieu of actual notice to each holder of New WDT Interests (unless required by law).

Notwithstanding the foregoing, so long as the Wind Down Trust files periodic reports with the SEC pursuant to Section 13(a) or Section 15(d) of the Securities Exchange Act, the Wind Down Trustee shall be deemed to have satisfied its obligations set forth in the preceding paragraph by filing such periodic reports with the SEC, posting a copy of such reports on a website maintained by or on behalf of the Wind Down Trustee, and Filing a copy of such reports with the Bankruptcy Court.

5. 1940 Act Matters

The implementation of the Second Amended Plan and the Wind Down Transactions, *inter alia*, via the creation and administration of the Wind Down Trust, the Portfolio Co. and the Litigation Trust, is intended to enable the Wind Down Trust and the Debtors to fall within an exception to registration for companies that are dissolving, in accordance with Section 7 of the 1940 Act and the SEC staff's guidance regarding the same (the "Liquidating Company Exception"). In the event that the Wind Down Trustee determines in its sole and absolute discretion at any time that, notwithstanding such remedial actions undertaken or to be undertaken by the Wind Down Trust and/or the Debtors pursuant to the provisions of the Second Amended Plan, the Wind Down Trust and the Debtors nonetheless are or will be unable to comply with or otherwise qualify for the Liquidating Company Exception or any other exception to or an exemption from registering under the 1940 Act, the Wind Down Trustee shall have the sole discretion and authority to develop another strategy to comply with or otherwise qualify under an exception to or exemption from such requirements of the 1940 Act. If it becomes necessary for 1940 Act compliance purposes to change the organization, operations and/or activities of the Wind Down Trust, the Wind Down Trustee will attempt to do so in a way to preserve the economic benefits of ownership of Wind Down Trust to the maximum extent possible.

B. Litigation Trust

1. Litigation Trust Generally

The Litigation Trust will be established on the Effective Date to retain and hold all Retained Causes of Action, the proceeds of which shall be deemed distributed to the Wind Down Trust for ultimate distribution by or at the direction of the Wind Down Trustee in accordance with the waterfall set forth in Article VI.C of the Second Amended Plan. On the Effective Date, the Initial Litigation Trust Assets shall be deemed transferred to the Litigation Trust by the Wind Down Trust and will vest in the Litigation Trust free and clear of all Liens, Claims, interests, encumbrances, etc., with all reversionary and beneficial interests in the Litigation Trust to be held by the Wind Down Trust, subject to the waterfall set forth in Article VI.C of the Second Amended Plan. The

sole beneficiary of the Litigation Trust will be the Wind Down Trust (or the Wind Down Trustee on behalf of the Wind Down Trust, to the extent provided by applicable law), and all proceeds of the Litigation Trust distributed to the Wind Down Trust on account of such reversionary interest shall be for the sole purpose of distributions to the holders of the New WDT Interests issued by the Wind Down Trust; *provided, however*, such proceeds may be otherwise retained and used by the Wind Down Trust only with the consent of the Litigation Trustee or by order of the Bankruptcy Court. The act of transferring the Initial Litigation Trust Assets, as authorized by the Second Amended Plan, shall not be construed to destroy or limit any such assets or rights or be construed as a waiver of any right, and such rights may be asserted by the Litigation Trust as if the asset or right was still held by the relevant Debtor. In accordance with the Second Amended Plan, the Litigation Trust may abandon to creditors or otherwise not accept any Retained Causes of Action that the Litigation Trustee believes, in good faith, have no value to the Litigation Trust; *provided*, that the Litigation Trust Agreement shall provide for the assignment by creditors to the Litigation Trust of any such Retained Causes of Action so abandoned to creditors.

For the avoidance of doubt, the Litigation Trustee, on behalf of the Litigation Trust, shall step into the shoes of the Debtors as it relates to either communications that occurred prior to, or documents prepared before, April 20, 2022 with respect to Debtors' right to assert attorney-client privilege or any other privilege or immunity Debtor possesses, if any, and the Litigation Trustee shall be entitled to preserve, assert, access, or waive such privilege or immunity of the Debtors as it relates to such documents or communications. On the Effective Date, the Litigation Trustee shall have the power, right and responsibility to access or take possession of all books, files and records of the Debtors or Wind Down Debtors, as applicable, for purposes of carrying out the purpose of the Litigation Trust. At any time after the Effective Date, upon reasonable request of the Litigation Trustee, the Wind Down Trustee shall provide the Litigation Trustee with any of the Debtors' or the Wind Down Debtors' books, records, and files in the Wind Down Trust's or Wind Down Trustee's possession, custody, or control, and the Wind Down Trustee may, in good faith, provide such privileged information of the Debtors as is in the Wind Down Trustee's possession that relates to the evaluation and prosecution of the Retained Causes of Action; *provided*, that, notwithstanding the foregoing, the privilege of the Independent Directors, the DLP Independent Directors, and David F. Chavenson in his capacity as a former member of the Special Committee, in each case, is hereby recognized and shall remain in full force and effect and shall not be waived, nor shall any such privileged documents be turned over to any person or Entity without the consent of all Independent Directors or all DLP Independent Directors, as applicable. For the avoidance of doubt, neither the Independent Directors nor the DLP Independent Directors may waive Mr. Chavenson's personal privilege. The Wind Down Trustee shall use commercially reasonable efforts to assist the Litigation Trustee by providing additional information based on the books, files, and records in the Wind Down Trust's possession, provided that any such request for assistance is reasonable. Following the Effective Date, the Litigation Trust and the Litigation Trustee shall be deemed a party in interest with standing to appear in the Chapter 11 Cases and object to any pleadings Filed thereafter; *provided, however*, such standing and right to object does not alter the respective rights or responsibilities of the Litigation Trustee or the Wind Down Trustee under the Second Amended Plan, the Wind Down Trust Agreement, or the Litigation Trust Agreement, alter any governing

approval standard under applicable law, or otherwise limit the ability of any party with standing to respond to pleadings Filed, or objections raised, by the Litigation Trustee.

2. Litigation Trustee

The Litigation Trustee shall be an independent, third-party fiduciary selected by the Bondholder Committee and identified in the Plan Supplement, and shall be compensated at market rates; *provided*, that, for the avoidance of doubt, the Litigation Trustee shall have no affiliation with any Bondholder Committee member and must not own any Public L Bonds, New WDT Interests, or other Interests in or Securities issued by any of the Debtors. The Litigation Trustee shall have the sole authority to make decisions and take action with respect to the Initial Litigation Trust Assets, the Retained Causes of Action, and the Litigation Trust Reconciliation Claims, and shall have a duty to maximize the value of the assets of the Litigation Trust in accordance with the Litigation Trust Agreement. The Litigation Trustee shall confer with the Wind Down Trustee with respect to the commencement of any litigation in respect of such assets, provided that the ultimate decision with respect to whether to commence any litigation shall be in the sole discretion of the Litigation Trustee. For the avoidance of doubt, in exercising such sole discretion, the Litigation Trustee shall consider and may take such actions in connection with the exercise of such sole discretion that promote the greatest recovery to the holders of the New WDT Interests. The Litigation Trustee shall seek Bankruptcy Court approval, after notice and an opportunity for a hearing, of (a) any settlements with respect to the Retained Causes of Action, and (b) any other transaction with respect to any assets of the Litigation Trust, in each case, that has an economic value of \$5 million or more (in the Litigation Trustee's good faith determination) as of the date of such transaction.

The Litigation Trustee shall use the Initial Litigation Trust Funding Amount to fund all expenses related to its duties under the Second Amended Plan and the Litigation Trust Agreement. Thereafter, the Litigation Trust and the Litigation Trustee may use proceeds from monetizing the Retained Causes of Action to fund the reasonable and customary out-of-pocket expenses incurred by the Litigation Trust and Litigation Trustee. Beginning on the Effective Date, the Litigation Trustee shall have customary powers, including the power to employ (without further order of the Bankruptcy Court) professionals (including professionals previously engaged in the Chapter 11 Cases), employees, or other independent contractors to assist in carrying out its duties under the Second Amended Plan, including the Litigation Trust Agreement, and may compensate and reimburse the expenses of these professionals, employees, or other independent contractors based upon the nature of the work performed by such parties without further order of the Bankruptcy Court, subject to any limitations and procedures established by the Litigation Trust Agreement.

3. Reports to Be Filed by the Litigation Trust

Following the Effective Date, and unless otherwise ordered by the Bankruptcy Court, and during the existence of the Litigation Trust, the Litigation Trust shall File with the Bankruptcy Court (and provide to any other party entitled to receive any such report pursuant to the Litigation Trust Agreement), within 90 days after the end of each calendar year during the term of the Litigation Trust, and within 45 days after the end of each calendar quarter during the term of the Litigation Trust (other than the fourth quarter), a quarterly report regarding the administration of property subject to its ownership and control pursuant to the Second Amended Plan, receipts,

distributions made by it, an update regarding the status of the Retained Causes of Action being prosecuted by the Litigation Trust, and a summary of all major activities during the period.

4. Termination of the Litigation Trust

The initial term of the Litigation Trust shall be the lesser of: (a) three years; (b) the date all holders of New Series A1 WDT Interests and New Series A2 WDT Interests receive the full amount to which they are entitled to pursuant to the Second Amended Plan; and (c) the date that all Retained Causes of Action have been fully resolved, as reasonably determined by the Litigation Trustee in its sole determination; *provided, however*, that, subject to applicable law, the Litigation Trustee may extend the term of the Litigation Trust solely in the event termination would otherwise occur under subsection (a) of this paragraph by Filing a motion with the Bankruptcy Court prior to the expiration of the initial term and obtaining court approval of such extension, with a maximum extension of two (2) years per request (subject, in each instance, to reasonable consideration being given to implications of tax law and other applicable law of a proposed extension of the term of the Litigation Trust). The Wind Down Trustee and the Litigation Trustee will cooperate and confer to ensure that the Wind Down Trust does not terminate prior to the Litigation Trust. For the avoidance of doubt, no later than the termination of the Litigation Trust, the Litigation Trustee shall transfer all of the Litigation Trust's assets, including any remaining Retained Causes of Action and net proceeds realized therefrom, to the Wind Down Trust. Notwithstanding the foregoing, and for the avoidance of doubt, nothing in the Second Amended Plan (or the Plan Supplement, as applicable) shall prohibit the Litigation Trustee from making interim transfers of Cash realized by the Litigation Trust to the Wind Down Trust for distribution to holders of New WDT Interests in accordance with the Second Amended Plan.

C. Priority of Cash Distributions to Holders of New WDT Interests

The Wind Down Trustee shall make an initial Cash distribution to holders of New WDT Interests consisting of the Net Cash Proceeds, if any, within 60 days after the Effective Date, and on a semi-annual basis thereafter to the extent of any Net Cash Proceeds; *provided*, that the Wind Down Trustee may, in its sole discretion, make additional special distributions to the extent of any Net Cash Proceeds available; *provided, further*, that, in each instance, no distribution shall be required unless the Net Cash Proceeds then held by the Wind Down Trustee is equal to or greater than the Minimum Distribution Amount of \$15,000,000 in Cash.

1. Distributions From the Monetization of Wind Down Trust Assets

Any Cash distributions, including any distributions consisting of the Net Cash Proceeds realized from the monetization of the Wind Down Trust Assets, including the interests in Beneficial or FOXO, made by the Wind Down Trust to holders of New WDT Interests, after establishment of appropriate reserves for payment of Wind Down Trust expenses to the extent provided in the Wind Down Budget or the Wind Down Trust Agreement (or approved by separate order of the Bankruptcy Court), shall be distributed in the following order of priority (with no distributions to any junior class until all payments are made to senior classes in full):

1. the New Series A1 WDT Interests (if any) issued to the Indenture Trustee in connection with the Indenture Fee and Expense Claims in Class 3, up to the outstanding amount of such Claims;
2. all other New Series A1 WDT Interests, up to the Allowed outstanding prepetition amount of Allowed Bondholder Claims in Class 3;
3. the New Series A2 WDT Interests, up to the Allowed outstanding prepetition amount of Allowed LBM Subordinated Claims in Class 3;
4. the New Series A1 WDT Interests and the New Series A2 WDT Interests, up to the amount of interest accrued on such New Series A1 WDT Interests and New Series A2 WDT Interests, which interest shall accrue under the New WDT Documents from April 20, 2022 calculated at a 9% per annum interest rate;
5. the New Series B WDT Interests, up to the Allowed prepetition outstanding amount of Class 4(a) Allowed General Unsecured Claims;
6. the New Series B WDT Interests, up to the Allowed postpetition balance of Class 4(a) Allowed General Unsecured Claims, comprised of interest on the Allowed prepetition amount of such Claims starting from April 20, 2022 calculated at the Federal Judgment Rate;
7. the New Series C WDT Interests and the New Series D WDT Interests, on a pro rata *pari passu* basis, per liquidation rights under the New WDT Documents and applicable law, up to the Allowed aggregate outstanding amount of the Class 8 Series 1 Preferred Interests and Class 9 Series 2 Preferred Interests (based on each Series 1 Preferred Interest and each Series 2 Preferred Interest having an initial stated value of \$1,000.00 per share); and
8. the New Series E WDT Interests.

2. Distributions of Net Proceeds Realized by the Litigation Trust

Distributions of net proceeds realized by the Litigation Trust shall be made by the Wind Down Trustee, or by the Litigation Trustee at the direction of the Wind Down Trustee, in the following order of priority (with no distributions to junior classes until each senior class is paid in full):

1. to holders of New Series A1 WDT Interests (subject to prior payment in full of Indenture Fee and Expense Claims) on account of the Indenture Diminution Claims, up to the Allowed amount of such Claims;
2. on a *pari passu* pro rata basis (a) holders of the New Series A1 WDT Interests and the New Series A2 WDT Interests (subject to the prior payment in full of the Indenture Fee and Expense Claims and recognizing the intercreditor arrangements described in Article IV.H.1 through H.4 of the Second Amended Plan vis-à-vis the New Series A1 WDT Interests and the New Series A2 WDT Interests), on the one hand, and (b) holders of New Series B WDT Interests on the other hand, up to the aggregate outstanding prepetition amounts of Allowed Bondholder

Claims and Allowed LBM Subordinated Claims in Class 3, and Allowed Class 4(a) General Unsecured Claims, calculated in accordance with Article IV.H of the Second Amended Plan;

3. on a *pari passu* pro rata basis (a) holders of the New Series A1 WDT Interests and the New Series A2 WDT Interests (subject to recognizing the intercreditor arrangements described in Article IV.H.1 through H.4 of the Second Amended Plan vis-à-vis the New Series A1 WDT Interests and the New Series A2 WDT Interests), on the one hand, and (b) holders of New Series B WDT Interests on the other hand, up to the amount of interest accrued on such New Series A1 WDT Interests and New Series A2 WDT Interests as set forth in the New WDT Documents, and Allowed Class 4(a) General Unsecured Claims, calculated in accordance with Article IV.H of the Second Amended Plan;

4. holders of New Series C WDT Interests and New Series D WDT Interests on a *pari passu* pro rata basis, per liquidation rights under the New WDT Documents and applicable law, up to the outstanding Allowed aggregate amount of the Class 8 Series 1 Preferred Interests and Class 9 Series 2 Preferred Interests (based on each Series 1 Preferred Interest and each Series 2 Preferred Interest having an initial stated value of \$1,000.00 per share); and

5. holders of the New Series E WDT Interests.

D. Exemption from Registration Requirements

The Debtors intend that the Wind Down Trust will be organized in compliance with applicable law such that the New WDT Interests will not be deemed to be or treated as securities under applicable law. As a result, the Debtors do not believe that registration under the Securities Act and applicable state law in connection with the issuance and distribution of the New WDT Interests or an exemption from such registration requirements is required. However, to the extent that the New WDT Interests issued under the Second Amended Plan are deemed securities, the issuance and distribution thereof would qualify for issuance without registration under the Securities Act or any similar federal, state, or local law pursuant to section 1145 of the Bankruptcy Code. To the extent that the issuance and distribution of the New WDT Interests issued under the Second Amended Plan is completed pursuant to section 1145 of the Bankruptcy Code, such New WDT Interests would be exempt from, among other things, the registration requirements of Section 5 of the Securities Act and any other applicable U.S. state or local law requiring registration prior to the offering, issuance, distribution, or sale of securities. Pursuant to section 1145 of the Bankruptcy Code, any such New WDT Interests issued under the Second Amended Plan: (1) would not be “restricted securities” as defined in Rule 144(a)(3) under the Securities Act; and (2) as a matter of federal securities law, would be freely tradable and transferrable under the federal securities laws by any holder thereof that (a) is not an “affiliate” of the Wind Down Trust, as defined in Rule 144(a)(1) under the Securities Act, (b) has not been such an “affiliate” within three months of such transfer, (c) has not acquired the New WDT Interests from an “affiliate” within one year of such transfer, and (d) is not an Entity that is an “underwriter” as defined in section 1145(b) of the Bankruptcy Code.

In accordance with the Second Amended Plan, the New WDT Documents will provide that the New WDT Interests may not be transferred, sold, pledged or otherwise disposed of, or offered for sale, except for transfers by will, intestacy or operation of law. The Wind Down Trust will be

organized in compliance with applicable law such that the New WDT Interests will not be treated as securities and under such facts the Debtors do not believe that registration under the Securities Act and applicable state law in connection with the issuance and distribution of the New WDT Interests or an exemption from such registration requirements would be required. The Wind Down Trustee will be permitted to determine in its sole discretion to take such actions that are necessary or reasonably advisable (including, without limitation, completing a registration under the Securities Exchange Act) to modify or remove any contractual restrictions on transferability of the New WDT Interests, with any such determination by the Wind Down Trustee, and all costs associated therewith, to be deemed a determination with respect to the monetization of the Wind Down Trust Assets subject to Bankruptcy Court approval to the extent provided pursuant to Article IV.A.3 of the Second Amended Plan and to be evaluated solely under a reasonable business judgment standard.

E. Releases, Exculpation and Injunction

1. Release of Liens

The Second Amended Plan contains the following provision regarding release of liens:

Except as otherwise provided in the Second Amended Plan or in any contract, instrument, release, or other agreement or document created pursuant to or in connection with the Second Amended Plan, the Confirmation Order, or any contract, instrument, release, or other agreement or document created pursuant to the Second Amended Plan, on the Effective Date and concurrently with the applicable distributions made pursuant to the Second Amended Plan and, in the case of a Secured Claim, satisfaction in full of the portion of the Secured Claim that is Allowed as of the Effective Date, all mortgages, deeds of trust, Liens, pledges, or other security interests against any property of the Estates shall be fully released and discharged, and all of the right, title, and interest of any Holder of such mortgages, deeds of trust, Liens, pledges, or other security interests shall revert to the Debtors and their successors and assigns (including the Wind Down Debtors, Wind Down Trust, and/or the Litigation Trust, as applicable). Any Holder of such Secured Claim (and the applicable agents for such Holder) shall be authorized and directed, at the sole cost and expense of the Wind Down Trust, to release any collateral or other property of any Debtor or their successors and assigns (including the Wind Down Debtors, Wind Down Trust, and/or the Litigation Trust, as applicable), including any cash collateral and possessory collateral, held by such Holder (and the applicable agents for such Holder), and to take such actions as may be reasonably requested by the Wind Down Trust to evidence the release of such Lien, including the execution, delivery, and filing or recording of such releases. The presentation or filing of the Confirmation Order to or with any federal, state, provincial, or local agency or department shall constitute good and sufficient evidence of, but shall not be required to effect, the termination of such Liens.

2. Release by the Debtors

The Second Amended Plan contains the following provision regarding releases by the Debtors:

Pursuant to section 1123(b) of the Bankruptcy Code, in exchange for good and valuable consideration, the adequacy of which is hereby confirmed, on and after the Effective Date, each Released Party (but no Non-Released Party) is, and is deemed hereby to be, fully, conclusively, absolutely, unconditionally, irrevocably, and forever released and discharged by the Debtors, the Wind Down Debtors, and their Estates, and any person seeking to exercise the rights of the Debtors or their Estates, including any successors to the Debtors or any Estates representatives appointed or selected pursuant to section 1123(b)(3) of the Bankruptcy Code, in each case on behalf of themselves and their respective successors, assigns, and representatives, and any and all other Entities who may purport to assert any Cause of Action, directly or derivatively, by, through or for the Debtors or their Estates, from any and all Claims and Causes of Action, whether known or unknown, including any derivative claims, asserted or assertable on behalf of the Debtors, whether known or unknown, foreseen or unforeseen, matured or unmatured, existing or hereafter arising, contingent or non-contingent, in law, equity, contract, tort or otherwise, except for any claims related to any act or omission that is determined in a Final Order to have constituted actual fraud, willful misconduct, intentional breach of fiduciary duty, or gross negligence, that the Debtors, the Wind Down Debtors, or their Estates, including any successors to the Debtors or any Estates representative appointed or selected pursuant to section 1123(b) of the Bankruptcy Code, would have been legally entitled to assert in their own right (whether individually or collectively) or on behalf of the Holder of any Claim or Interest in, a Debtor or other Entity, or that any Holder of any Claim against, or Interest in, a Debtor or other Entity could have asserted on behalf of the Debtors, based on or relating to, or in any manner arising from, in whole or in part, the Debtors (including the capital structure management, ownership or operation thereof), the business or contractual arrangement between the Debtors and any Released Party, any Securities issued by the Debtors and the ownership thereof, the assertion or enforcement of rights and remedies against the Debtors, the Debtors' in- or out-of-court restructuring efforts, any Avoidance Actions (but excluding Avoidance Actions brought as counterclaims or defenses to Claims asserted against the Debtors), intercompany transactions between or among a Debtor and another Debtor, the formulation, preparation, dissemination, negotiation, or Filing of the Disclosure Statement, the Second Amended Plan (including, for the avoidance of doubt, the Plan Supplement), the Vida DIP Financing Facility, the Vida Exit Financing Facility, or any Wind Down Transaction, contract, instrument, release, or other agreement or document (including any legal opinion requested by any Entity regarding any transaction, contract, instrument, document or other agreement contemplated by the Second Amended Plan or the reliance by any Released Party on the Second Amended Plan or the Confirmation Order in lieu of such legal opinion) created or entered into in connection with the Disclosure Statement, the Vida Exit Financing Facility Documents, the Second Amended Plan, or the Plan Supplement, before or during the Chapter 11 Cases, the Chapter 11 Cases, the filing of the Chapter 11 Cases, the pursuit of Confirmation, the administration and implementation of the Second Amended Plan, including the issuance or distribution of Securities pursuant to the Second Amended Plan, or the distribution of property under the Second Amended Plan, or upon any related act or omission, transaction, agreement, event, or other occurrence related or relating to any of the foregoing taking place on or before the Effective Date related or relating to the foregoing including all relief obtained by the Debtors in the Chapter 11 Cases. For the avoidance of doubt, the LBM Released Parties, to the extent that LBM has not withdrawn

from the settlement described in Article IV.I of the Second Amended Plan, shall constitute Released Parties with respect to this Debtor Release.

Notwithstanding anything to the contrary in the foregoing, the releases set forth above do not release: (1) post-Effective Date obligations of any party or Entity under the Second Amended Plan, the Confirmation Order, any Wind Down Transaction, or any other document, instrument, or agreement (including those set forth in the Plan Supplement) executed to implement the Second Amended Plan, including the Vida Exit Financing Facility Documents, or any Claim or obligation arising under the Second Amended Plan; (2) the rights of any Holder of Allowed Claims to receive distributions under the Second Amended Plan; (3) the Retained Causes of Action; (4) any claims related to any act or omission that is determined in a Final Order to have constituted actual fraud, willful misconduct, intentional breach of fiduciary duty, or gross negligence; (5) the Debtors' prepetition legal counsel solely with respect to claims or causes of action arising from such counsel's prepetition advice to the Debtors and/or any former directors or officers of the Debtors other than advice directly relating to the preparation and filing of the Chapter 11 Cases (it being understood any prepetition advice to the Debtors relating to prepetition transactions between the Debtors and Beneficient shall not constitute advice directly relating to the preparation and filing of the Chapter 11 Cases); or (6) any Non-Released Party.

Entry of the Confirmation Order shall constitute the Bankruptcy Court's approval, pursuant to Bankruptcy Rule 9019, of the foregoing Debtor Release, which includes by reference each of the related provisions and definitions contained in the Second Amended Plan, and further, shall constitute the Bankruptcy Court's finding that the Debtor Release is: (a) in exchange for the good and valuable consideration provided by the Released Parties, including, without limitation, the Released Parties' contributions to facilitating the Wind Down Transactions and implementing the Second Amended Plan; (b) a good faith settlement and compromise of the Claims released by the Debtor Release; (c) in the best interests of the Debtors and all holders of Claims and Interests; (d) fair, equitable, and reasonable; (e) given and made after due notice and opportunity for hearing; and (f) a bar to any of the Debtors, the Wind Down Debtors, or the Debtors' Estates asserting any Claim or Cause of Action released pursuant to the Debtor Release.

3. [RESERVED]

The Second Amended Plan does not contain third party releases other than to the extent provided in Article VIII.C (Releases by the Debtors) or Article VIII.E (Exculpation).

4. Exculpation

The Second Amended Plan contains the following provision regarding exculpation:

Except as otherwise expressly stated in the Second Amended Plan or the Confirmation Order, as of the Effective Date, each Exculpated Party shall be deemed to be released and exculpated from any claim, obligation, Cause of Action, or liability for any Exculpated Claim, except for claims related to any act or omission that is determined in a Final Order to have constituted intentional breach of fiduciary duty, actual fraud, willful

misconduct, or gross negligence, but in all respects each Debtor and each Exculpated Party shall be entitled to reasonably rely upon the advice of counsel with respect to their duties and responsibilities pursuant to the Second Amended Plan. The Exculpated Parties have, and upon the Consummation of the Second Amended Plan, shall be deemed to have, participated in good faith and in compliance with applicable law with regard to the restructuring of Claims and Interests in the Chapter 11 Cases and in connection with the Wind Down Transactions, the negotiation, formulation, or preparation of the Wind Down Documents or related agreements, instruments, or other documents (including, for the avoidance of doubt, providing any legal opinion requested by any Entity regarding any transaction, contract, instrument, document, or other agreement contemplated by the Second Amended Plan or the reliance by any Released Party on the Second Amended Plan or the Confirmation Order in lieu of such legal opinion) in connection with the Second Amended Plan, and the solicitation of the Second Amended Plan and distributions pursuant to the Second Amended Plan and, therefore, are not, and on account of such distributions shall not be, liable at any time for the violation of any applicable law, rule, or regulation governing the solicitation of acceptances or rejections of the Second Amended Plan or such distributions made pursuant to the Second Amended Plan, except for claims related to any act or omission that is determined in a Final Order to have constituted intentional breach of fiduciary duty, actual fraud, willful misconduct, or gross negligence. The Debtors and the Creditor Proponents agree that (1) neither the act itself of Filing or prosecuting a motion to approve a settlement of any Estate Causes of Action with Beneficient, any of its Affiliates or related parties, and/or any other Non-Released Party nor the act itself of Filing or prosecuting any objection to any such settlement in and of itself constitutes an intentional breach of fiduciary duty, and (2) any claims that the Debtors or the Creditor Proponents may seek to bring against any Exculpated Party shall be limited to any actions of such Exculpated Party solely after the date of execution of the Mediation Agreement; *provided* that any such claims must be Filed exclusively in the Bankruptcy Court and in accordance with the Federal Rules of Civil Procedures, and such claims shall be pled with specificity with respect to the who, what, when, where, and how of the alleged wrongful conduct.

5. Injunction

The Second Amended Plan contains the following provision regarding injunction:

Except as otherwise expressly provided in the Second Amended Plan or the Confirmation Order or for obligations or distributions required to be paid pursuant to the Second Amended Plan or the Confirmation Order, all Entities who have held, hold, or may hold claims that have been released pursuant to Article VIII of the Second Amended Plan are permanently enjoined, from and after the Effective Date, from taking any of the following actions against, as applicable, the Debtors, the Released Parties, or the Exculpated Parties: (1) commencing or continuing in any manner any action or other proceeding of any kind on account of or in connection with or with respect to any of the claims or interests released hereunder; (2) enforcing, attaching, collecting, or recovering by any manner or means any judgment, award, decree, or order against such Entities on account or in connection with or with respect to any claims or interests released hereunder; (3) creating, perfecting, or enforcing any Lien or encumbrance of any kind against such Entities or the property of such Entities on account or in connection with or with respect to any claims or

interests released hereunder; (4) asserting any right of setoff, subrogation, or recoupment of any kind against any obligation due from such Entities or against the property or the Estates of such Entities on account or in connection with or with respect to any claims or interests released hereunder, unless such holder has Filed a motion requesting the right to perform such setoff on or before the Effective Date, and notwithstanding an indication of a Claim or Interest or otherwise that such Holder asserts, has, or intends to preserve any right of setoff pursuant to applicable law or otherwise; and (5) commencing or continuing in any manner any action or other proceeding of any kind on account of or in connection with or with respect to any claims or interests released or settled pursuant to the Second Amended Plan.

Upon entry of the Confirmation Order, all Holders of Claims and Interests and their respective current and former employees, agents, officers, directors, principals, and direct and indirect Affiliates shall be enjoined from taking any actions to interfere with the implementation or Consummation of the Second Amended Plan. Except as otherwise set forth in the Confirmation Order, each Holder of an Allowed Claim or Allowed Interest, as applicable, by accepting, or being eligible to accept, distributions under the Second Amended Plan shall be deemed to have consented to the injunction provisions set forth in the Second Amended Plan.

F. Conditions Precedent to the Effective Date

It shall be a condition to Consummation that the following conditions shall have been satisfied or waived pursuant to the provisions of Article IX.C of the Second Amended Plan:

- (a) the Bankruptcy Court shall have entered the Confirmation Order, subject to the Proponents' Consent Right, and such order shall have become a Final Order that has not been stayed, modified, or vacated on appeal, subject to the Debtors' right to waive any appeal period (with the reasonable consent of the Creditor Proponents);
- (b) the Debtors shall have assumed the D&O Liability Insurance Policies, which shall include, for the avoidance of doubt, policies that provide coverage for periods and were purchased prior to April 20, 2022;
- (c) the Debtors shall have obtained additional director and officer liability tail insurance coverage for the period from April 20, 2022 to the Effective Date, which insurance coverage must not terminate or otherwise reduce the coverage set forth in the existing D&O Liability Insurance Policies, the form and substance of which being subject to the Proponents' Consent Right;
- (d) the Vida Exit Financing Facility Documents shall have been executed, delivered, be in full force and effect (with all conditions precedent thereto having been satisfied or waived), and any amendments, modifications or supplements to the Vida Exit Financing Facility Documents that were Filed at Docket No. 975 shall be in form and substance subject to the Proponents' Consent Right;
- (e) the Investigations Committee shall have completed its independent investigation with respect to any releases granted pursuant to the Second Amended Plan;

- (f) the Wind Down Trust Agreement shall have been executed and shall be in form and substance subject to the Proponents' Consent Right;
- (g) the Wind Down Budget shall have been delivered to the Creditor Proponents and shall be in form and substance subject to the Proponents' Consent Right;
- (h) the Wind Down Trust Assets shall have been transferred to the Wind Down Trust;
- (i) the Wind Down Trustee shall have accepted the appointment;
- (j) the Litigation Trust Agreement shall have been executed and shall be in form and substance subject to the Proponents' Consent Right;
- (k) the Litigation Trustee shall have been appointed and have accepted the appointment;
- (l) the Initial Litigation Trust Assets shall have been transferred to the Litigation Trust;
- (m) the New WDT Interests shall have been issued;
- (n) the New WDT Documents shall be in form and substance subject to the Proponents' Consent Right;
- (o) any Plan Supplement documents, including any exhibits, schedules, amendments, modifications, or supplements thereto, not otherwise identified in Article IX.A of the Second Amended Plan, shall have been Filed and shall be in form and substance subject to the Proponents' Consent Right;
- (p) all governmental and material third party approvals and consents, including Bankruptcy Court approval, necessary in connection with the transactions contemplated by the Second Amended Plan shall have been obtained, not be subject to unfulfilled conditions and be in full force and effect, and all applicable waiting periods shall have expired without any action being taken or threatened by any competent authority that would restrain, prevent, or otherwise impose materially adverse conditions on such transactions; *provided*, it being understood that any 1940 Act matters in connection with the Wind Down Trust shall be addressed as set forth in Article IV.A of the Second Amended Plan;
- (q) the Professional Fee Escrow Account shall have been funded with Cash in the amount of the aggregate Professional Fee Escrow Amount for all Professionals;
- (r) to the extent of Cash distributions would apply to any such Disputed Claims, and to the extent that Cash is available, the Disputed Claims Reserve shall have been established and funded; and
- (s) any other corporate or related actions necessary or advisable in the reasonable business judgment of the Debtors and subject to the Proponents' Consent Right for the Second Amended Plan to become effective shall have been taken.

VIII. RISK FACTORS

Holders of Claims and Interests should read and consider carefully the risk factors set forth below before voting to accept or reject the Second Amended Plan. Although there are many risk factors discussed below, these factors should not be regarded as constituting the only risks present in connection with the Debtors' business or the Second Amended Plan or its implementation. Holders of Claims and Interests should also refer to the "Risk Factors" sections of the reports filed by GWGH with the SEC.

THE DEBTORS HAVE PROVIDED THE FOLLOWING RISK FACTOR DESCRIPTIONS TO SATISFY THE DISCLOSURE REQUIREMENTS OF SECTION 1125 OF THE BANKRUPTCY CODE. DISCLOSURE AND DISCUSSION OF ADDITIONAL RISK FACTORS RELATED TO THE DEBTORS' BUSINESS MAY BE FOUND IN PUBLICLY AVAILABLE SECURITIES FILINGS.⁶¹

A. Bankruptcy Law Considerations

The occurrence or non-occurrence of any or all of the following contingencies, and any others, could affect distributions available to Holders of Allowed Claims and Interests under the Second Amended Plan but will not necessarily affect the validity of the vote of the Impaired Class to accept or reject the Second Amended Plan or necessarily require a re-solicitation of the votes of Holders of Claims and Interests in such Impaired Class.

1. Parties in Interest May Object to the Second Amended Plan's Classification of Claims and Interests.

Section 1122 of the Bankruptcy Code provides that a plan may place a claim or an equity interest in a particular class only if such claim or equity interest is substantially similar to the other claims or equity interests in such class. The Debtors believe that the classification of the Claims and Interests under the Second Amended Plan complies with the requirements set forth in the Bankruptcy Code because the Debtors created Classes of Claims and Interests each encompassing Claims or Interests, as applicable, that are substantially similar to the other Claims or Interests, as applicable, in each such Class. Nevertheless, there can be no assurance that the Bankruptcy Court will reach the same conclusion.

2. The Debtors May Fail to Receive Sufficient Votes in Favor of the Second Amended Plan.

If votes are received in number and amount sufficient to enable the Bankruptcy Court to confirm the Second Amended Plan, the Debtors intend to seek, as promptly as practicable thereafter, Confirmation of the Second Amended Plan. Section 1126(c) of the Bankruptcy Code defines acceptance of a plan by a class of impaired claims as acceptance by holders of at least two-thirds in dollar amount and more than one-half in a number of allowed claims in that class, counting only those claims that have *actually* voted to accept or to reject the plan. In the event that sufficient

⁶¹ GWGH's most recent 10-K was filed on November 5, 2021 with respect to the year ending December 31, 2020. This 10-K and additional filings can be found at the following webpage: <https://www.sec.gov/edgar/browse/?CIK=0001522690>.

votes are not received, the Debtors may seek to confirm an alternative chapter 11 plan or transaction. There can be no assurance that the terms of any such alternative chapter 11 plan or other transaction would be similar or as favorable to the Holders of Allowed Claims and Interests as those proposed in the Second Amended Plan and the Debtors do not believe that any such transaction exists or is likely to exist that would be more beneficial to the Debtors' Estates than the Second Amended Plan.

3. The Debtors May Not Be Able to Secure Confirmation of the Second Amended Plan.

Section 1129 of the Bankruptcy Code sets forth the requirements for confirmation of a chapter 11 plan, and requires, among other things, a finding by the Bankruptcy Court that: (a) such plan "does not unfairly discriminate" and is "fair and equitable" with respect to any non-accepting classes; (b) confirmation of such plan is not likely to be followed by a liquidation or a need for further financial reorganization unless such liquidation or reorganization is contemplated by the plan; and (c) the value of distributions to non-accepting holders of claims or equity interests within a particular class under such plan will not be less than the value of distributions such holders would receive if the debtors were liquidated under chapter 7 of the Bankruptcy Code.

Even if the requisite votes in favor of the Second Amended Plan are received, there can be no assurance that the Bankruptcy Court will confirm the Second Amended Plan. A non-accepting Holder of an Allowed Claim might challenge either the adequacy of this Disclosure Statement or whether the balloting procedures and voting results satisfy the requirements of the Bankruptcy Code or Bankruptcy Rules. Even if the Bankruptcy Court determines that this Disclosure Statement, the balloting procedures, and voting results are appropriate, the Bankruptcy Court may still decline to confirm the Second Amended Plan if it finds that any of the statutory requirements for Confirmation are not met. If the Second Amended Plan is not confirmed by the Bankruptcy Court, it is unclear what, if anything, Holders of Allowed Claims and Interests would ultimately receive.

The Debtors reserve the right to modify the terms and conditions of the Second Amended Plan as necessary for Confirmation. Any such modifications could result in less favorable treatment of any non-accepting class of Claims or Interests, as well as any class junior to such non-accepting class, than the treatment currently provided in the Second Amended Plan. Such a less favorable treatment could include a distribution of property with a lesser value than currently provided in the Second Amended Plan or no distribution whatsoever under the Second Amended Plan.

4. Nonconsensual Confirmation.

In the event that any impaired class of claims or interests does not accept a chapter 11 plan, a bankruptcy court may nevertheless confirm a plan at the proponents' request if at least one impaired class (as defined under section 1124 of the Bankruptcy Code) has accepted the plan (with such acceptance being determined without including the vote of any "insider" in such class), and, as to each impaired class that has not accepted the plan, the bankruptcy court determines that the plan "does not discriminate unfairly" and is "fair and equitable" with respect to the dissenting impaired class(es). The Debtors may request such nonconsensual Confirmation in accordance with

subsection 1129(b) of the Bankruptcy Code. Nevertheless, there can be no assurance that the Bankruptcy Court will reach the conclusion that the Second Amended Plan meets the requirements for nonconsensual Confirmation. In addition, the pursuit of nonconsensual Confirmation or Consummation of the Second Amended Plan may result in, among other things, increased expenses relating to professional compensation.

5. The Debtors' Exclusivity Period May Expire.

At the outset of the Chapter 11 Cases, the Bankruptcy Code provides the Debtors with the exclusive right to propose the Second Amended Plan and prohibits creditors and others from proposing a plan. The Debtors have retained the exclusive right to propose the Second Amended Plan and solicit votes with respect to the Second Amended Plan as of the date hereof. If the Bankruptcy Court terminates that right, however, or the exclusivity period with respect to plan solicitation expires, there could be a material adverse effect on the Debtors' ability to achieve confirmation of the Second Amended Plan in order to achieve the Debtors' stated goals.

6. Risk of Nonoccurrence of the Effective Date.

As more fully set forth in Article IX of the Second Amended Plan, the Effective Date of the Second Amended Plan is subject to a number of conditions precedent. If such conditions precedent are not waived or not met, the Effective Date will not occur and the Second Amended Plan will not be consummated. Although the Debtors believe that the Effective Date may occur quickly after the Confirmation Date, there can be no assurance as to such timing or as to whether the Effective Date will, in fact, occur.

7. The Chapter 11 Cases May be Converted to Cases under Chapter 7 of the Bankruptcy Code.

If the Bankruptcy Court finds that it would be in the best interest of creditors and/or the debtor in a chapter 11 case, the Bankruptcy Court may convert a chapter 11 bankruptcy case to a case under chapter 7 of the Bankruptcy Code. In such event, a chapter 7 trustee would be appointed or elected to liquidate the debtor's assets for distribution in accordance with the priorities established by the Bankruptcy Code. The Debtors believe that liquidation under chapter 7 would result in significantly smaller distributions being made to Holders of Allowed Claims and Interests than those provided for in the Second Amended Plan because of (a) the likelihood that the assets would have to be sold or otherwise disposed of in a disorderly fashion over a short period of time, (b) additional administrative expenses involved in the appointment of a chapter 7 trustee, and (c) additional expenses and Claims, some of which would be entitled to priority, that would be generated during the liquidation, including Claims resulting from the rejection of Unexpired Leases and other Executory Contracts in connection with cessation of operations.

8. The Debtors May Object to the Amount or Classification of a Claim.

Except as otherwise provided in the Second Amended Plan, the Debtors reserve the right to object to the amount or classification of any Claim under the Second Amended Plan. The estimates set forth in this Disclosure Statement cannot be relied upon by any Holder of a Claim where such Claim is subject to, or may become subject to, an objection. Any Holder of a Claim

that is subject to, or becomes subject to, an objection may not receive its expected share of the estimated distributions described in this Disclosure Statement.

9. Contingencies Could Affect Votes of Impaired Classes to Accept or Reject the Second Amended Plan.

The distributions available to Holders of Allowed Claims and Interests under the Second Amended Plan can be affected by a variety of contingencies, including, without limitation, whether the Bankruptcy Court orders certain Allowed Claims or Interests to be subordinated to other Allowed Claims and Interests. The occurrence of any and all such contingencies, which could affect distributions available to Holders of Allowed Claims and Interests under the Second Amended Plan, will not affect the validity of the vote taken by the Impaired Class to accept or reject the Second Amended Plan or require any sort of revote by the Impaired Class.

The estimated Allowed Claims and Interests and associated recoveries set forth in this Disclosure Statement are based on various assumptions, and the actual Allowed amounts of Claims and Interests may significantly differ from the estimates. Should one or more of the underlying assumptions ultimately prove to be incorrect, the actual Allowed amounts of Claims and Interests may vary from the estimated Claims and Interests contained in this Disclosure Statement. Moreover, the Debtors cannot determine with any certainty at this time, the number or amount of Claims or Interests that will ultimately be Allowed. Such differences may materially and adversely affect, among other things, the percentage recoveries to Holders of Allowed Claims and Interests under the Second Amended Plan.

10. The Second Amended Plan's Release, Injunction, and Exculpation Provisions May Not Be Approved.

Article VIII of the Second Amended Plan provides for certain releases, injunctions, and exculpations. The Debtors believe that the releases, injunctions, and exculpations set forth in the Second Amended Plan comply with the requirements for approval of such provisions under applicable law. Nevertheless, there can be no assurance that the Bankruptcy Court will reach the same conclusion.

11. The Total Amount of Allowed Administrative and Priority Claims May Exceed the Amount of Distributable Cash and/or Be Higher Than Anticipated.

The amount of cash the Debtors ultimately receive from the Vida Exit Financing Facility and from other sources prior to and following the Effective Date may not be sufficient to pay Allowed Administrative Claims or Allowed Priority Claims, which claims must be paid in full in cash on the Effective Date pursuant to Section 1129(a)(9) of the Bankruptcy Code. Additionally, Allowed Administrative Claims or Allowed Priority Claims may be higher than anticipated. Accordingly, there is a risk that the Debtors will not be able to consummate a chapter 11 plan. If the Debtors are unable to consummate the Second Amended Plan on a timely basis, the Debtors could become administratively insolvent

12. Certain Tax Implications of the Second Amended Plan.

Holders of Allowed Claims should carefully review Article XII of this Disclosure Statement, entitled “CERTAIN UNITED STATES FEDERAL INCOME TAX CONSEQUENCES OF THE SECOND AMENDED PLAN,” to determine how the tax implications of the Second Amended Plan and the Chapter 11 Cases may adversely affect the Debtors, and certain Holders of Claims and Interests.

B. Risks Related to Recoveries under the Second Amended Plan and to the Wind Down Trust and Wind Down Trust Assets

1. Beneficient May Be Unable to Operate Its Business Successfully, Which Would Negatively Impact the Value of the Wind Down Trust’s Interests in Beneficient.

The Wind Down Trust’s ability to realize significant value for its interests in Beneficient will depend on Beneficient’s ability to operate its business successfully. Beneficient does not have significant operating history. A description of the risks regarding Beneficient’s business plan is included under the heading “Risk Factors – Risks Related to Our Liquidity Products” in GWGH’s Annual Report on Form 10-K filed with the SEC on November 5, 2021 and is incorporated herein by reference. The Ben S-4 that was filed with the SEC in connection with the Avalon Business Combination includes additional and updated risks related to Beneficient, including risks related to Beneficient’s organizational structure, limited operating history, relationship with the Debtors, litigation, liquidity products business, broker-dealer business, technology and third parties, intellectual property, proposed insurance business, accounting policies, growth strategy, economic environment and capital markets, regulatory and legal issues, etc.

One potential litigation risk is that Beneficient is unable to resolve potential claims and causes of action that the Debtors (and following the Effective Date, the Litigation Trust) have available against it. As discussed in Article II.B.3, the Debtors (through the Investigations Committee) are in discussions with Beneficient and the Beneficient Parties regarding a potential resolution of the Debtors’ available claims and causes of action against such parties, but no such resolution has been reached as of the date of this Disclosure Statement. Beneficient contends that if such potential claims and causes of action are not released or resolved through mediation or otherwise, any attendant litigation, depending on its outcome, or the potential for such litigation, could have a material adverse effect on Beneficient’s operations, financial condition, or ability to close the Avalon Business Combination, and could result in a decline of the perceived value of the post-transaction company, which could ultimately be reflected as a reduction in the market price of the securities to be held in New Beneficient.⁶² A discussion of this and some additional risks related to Beneficient can be found in Article II.A.3 of this Disclosure Statement.

Holders of Claims and Interests are urged to read the “Risk Factors” sections of the Ben S-4. If the Avalon Business Combination is consummated and stock of the combined company is listed on Nasdaq, the trading price of the Wind Down Trust’s interests in New Beneficient may go

⁶² The Bondholder Committee believes that the pursuit of such potential claims and causes of action may provide for greater value to the Debtors’ Estates than the equity interests the Debtors currently hold in Beneficient and are proposed to hold in Beneficient upon completion of the Avalon Business Combination.

up or down based on the performance of New Beneficient and other factors. As a result, there can be no assurance that the Wind Down Trust will realize a significant, or any, return on its interests in Beneficient.

2. The Business Combination of Beneficient and Avalon May Not be Consummated.

The Avalon Business Combination is subject to various closing conditions, including receipt of regulatory approvals, approval of Avalon's stockholders, the registration of the securities to be issued in connection with the Avalon transaction under the Securities Act, the listing of such securities on the Nasdaq stock market, and the accuracy of the parties' representations and warranties in the business combination agreement and compliance with the covenants set forth therein. There is no assurance that the Avalon Business Combination will occur on a timely basis or at all.

Ben LP has filed the Ben S-4 in connection with the proposed Avalon Business Combination, and that document contains risk factors that address the risks associated with the closing of the transaction and the risks associated with the post-transaction business of Beneficient. Holders are advised to review the risk factors in the Ben S-4, including any amendments thereto. Under the terms of the documents governing the Company's interest in BCH, such interests in BCH that would be transferred to the Wind Down Trust as part of the Second Amended Plan will be converted into more structurally subordinated common equity interests of the combined company, which may reduce their value. In addition, the federal securities laws may create limitations on the ability of the Wind Down Trust to sell its stock in New Beneficient following completion of the Avalon Business Combination, which would limit the ability of the Wind Down Trustee to dispose of such shares in New Beneficient.

As discussed in Article IV.A.2.d of this Disclosure Statement, Avalon has obtained the Extension extending of the period of time it has to consummate its initial business combination by three months from January 8, 2023 to July 8, 2023. Any further extensions will require Avalon's stockholders to approve an amendment to its certificate of incorporation. If Avalon decides to seek such an amendment, it will be required to make an offer to redeem its outstanding shares of Class A common stock with funds from the trust account in connection with adopting such amendment, which may significantly reduce the amount of funds available to Beneficient should the Avalon Business Combination be consummated and/or hinder Avalon's ability to maintain its listing on Nasdaq. If the Avalon Business Combination is not consummated within the time period required by Avalon's governing documents, Avalon will be forced to cease operations except for the purpose of winding up and returning any funds that remain in its trust account to its public stockholders. In such a case, the Avalon Business Combination would not be consummated.

On January 11, 2023, Avalon received a notice from the Listing Qualifications Department of Nasdaq stating that Avalon failed to hold an annual meeting of stockholders within 12 months after its fiscal year ended December 31, 2021, as required by Nasdaq Listing Rule 5620(a). In accordance with Nasdaq Listing Rule 5810(c)(2)(G), Avalon had 45 calendar days (or until February 27, 2023) to submit a plan to regain compliance and, if Nasdaq accepts the plan, Nasdaq may grant Avalon up to 180 calendar days from its fiscal year end, or until June 29, 2023, to regain compliance. Avalon has not announced whether Nasdaq has accepted its plan to regain

compliance. If the Avalon Business Combination is consummated, there can be no assurance that the combined company maintains its listing on Nasdaq. Any projected valuations of Beneficient in connection with this Disclosure Statement and Second Amended Plan are predicated on Beneficient being publicly listed. If Beneficient is not publicly listed, there is no assurance that the projected valuations will be accurate.

Furthermore, Beneficient and Avalon do not intend to close the Avalon Business Combination unless the combined company is able to fall outside of the definition of “investment company” for purposes of the 1940 Act and, therefore, the provisions of the 1940 Act, after the Registration Statement is effective. The post-transaction company intends to rely on the Section 3(c)(3) exception under the 1940 Act applicable to banks and insurance companies as Ben LP’s subsidiary, BFF, is operating under a trust company charter from the Kansas State Bank Commissioner as a fiduciary financial institution within the state of Kansas. If Beneficient loses its Kansas trust company charter for any reason, then the combined company may not fall outside of the definition of “investment company” for 1940 Act purposes, and as a result, the Avalon Business Combination may not be closed.

If the Avalon Business Combination is not consummated for any of the foregoing reasons or otherwise, or New Beneficient is delisted from Nasdaq, the Wind Down Trustee’s ability to monetize the Wind Down Trust’s interests in New Beneficient could be materially impaired.

3. The Wind Down Debtors May Not Realize a Significant Return on Their FOXO Interests.

The Company has contributed approximately \$20 million to FOXO. Based on the closing price of the FOXO shares on April 14, 2023 of \$0.71 per share, the Debtors’ ownership interest in FOXO had a market value of approximately \$3.266 million. In addition, FOXO’s business and prospectus are subject to numerous risks and uncertainties, which are described in the Joint Proxy Statement/Consent Solicitation Statement/ Prospectus filed by FOXO with the SEC on August 30, 2022, which Holders of Claims and Interests are urged to read. The trading price of the FOXO shares may further decline based on the performance of the company and other factors. As a result, there can be no assurance that the Wind Down Trust will realize a significant return on its interests in FOXO.

4. The Wind Down Debtors May Remain Under Investigation by the SEC and the Debtors are Unable to Predict the Outcome of Such Matter.

As discussed in Article V.A.1 of this Disclosure Statement, on October 6, 2020, the Company received a subpoena to produce documents from the Chicago office of the SEC’s Division of Enforcement, informing the Company of the existence of a non-public, fact-finding investigation into the Company. Since the initial subpoena, the Company has received twenty-one subsequent subpoenas from the SEC for additional information. The requested information from the SEC has related to the Company’s securities, including the Bonds (and the marketing, selling, advertising, sellers, and purchasers of such), disclosures, and various accounting matters; information related to documents and statements referenced in the Company’s SEC filings, including consolidation, valuations, retained professionals and related communications; information related to the Company’s relationship and communications with Beneficient and

certain other parties, including negotiations and agreements; and information related to firm-wide policies and practices generally. The Debtors are cooperating with the SEC in connection with its investigation. Investigations of this nature are inherently uncertain, and their results cannot be predicted. Regardless of the outcome, the SEC Investigation may have an adverse impact on the Debtors or Wind Down Debtors, including because of fines, legal costs, other expenses, diversion of management resources, and other factors.

5. Failure to Comply with Applicable Federal Securities Laws Could Materially and Adversely Affect the Wind Down Trust.

(a) Transfer of Assets Into a Newly-Formed Liquidating Trust

The Second Amended Plan provides that the Debtors' interests in the Wind Down Trust Assets, including the Debtors' interests in Beneficient and FOXO, will be transferred to the Wind Down Trust, which will be a newly-formed liquidating trust, and such transfer is intended to enable the Wind Down Trust and the Debtors to fall within an exception to registration for companies that are dissolving, in accordance with the Liquidating Company Exception. Such companies' activities are restricted to those that are "merely incidental" to their dissolution. Accordingly, the purpose of the Wind Down Trust, including the Portfolio Co. and the Litigation Trust, is to liquidate the assets and distribute the same to interest holders. In addition, the Wind Down Trust will have a term restricted to the timeframe necessary to liquidate the assets, which could be, relative to the assets held by the Portfolio Co., until all of the Policies mature. Holding the Policies until maturity could be necessary to liquidate the assets without incurring a significant reduction in the total gross amount, and net present value, of the liquidation proceeds that are realizable from the Policies. Based on the SEC Staff's guidance, additional restrictions will be placed on the Wind Down Trust's activities and operations. For example, in granting relief from registration requirements in the past where the interests in the dissolving company will be freely transferrable, the staff of the SEC has imposed various conditions on the company and the interests. In order to satisfy these conditions, should the interests in the Wind Down Trust become freely transferable, none of the interests issued by the Wind Down Trust (including the Litigation Trust and the Portfolio Co.) will be listed on any securities exchange or quoted on Nasdaq or similar platform. Further, the Wind Down Trust will not engage the services of a market maker or otherwise facilitate the development of an active trading market for or promote sales of its interests or the interests in the Liquidation Trust or the Portfolio Co., or collect or publish information regarding the prices at which any of those securities are traded (other than to the extent required to be disclosed in any required public filings or in reports required to be submitted to interest holders under applicable law or pursuant to the Second Amended Plan or the Wind Down Trust Agreement).

As a general matter, the 1940 Act's registration requirements do not apply to a company's activities that are merely incidental to its dissolution. The SEC Staff has issued guidance regarding the use of liquidating trusts and similar entities for this purpose. Although the Second Amended Plan is intended to be generally consistent with the spirit of SEC Staff's guidance regarding liquidating trusts, this guidance is based in large part on specific factual situations, which differ, in some ways significantly, from the factual situations relevant to the Wind Down Trust and the Second Amended Plan. Further, much of this guidance was published years ago, and there appears to be no guidance from the SEC Staff that applies directly to the present factual situation. No assurance can be given that the SEC or the SEC Staff will concur with the Second Amended Plan's

approach, or the Debtors' analysis, conclusions or approach, regarding the Wind Down Trust's compliance with the 1940 Act, and if the SEC or the SEC Staff disagrees with any of the foregoing, the SEC or the SEC Staff might take the position that the Wind Down Trust or relevant portions of the Second Amended Plan do not comply with, or do not contemplate activities that are or would be in compliance with, the 1940 Act, which could have material adverse consequences on the Wind Down Trust. In light of this, the Second Amended Plan provides that, if it becomes necessary for 1940 Act compliance purposes to change the organization, operations and/or activities of the Wind Down Trust, the Wind Down Trustee will attempt to do so in a way to preserve the economic benefits of ownership of Wind Down Trust to the maximum extent possible. Such changes may include restrictions that would affect the transferability of the New WDT Interests.

If the Wind Down Trust is not deemed to fall within the Liquidating Company Exception, then it may be required to register under the 1940 Act, which imposes significant legal and operational restrictions on investment companies and would prevent the Wind Down Trust from operating as described in the Second Amended Plan.

(b) Compliance with the 1940 Act

The Wind Down Debtors and Wind Down Trust have no current intention to register as an investment company or be required to do so. A determination that GWGH, the Wind Down Debtors or Wind Down Trust are unregistered investment companies under the 1940 Act would have serious adverse consequences. If at any time it were established that GWGH, the Wind Down Debtors or Wind Down Trust had been operating as an investment company or plan to operate as such in violation of the registration requirements of the 1940 Act, there would be a risk, among other material adverse consequences, that GWGH, the Wind Down Debtors or Wind Down Trust: (i) could become subject to SEC investigation and enforcement actions, including monetary penalties, disgorgement, injunctive relief, industry bars, and receivership or similar action, (ii) would be unable to enforce contracts with third parties or that third parties could seek to obtain rescission of transactions with such company undertaken during the period in which it was established that such company was an unregistered investment company, (iii) would face adverse action from other regulatory authorities; and (iv) potentially be subject to related litigation (which could include a private right of action for 1940 Act violations). Such developments would have material and adverse consequences for GWGH, the Wind Down Debtors or Wind Down Trust, resulting in, among other things, a breach of applicable contracts.

Further, on occasion, the SEC has attempted to regulate the purchase of non-variable universal life insurance policies as transactions in securities under federal securities laws. In July 2010, the SEC issued a Staff Report of its Life Settlement Task Force. In that report, the SEC Staff recommended that certain types of purchased insurance policies be classified as securities. The SEC has not taken any position on the Staff Report, and there is no indication if the SEC will take any action to implement the recommendations of the Staff Report. In addition, there have been several federal court cases in which transactions involving the purchase and fractionalization of life insurance policies have been held to be transactions in securities under the Securities Act.

The Debtors believe that the matters discussed in the Staff Report and existing case law do not impact its current business model because the life insurance policies the Debtors hold are distinguishable from those cases that have been held by courts, and advocated by the Staff Report,

to be transactions in securities. For example, the Debtors are not involved in the fractionalization of life insurance policies.

(c) *Enforcement of Securities Laws*

The federal securities laws grant the SEC broad administrative powers, including the power to limit or restrict a company from conducting activities in the event it fails to comply with applicable federal securities laws. Additional sanctions that may be imposed for failure to comply with applicable requirements include the prohibition of individuals from associating with an unregistered investment company, or participating in the financial services industry, the revocation of registrations and licenses, significant monetary penalties, disgorgement of gains, receivership or similar action, cease-and-desist orders and other censures. The SEC may bring civil actions against companies that violate the federal securities laws, and seek injunctions, damages or other relief, in a U.S. district court or before an administrative law judge. State regulators have the authority to conduct investigations and bring proceedings against unregistered investment companies and other companies that violate applicable state securities laws in certain circumstances. Even if an investigation or proceeding does not result in a sanction or the sanction imposed against an unregistered investment company or its personnel by the SEC or other authority, or resulted in relatively small monetary penalties and similar sanctions, the costs of responding to the investigation and/or the adverse publicity relating to the investigation, proceeding or imposition of these sanctions could harm the company's reputation and could materially and adversely affect its financial condition.

In addition, even in the absence of a regulatory proceeding or similar action, any perceived or actual breach of compliance with the federal securities laws by a person could have a significant impact on that person's reputation, require the person to expend significant funds to remedy problems caused by breaches and to avert further breaches or to defend against allegations of the same, and expose the person to legal risk, including litigation, and potential liability, which could materially and adversely affect its financial condition.

6. The New WDT Interests Will Not Be Transferrable Initially And May Not Become Transferrable in the Future.

Historically, securities of GWGH have been listed on Nasdaq or traded over the counter. In an effort to fall within the Liquidating Company Exception, none of the interests issued by the Wind Down Trust will be listed on any securities exchange or quoted on Nasdaq or similar platform. To the contrary, the Wind Down Trust Agreement will provide that the New WDT Interests may not be transferred, sold, pledged or otherwise disposed of, or offered for sale, except for transfers by will, intestacy or operation of law. Although the Wind Down Trustee may determine in its sole discretion to take such actions that are necessary or reasonably advisable (including, without limitation, completing a registration under the Securities Exchange Act) to modify or remove any contractual restrictions on transferability of the New WDT Interests, the Wind Down Trustee will be under no obligation to take any of these actions and no assurance can be given that the New WDT Interests will become transferrable in the future.

7. The Estimated Valuations of the Expected Wind Down Trust Assets Have Been Completed with Limited Information and Are Inherently Uncertain.

The estimated valuations of the expected Wind Down Trust Assets appearing elsewhere in this Disclosure Statement, including the Valuation Analysis and Liquidation Analysis, reflect estimates of the future value based on limited information available to the Debtors as of the date of this Disclosure Statement. The estimated valuations reflect numerous estimates and assumptions with respect to general business, economic, industry, regulatory, environmental, market and financial conditions and trends and other future events, as well as matters specific to the Wind Down Trust Assets, all of which are difficult to predict and many of which are beyond the Debtors' control.

There can be no assurance that our actual results will be consistent with these estimated valuations. Realizing the value of the Wind Down Trust Assets may take multiple years and such estimated valuations, by their nature, become subject to greater uncertainty with each succeeding year. In addition, whether actual financial results, litigation and other developments will be consistent with the Debtors' expectations and assumptions as reflected in the estimated valuations depends on various factors, many of which are outside our control, including but not limited to those stated elsewhere in this "Risk Factors" section and the uncertainties set forth or referred to in Article II of this Disclosure Statement, respectively. **Unfavorable changes in any of these or other factors, most of which are beyond our control, could adversely affect the value of the Wind Down Trust Assets and cause actual results to differ materially from the estimated valuations contained in this Disclosure Statement.**

C. Disclosure Statement Disclaimer

1. Information Contained in This Disclosure Statement Is Solely for Soliciting Votes.

The information contained in this Disclosure Statement is for the purposes of soliciting votes on the Second Amended Plan and may not be relied upon for any other purpose.

2. This Disclosure Statement Was Not Approved by the United States SEC or Any Other Regulatory Authority.

This Disclosure Statement was not filed with the SEC under the federal securities laws or applicable state securities laws. Neither the SEC nor any state regulatory authority has passed upon the accuracy or adequacy of this Disclosure Statement, or the exhibits or the statements contained in this Disclosure Statement. Any representation to the contrary is unlawful.

3. No Legal or Tax Advice Is Provided to You by this Disclosure Statement. This Disclosure Statement Is Not Legal Advice to You.

The contents of this Disclosure Statement should not be construed as legal, business, or tax advice. Each Holder of a Claim or an Interest should consult his or her own legal counsel, accountant, or other applicable advisor with regard to any legal, tax, and other matters concerning his or her Claim or Interest. This Disclosure Statement may not be relied upon for any tax advice.

4. No Admissions Made.

The information and statements contained in this Disclosure Statement will neither (a) constitute an admission of any fact or liability by any entity (including, without limitation, the Debtors) nor (b) be deemed evidence of the tax or other legal effects of the Second Amended Plan on the Debtors, the Holders of Allowed Claims or Allowed Interests, or any other parties in interest.

5. Failure to Identify Litigation Claims or Projected Objections.

No individual should rely on the fact that a particular litigation claim or projected objection to a particular Claim or Interest is, or is not, identified in this Disclosure Statement. The Debtors may seek to investigate Claims and Interests and may object to Claims or Interests after the Confirmation or Effective Date of the Second Amended Plan irrespective of whether this Disclosure Statement identifies such Claims or Interests or objections to such Claims or Interests.

6. No Waiver of Right to Object or Right to Recover Transfers and Assets.

The vote by a Holder of a Claim or Interest for or against the Second Amended Plan does not constitute a waiver or release of any claims, causes of action, or rights of the Debtors (or any entity, as the case may be) to object to that Holder's Claim or Interest, or recover any preferential, fraudulent, or other voidable transfer of assets, regardless of whether any claims or causes of action of the Debtors or their respective Estates are specifically or generally identified in this Disclosure Statement.

7. Information Was Provided by the Debtors and Was Relied Upon by the Debtors' Advisors.

The Debtors' advisors have relied upon information provided by the Debtors in connection with the preparation of this Disclosure Statement. Although the Debtors' advisors have performed certain limited due diligence in connection with the preparation of this Disclosure Statement, they have not verified independently the information contained in this Disclosure Statement.

8. Potential Exists for Inaccuracies, and the Debtors Have No Duty to Update.

The Debtors make the statements contained in this Disclosure Statement as of the date of this Disclosure Statement, unless otherwise specified in this Disclosure Statement, and the delivery of this Disclosure Statement after the date of this Disclosure Statement does not imply that there has not been a change in the information set forth in this Disclosure Statement since that date. While the Debtors have used their reasonable business judgment to ensure the accuracy of all of the information provided in this Disclosure Statement and in the Second Amended Plan, the Debtors nonetheless cannot, and do not, confirm the current accuracy of all statements appearing in this Disclosure Statement. Further, although the Debtors may subsequently update the information in this Disclosure Statement, the Debtors have no affirmative duty to do so unless ordered to do so by the Bankruptcy Court.

9. No Representations Outside this Disclosure Statement Are Authorized.

Neither the Bankruptcy Court nor the Bankruptcy Code authorizes representations concerning or relating to the Debtors, the Chapter 11 Cases, or the Second Amended Plan are, other than as set forth in this Disclosure Statement. In arriving at your decision, you should not rely upon any representations or inducements made to secure your acceptance or rejection of the Second Amended Plan that are other than as contained in, or included with, this Disclosure Statement. You should promptly report unauthorized representations or inducements to counsel for the Debtors.

IX. SOLICITATION, VOTING PROCEDURES AND CONFIRMATION HEARING

This Disclosure Statement, which is accompanied by a Ballot to be used for voting on the Second Amended Plan, is being distributed to the Holders of Claims and Interests in Classes 3, 4(a), 8, 9 and 10, which are entitled to vote to accept or reject the Second Amended Plan. The procedures and instructions for voting and related deadlines are set forth in the exhibits annexed to the Disclosure Statement Order, which is attached hereto as **Exhibit B**.

The Disclosure Statement Order is incorporated herein by reference and should be read in conjunction with this Disclosure Statement in formulating a decision to vote to accept or reject the Second Amended Plan.

THE DISCUSSION OF THE SOLICITATION AND VOTING PROCESS SET FORTH IN THIS DISCLOSURE STATEMENT IS ONLY A SUMMARY.

PLEASE REFER TO THE DISCLOSURE STATEMENT ORDER ATTACHED HERETO AS EXHIBIT B FOR A MORE COMPREHENSIVE DESCRIPTION OF THE SOLICITATION AND VOTING PROCESS.

A. Holders of Claims and Interests Entitled to Vote on the Second Amended Plan

Under the provisions of the Bankruptcy Code, not all Holders of claims against or interests in a debtor are entitled to vote on a chapter 11 plan. The table in Article III.C of this Disclosure Statement, entitled “Am I entitled to vote on the Second Amended Plan?” provides a summary of the status and voting rights of each Class (and, therefore, of each Holder within such Class absent an objection to the Holder’s Claim or Interest) under the Second Amended Plan.

As shown in the table, the Debtors are soliciting votes to accept or reject the Second Amended Plan only from Holders of Claims or Interests in Classes 3, 4(a), 8, 9 and 10 (the “Voting Classes”). The Holders of Claims and Interests in the Voting Classes are Impaired under the Second Amended Plan and may, in certain circumstances, receive a distribution under the Second Amended Plan. Accordingly, Holders of Claims and Interests in the Voting Classes have the right to vote to accept or reject the Second Amended Plan.

The Debtors are *not* soliciting votes on the Second Amended Plan from Holders of Claims or Interests in Classes 1, 2, 4(b), 5, 6, and 7. Additionally, the Disclosure Statement Order provides that certain Holders of Claims or Interests in the Voting Classes, such as those Holders whose

Claims or Interests have been Disallowed or are subject to a pending objection (including objections filed by the April 26 deadline set forth in the Disclosure Statement Order), are not entitled to vote to accept or reject the Second Amended Plan.

B. Voting Record Date

The Voting Record Date is February 24, 2023. The Voting Record Date is the date on which it will be determined which Holders of Claims and Interests in the Voting Classes are entitled to vote to accept or reject the Second Amended Plan and whether Claims have been properly assigned or transferred under Bankruptcy Rule 3001(e) such that an assignee or transferee, as applicable, can vote to accept or reject the Second Amended Plan as the Holder of a Claim or Interest in Classes 3, 4(a), 8, 9 and 10.

C. Voting on the Second Amended Plan

The Voting Deadline is May 31, 2023 at 4:00 p.m. (prevailing Central Time). To be counted as votes to accept or reject the Second Amended Plan, all Holders of Allowed Claims and Interests entitled to vote on the Second Amended Plan must complete, execute, and return their Ballots so that they are **actually received** by the Notice and Solicitation Agent pursuant to the Solicitation and Voting Procedures on or before **May 31, 2023 at 4:00 p.m. prevailing Central Time** (the “Voting Deadline”).

To vote, complete, sign, and date your Ballot and return it (with an original signature) *promptly* in the reply envelope enclosed with your Ballot or to one of the below addresses, via eBallot portal, or via electronic mail as set forth below. Certain beneficial holders of Claims and Interests will receive separate voting instructions from their respective banks and/or brokerages.

Via E-Ballot Portal. Ballots may be submitted via an electronic Ballot through the Voting Agent’s on-line electronic Ballot submission portal at www.DonlinRecano.com/clients/gwg/vote by no later than the Voting Deadline. Any failure to follow the voting instructions included with the Ballot may disqualify your Ballot and your vote.

OR

By First Class Mail to:

**GWG HOLDINGS, INC., ET AL. Balloting
Center
c/o Donlin Recano Company
Attn: Voting Department
P.O. Box 199043 Blythebourne Station
Brooklyn, NY 11219**

By Hand Delivery or Overnight Mail to:

**GWG HOLDINGS, INC., ET AL. Balloting
Center**

**c/o Donlin Recano Company
Attn: Voting Department
6201 15th Ave
Brooklyn, NY 11219**

OR

Via Electronic Mail. Complete, sign, and date the Ballot and email a scanned copy of the Ballot in a universally viewable file format such as .PDF to GWGVote@donlinrecano.com.

PLEASE SELECT JUST ONE OPTION TO VOTE.

IF YOU HAVE ANY QUESTIONS ABOUT THE SOLICITATION OR VOTING PROCESS, PLEASE CONTACT THE NOTICE AND SOLICITATION AGENT TOLL FREE AT (888) 508-2507 (TOLL-FREE) OR VIA ELECTRONIC MAIL TO GWGINFO@DONLINRECANO.COM.

D. Ballots Not Counted

The following Ballots shall not be counted in determining the acceptance or rejection of the Second Amended Plan: (a) any Ballot (other than a Master Ballot) that partially rejects and partially accepts the Second Amended Plan; (b) any Ballot (other than a Master Ballot) that both accepts and rejects the Second Amended Plan; (c) any Ballot not marked to accept or reject the Second Amended Plan, (d) any Beneficial Holder Ballot (other than a Pre-Validated Beneficial Holder Ballot) submitted directly to the Notice and Solicitation Agent; (e) any Ballot sent to the Debtors, the Debtors' agents (other than the Notice and Solicitation Agent) the Debtors' advisors, or any other party other than the Notice and Solicitation Agent; (f) any Ballot that is not actually received by the Notice and Solicitation Agent by the Voting Deadline (unless the Debtors determine otherwise or as permitted by the Bankruptcy Court); (g) any Ballot sent via facsimile or other unapproved means of delivery; (h) any Ballot that is illegible or contains insufficient information to permit the identification of the Holder of the Claim or Interest, or the Claim or Interest being voted; (i) any Ballot cast by a party that does not hold a Claim or Interest in the Class indicated on the Ballot; (j) any Ballot submitted by a Holder not entitled to vote pursuant to the Second Amended Plan; (k) any Ballot superseded by a later, timely submitted valid Ballot; and (l) any unsigned Ballot (for the avoidance of doubt, Ballots validly submitted through the E-Ballot Portal will be deemed signed). The method of delivery of Ballots to be sent to the Notice and Solicitation Agent is at the election and risk of each Holder. Except as otherwise provided, a Ballot will be deemed delivered only when the Notice and Solicitation Agent actually receives the properly executed Ballot. **Please refer to the Disclosure Statement Order for additional requirements with respect to voting to accept or reject the Second Amended Plan.**

ANY BALLOT RECEIVED AFTER THE VOTING DEADLINE OR THAT IS OTHERWISE NOT IN COMPLIANCE WITH THE DISCLOSURE STATEMENT ORDER WILL NOT BE COUNTED.

X. CONFIRMATION OF THE SECOND AMENDED PLAN

A. Requirements for Confirmation of the Second Amended Plan

The requirements for Confirmation of the Second Amended Plan pursuant to section 1129 of the Bankruptcy Code include: (1) the Second Amended Plan is accepted by all Impaired Classes of Claims or Interests, or if rejected by an Impaired Class, the Second Amended Plan “does not discriminate unfairly” and is “fair and equitable” as to the rejecting Impaired Class; (2) the Second Amended Plan is feasible; and (3) the Second Amended Plan is in the “best interests” of Holders of Claims or Interests.

At the Confirmation Hearing, the Bankruptcy Court will determine whether the Second Amended Plan satisfies all of the requirements of section 1129 of the Bankruptcy Code. The Debtors believe that: (1) the Second Amended Plan satisfies, or will satisfy, all of the necessary statutory requirements of chapter 11 for plan confirmation; (2) the Debtors have complied, or will have complied, with all of the necessary requirements of chapter 11 for plan confirmation; and (3) the Second Amended Plan has been proposed in good faith.

1. Best Interests of Creditors

Often called the “best interests” test, section 1129(a)(7) of the Bankruptcy Code requires that a bankruptcy court find, as a condition to confirmation, that a chapter 11 plan provides, with respect to each impaired class, that each holder of a claim or an equity interest in such impaired class either (1) has accepted the plan or (2) will receive or retain under the plan property of a value that is not less than the amount that the non-accepting holder would receive or retain if the debtors liquidated under chapter 7.

The Debtors, with the assistance of the Debtors’ advisors, have prepared a liquidation analysis (the “Liquidation Analysis”) attached hereto as **Exhibit E**. The Debtors believe that liquidation of the Debtors’ businesses under chapter 7 of the Bankruptcy Code would result in substantial diminution in the value to be realized by Holders of Claims and Interests as compared to distributions contemplated under the Second Amended Plan. Consequently, the Debtors believe that Confirmation of the Second Amended Plan will provide a substantially greater return to Holders of Claims and Interests than would a liquidation under chapter 7 of the Bankruptcy Code.

2. Feasibility

The Bankruptcy Code requires that to confirm a chapter 11 plan, the Bankruptcy Court must find that confirmation of such plan is not likely to be followed by the liquidation or the need for further financial reorganization of the debtor, unless contemplated by the plan. The Second Amended Plan provides for the orderly liquidation and distribution of the Debtors’ remaining assets over time. Accordingly, the Debtors believe that all Second Amended Plan obligations will be satisfied without the need for further reorganization of the Debtors.

3. Acceptance by Impaired Classes

The Bankruptcy Code requires, as a condition to confirmation, except as described in the following section, that each class of claims or equity interests impaired under a plan, accept the

plan. A class that is not “impaired” under a plan is deemed to have accepted the plan and, therefore, solicitation of acceptances with respect to such a class is not required.

Section 1126(c) of the Bankruptcy Code defines acceptance of a plan by a class of impaired claims as acceptance by holders of at least two-thirds in dollar amount and more than one-half in a number of allowed claims in that class, counting only those claims that have *actually* voted to accept or to reject the plan. Thus, a Class of Claims or Interests will have voted to accept the Second Amended Plan only if two-thirds in amount and a majority in number of the Allowed Claims or Interests in such Class that vote on the Second Amended Plan actually cast their ballots in favor of acceptance.

Section 1126(d) of the Bankruptcy Code defines acceptance of a plan by a class of impaired equity interests as acceptance by holders of at least two-thirds in amount of allowed interests in that class, counting only those interests that have *actually* voted to accept or to reject the plan. Thus, a Class of Interests will have voted to accept the Second Amended Plan only if two-thirds in amount of the Allowed Interests in such class that vote on the Second Amended Plan actually cast their ballots in favor of acceptance.

Pursuant to Article III.E of the Second Amended Plan, if a Class contains Claims or Interests that are eligible to vote and no Holders of Claims or Interests eligible to vote in such Class vote to accept or reject the Second Amended Plan, the Holders of such Claims or Interests in such Class shall be deemed to have accepted the Second Amended Plan.

B. Confirmation Without Acceptance by All Impaired Classes

Section 1129(b) of the Bankruptcy Code allows a bankruptcy court to confirm a plan even if all impaired classes have not accepted it; *provided* that the plan has been accepted by at least one impaired class. Pursuant to section 1129(b) of the Bankruptcy Code, notwithstanding an impaired class’s rejection or deemed rejection of the plan, the plan will be confirmed, at the plan proponent’s request, in a procedure commonly known as a “cramdown” so long as the plan does not “discriminate unfairly” and is “fair and equitable” with respect to each class of claims or equity interests that is impaired under, and has not accepted, the plan.

If any Impaired Class rejects the Second Amended Plan, the Debtors reserve the right to seek to confirm the Second Amended Plan utilizing the “cramdown” provision of section 1129(b) of the Bankruptcy Code. To the extent that any Impaired Class rejects the Second Amended Plan or is deemed to have rejected the Second Amended Plan, the Debtors may request Confirmation of the Second Amended Plan, as it may be modified from time to time, under section 1129(b) of the Bankruptcy Code. The Debtors reserve the right to alter, amend, modify, revoke, or withdraw the Second Amended Plan or any Plan Supplement document, including the right to amend or modify the Second Amended Plan or any Plan Supplement document to satisfy the requirements of section 1129(b) of the Bankruptcy Code.

1. No Unfair Discrimination

The “unfair discrimination” test applies to classes of claims or interests that are of equal priority and are receiving different treatment under a plan. The test does not require that the treatment be the same or equivalent, but that treatment be “fair.” In general, bankruptcy courts

consider whether a plan discriminates unfairly in its treatment of classes of claims or interests of equal rank (*e.g.*, classes of the same legal character). Bankruptcy courts will take into account a number of factors in determining whether a plan discriminates unfairly. A plan could treat two classes of unsecured creditors differently without unfairly discriminating against either class.

2. Fair and Equitable Test

The “fair and equitable” test applies to classes of different priority and status (*e.g.*, secured versus unsecured) and includes the general requirement that no class of claims receive more than 100 percent of the amount of the allowed claims in the class. As to the dissenting class, the test sets different standards depending upon the type of claims or equity interests in the class.

C. Valuation of the Wind Down Trust Assets

In conjunction with the Second Amended Plan, the Debtors have determined to estimate the post-Confirmation value of the Wind Down Trust Assets. Accordingly, the Debtors, with the assistance of their advisors, have prepared a valuation analysis of the Wind Down Trust Assets (the “Valuation Analysis”), attached hereto as **Exhibit C**.

For the avoidance of doubt, the Bondholder Committee does not adopt, or express any position, with respect to any portion of the Debtors’ Valuation Analysis and the Bondholder Committee’s lack of objection shall in no way be deemed in any way to prejudice or otherwise impair (i) any claims or causes of action that may be pursued by the Litigation Trust or (ii) the Bondholder Committee’s right or ability to object to any settlements with respect to which the Debtors may seek approval of the Bankruptcy Court.

XI. CERTAIN SECURITIES LAW MATTERS

The Debtors intend that the Wind Down Trust will be organized in compliance with applicable law such that the New WDT Interests will not be treated as securities. As a result, the Debtors do not believe that registration under the Securities Act and applicable state law in connection with the issuance and distribution of the New WDT Interests or an exemption from such registration requirements is required. However, to the extent that the issuance and distribution of the New WDT Interests pursuant to the Second Amended Plan are deemed securities, the issuance and distribution thereof would be exempt from, among other things, the registration requirements of Section 5 of the Securities Act and any other applicable U.S., state, or local law requiring registration prior to the offering, issuance, distribution, or sale of securities in accordance with, and pursuant to, Section 1145 of the Bankruptcy Code and to the extent such exemption was not available, then such New WDT Interests would be offered, issued and distributed under the Second Amended Plan pursuant to other applicable exemptions from registration under the Securities Act and any other applicable securities laws. Section 1145(a) of the Bankruptcy Code exempts securities issued pursuant to a plan from registration under the Securities Act, or any state law requiring registration for the sale or offering of securities, provided certain conditions are met, except for securities issued to an “underwriter,” as defined in Section 1145(b) of the Bankruptcy Code. Subsequent transfers of the securities by holders that are not “underwriters” would, as a matter of federal securities law, generally be exempt from federal securities registration requirements.

Section 1145(a) of the Bankruptcy Code generally exempts from federal and state registration requirements the issuance of securities if the following conditions are satisfied:

- (i) the securities are offered or sold under a chapter 11 plan by (x) a debtor, (y) one of its affiliates participating in a joint plan with the debtor, or (z) a successor to a debtor under the plan; and
- (ii) the securities are issued in exchange for a claim against or interest in the debtor or such affiliate, or are issued principally in such exchange and partly for cash or property.

Section 1145(b)(1) of the Bankruptcy Code defines “underwriter” as one who (A) purchases a claim or interest with a view to distribution of any security to be received in exchange for the claim or interest, (B) offers to sell securities issued under a plan for the holders of such securities, (C) offers to buy securities issued under a plan from the holders receiving such securities, if the offer to buy is made with a view to distribution of such securities and under an agreement made in connection with the plan, with the consummation of the plan, or with the offer or sale of securities under the plan, or (D) is an issuer of the securities within the meaning of Section 2(a)(11) of the Securities Act.

Section 2(a)(11) of the Securities Act defines an “issuer” to include any person directly or indirectly controlling or controlled by the issuer, or any person under direct or indirect common control with the issuer. “Control,” as defined in Rule 405 under the Securities Act, means the possession, direct or indirect, of the power to direct or cause the direction of the management and policies of a person, whether through the ownership of voting securities, by contract, or otherwise. Section 1145(b)(1)(D) therefore applies to persons considered “affiliates” of the issuer, as defined in Rule 144 under the Securities Act.

Were the New WDT Interests to be deemed securities, the Debtors believe that the exchange of New WDT Interests for Claims against the Debtors under the circumstances provided in the Second Amended Plan would generally satisfy the requirements of Section 1145(a) of the Bankruptcy Code. Any subsequent transfers of securities not issuable pursuant to Section 1145(a) of the Bankruptcy Code, because of the applicability of Section 1145(b) of the Bankruptcy Code, would require registration under the Securities Act or an exemption from registration under the Securities Act.

Were the New WDT Interests to be deemed securities, the New WDT Interests issued pursuant to the Second Amended Plan would be deemed to have been issued in a public offering, except to holders who meet the Section 1145(b) definition of an “underwriter.” In such case, the New WDT Interests would, as matter of federal securities law, be permitted to be resold by a holder, other than such an underwriter, without registration under the Securities Act pursuant to the exemption provided by Section 4(a)(1) of the Securities Act.

Securities held by persons deemed to be “underwriters” under Section 1145(b) of the Bankruptcy Code, as a matter of federal securities law would not be permitted resold under the Securities Act or applicable state securities laws absent an effective registration statement under the Securities Act, or pursuant to an applicable exemption from registration such as Rule 144, and

pursuant to applicable exemptions under state securities laws. Under certain circumstances, such persons might be able to resell their securities pursuant to Rule 144, and in compliance with applicable state securities laws. Generally, Rule 144 provides that persons who are affiliates may resell securities, without being deemed underwriters under the Securities Act, if certain conditions are met. These conditions include: the availability of current public information with respect to the issuer; a limitation as to the amount of securities that may be sold in any three-month period; the requirement that the securities be sold in a “brokers’ transaction” or in a transaction directly with a “market maker”; and the filing of a notice of resale with the SEC.

Notwithstanding the forgoing or anything to the contrary in this Disclosure Statement, the Wind Down Trust Agreement will provide that the New WDT Interests may not be transferred, sold, pledged or otherwise disposed of, or offered for sale, except for transfers by will, intestacy or operation of law. As noted above, the Wind Down Trust will be organized in compliance with applicable law such that the New WDT Interests will not be treated as securities and under such facts the Debtors do not believe that registration under the Securities Act and applicable state law in connection with the issuance and distribution of the New WDT Interests or an exemption from such registration requirements would be required. The Wind Down Trustee will be permitted to determine in its sole discretion to take such actions that are necessary or reasonably advisable (including, without limitation, completing a registration under the Exchange Act) to modify or remove any contractual restrictions on transferability of the New WDT Interests, with any such determination by the Wind Down Trustee, and all costs associated therewith, to be deemed a determination with respect to the monetization of the Wind Down Trust Assets pursuant to Article IV.A.3 of the Second Amended Plan and to be evaluated solely under a reasonable business judgment standard.

XII. CERTAIN UNITED STATES FEDERAL INCOME TAX CONSEQUENCES OF THE SECOND AMENDED PLAN

A. General

The following discussion is a summary of certain U.S. federal income tax consequences of the consummation of the Second Amended Plan to the Debtors and to certain Holders. The following summary does not address the U.S. federal income tax consequences to Holders not entitled to vote to accept or reject the Second Amended Plan. This summary is based on the U.S. Internal Revenue Code of 1986, as amended (“IRC”), the U.S. Treasury Regulations promulgated thereunder (the “Treasury Regulations”), judicial authorities, published administrative positions of the U.S. Internal Revenue Service (the “IRS”), and other applicable authorities (collectively, “Applicable Tax Law”), all as in effect on the date of this Disclosure Statement and all of which are subject to change or differing interpretations, possibly with retroactive effect. Changes in these rules or new interpretations of the rules with retroactive effect could significantly affect the U.S. federal income tax consequences described herein. Due to the lack of definitive judicial and administrative authority in a number of areas, substantial uncertainty may exist with respect to some of the tax consequences described below. No opinion of counsel has been obtained and the Debtors have not requested, and do not intend to seek, a ruling or determination from the IRS as to any of the tax consequences of the Second Amended Plan discussed below. The discussion below is not binding upon the IRS or the courts. No assurance can be given that the IRS would not assert, or that a court would not sustain, a different position than any position discussed herein.

This discussion does not purport to address all aspects of U.S. federal income taxation that may be relevant to certain Holders in light of their individual circumstances. This discussion also does not address tax issues with respect to Non-U.S. Holders (as defined below) or such Holders that are subject to special treatment under the U.S. federal income tax laws (including, for example, accrual-method Holders (as defined below) that prepare an “applicable financial statement” (as defined in section 451 of the IRC), banks, mutual funds, governmental authorities or agencies, pass-through entities, beneficial owners of pass-through entities, subchapter S corporations, dealers and traders in securities, insurance companies, financial institutions, tax-exempt organizations, controlled foreign corporations, passive foreign investment companies, Holders whose functional currency is not the U.S. dollar, U.S. expatriates, broker-dealers, small business investment companies, persons who are related to the Debtors within the meaning of the IRC, persons liable for Medicare tax, alternative minimum tax or minimum tax on book income, persons using a mark-to-market method of accounting, Holders who are themselves in bankruptcy, real estate investment companies and regulated investment companies and those holding, or who will hold, consideration received pursuant to the Second Amended Plan as part of a hedge, straddle, conversion, or other integrated transaction). No aspect of state, local, non-income, or non-U.S. taxation is addressed. Furthermore, this summary assumes that a Holder holds only Claims or Interests in a single Class and holds such Claims or Interests only as “capital assets” (within the meaning of section 1221 of the IRC). This summary also generally assumes, except as discussed below, that the various debt and other arrangements to which the Debtors and Wind Down Debtors are or will be a party will be respected for U.S. federal income tax purposes in accordance with their form, and, to the extent relevant, that the Claims constitute interests in the Debtors “solely as a creditor” for purposes of section 897 of the IRC. This summary does not discuss differences in tax consequences to Holders that act or receive consideration in a capacity other than that of a Holder of a Claim or Interest of the same Class or Classes, and the tax consequences for such Holders may differ materially from that described below. This summary does not address the U.S. federal income tax consequences to Holders (a) whose Claims or Interests are unimpaired or otherwise entitled to payment in full under the Second Amended Plan, or (b) that are deemed to reject the Second Amended Plan.

For purposes of this discussion, a “U.S. Holder” is a Holder of a Claim or Interest (including a beneficial owner of Claims or Interests) that is: (a) an individual citizen or resident of the United States for U.S. federal income tax purposes; (b) a corporation (or other entity treated as a corporation for U.S. federal income tax purposes) created or organized under the laws of the United States, any state thereof or the District of Columbia; (c) an estate the income of which is subject to U.S. federal income taxation regardless of the source of such income; or (d) a trust (i) if a court within the United States is able to exercise primary jurisdiction over the trust’s administration and one or more United States persons (within the meaning of section 7701(a)(30) of the IRC) have authority to control all substantial decisions of the trust or (ii) that has a valid election in effect under applicable Treasury Regulations to be treated as a United States person. For purposes of this discussion, a “Non-U.S. Holder” is any Holder of a Claim or Interest that is neither a U.S. Holder nor a partnership (or other entity treated as a partnership or other pass-through entity for U.S. federal income tax purposes).

If a partnership (or other entity treated as a partnership or other pass-through entity for U.S. federal income tax purposes) is a Holder of a Claim or Interest, the tax treatment of a partner (or other beneficial owner) generally will depend upon the status of the partner (or other beneficial

owner) and the activities of the entity. Partners (or other beneficial owners) of partnerships (or other entities treated as partnerships or other pass-through entities) that are Holders of Claims or Interests should consult their tax advisors regarding the U.S. federal income tax consequences of the Second Amended Plan.

THE FOLLOWING SUMMARY OF CERTAIN U.S. FEDERAL INCOME TAX CONSEQUENCES IS FOR INFORMATIONAL PURPOSES ONLY AND IS NOT A SUBSTITUTE FOR CAREFUL TAX PLANNING AND ADVICE BASED UPON THE INDIVIDUAL CIRCUMSTANCES PERTAINING TO A HOLDER. ALL HOLDERS ARE URGED TO CONSULT THEIR OWN TAX ADVISORS FOR THE U.S. FEDERAL, STATE, LOCAL, AND NON-U.S. TAX CONSEQUENCES OF THE SECOND AMENDED PLAN.

B. Consequences to the Debtors

1. Cancellation of Debt

In general, absent an exception, a taxpayer will realize and recognize cancellation of indebtedness income (“COD Income”) upon satisfaction of its outstanding indebtedness for total consideration less than the amount of such indebtedness. The amount of COD Income, in general, is the excess of (a) the “adjusted issue price” (within the meaning of the Treasury Regulations) of the indebtedness satisfied, over (b) the sum of (i) the issue price of any new debt instruments of the taxpayer issued, (ii) the fair market value of other non-cash consideration (including stock of the taxpayer or a party related to the taxpayer), and (iii) the amount of cash, in each case, given in satisfaction of such indebtedness at the time of the exchange.

A taxpayer will not, however, be required to include COD Income in gross income pursuant to section 108 of the IRC if the taxpayer is under the jurisdiction of a court in a case under chapter 11 of the Bankruptcy Code and the discharge of debt occurs pursuant to that proceeding. Instead, as a consequence of such exclusion, a taxpayer must reduce its NOLs and certain other tax attributes (collectively, “Tax Attributes”) and aggregate tax basis in assets (including the stock of subsidiaries) by the amount of COD Income that it excluded from gross income pursuant to section 108 of the IRC. Such reduction in Tax Attributes and aggregate tax basis occurs only after the tax for the year of the debt discharge has been determined. In general, Tax Attributes and aggregate tax basis will be reduced in the following order: (a) NOLs and NOL carryforwards; (b) general business credit carryovers; (c) minimum tax credit carryovers; (d) capital loss carryovers; (e) tax basis in assets, which includes the stock of subsidiaries (but not below the amount of liabilities to which the debtor remains subject immediately after the discharge); (f) passive activity loss and credit carryovers; and (g) foreign tax credits carryovers. Alternatively, a debtor with COD Income may elect first to reduce the basis of its depreciable assets pursuant to section 108(b)(5) of the IRC, in which case such reduction would not be subject to the limitation described in section (e) of the prior sentence. Interest expense deductions allowable under section 163(j) of the Code (and carryforwards of any such deductions) (“163(j) Deductions”) are not subject to reduction under these rules. Any excess COD Income over the amount of available items described in clauses (a) through (g), above, will generally not give rise to U.S. federal income tax and will generally have no other U.S. federal income tax impact. Where the taxpayer joins in the filing of a consolidated U.S. federal income tax return, applicable Treasury Regulations require, in certain circumstances, that certain tax attributes of other members of the group also be reduced.

The Debtors may realize COD Income in connection with the Second Amended Plan, with an attendant reduction in Tax Attributes (but in the case of tax basis where no election is made to reduce the basis of depreciable assets as described above, only to the extent such tax basis exceeds the amount of the Debtors' liabilities, as determined for these purposes, immediately after the Effective Date). The exact amount of any COD Income that will be realized by the Debtors will not be determinable until the consummation of the Second Amended Plan because the amount of COD Income will depend, in part, on the value of non-cash consideration (including the New WDT Interests), which cannot be determined until after the Second Amended Plan is consummated. As a result, the total amount of reduction in Tax Attributes and aggregate tax basis as a result of the Plan cannot be determined until after the Effective Date.

2. Transfer of Assets to the Wind Down Trust

The Debtors' transfer of assets to the Wind Down Trust will be treated as a fully taxable sale or exchange of the Wind Down Trust Assets. As a result, the Debtors will recognize gain or loss with respect to the Wind Down Trust Assets. The amount of the Debtors' gain or loss on account of such transfer has not been determined, and will depend on the value of such assets on the date of such transfer to the Wind Down Trust relative to the Debtors' adjusted tax basis in such assets on such date.

C. Consequences to Holders of Claims and Interests

1. Realization and Recognition of Gain or Loss, In General

The federal income tax consequences of the implementation of the Second Amended Plan to a Holder of a Claim or Interest will depend, among other things, upon the origin of the Holder's Claim or Interest, when the Holder receives payment in respect of such Claim or Interest, whether the Holder reports income using the accrual or cash method of tax accounting, whether the Holder acquired its Claim or Interest at a discount, whether the Holder has taken a bad debt deduction or worthless security deduction with respect to such Claim or Interest, and whether (as intended and herein assumed) the Second Amended Plan is treated as a plan of liquidation for federal income tax purposes. A Holder of an Interest should consult its tax advisor regarding the timing and amount of any potential worthless stock loss.

Generally, a Holder of an Allowed Claim or Interest will realize gain or loss on the exchange under the Second Amended Plan of its Allowed Claim or Interest for Cash or other property (including any New WDT Interests), in an amount equal to the difference between (i) the sum of the amount of any Cash and the fair market value on the date of the exchange of any other property received by the Holder, including, as discussed below, its respective share of the Wind Down Trust Assets and Initial Litigation Trust Assets (consistent with its economic rights in the trust) (other than any consideration attributable to a Claim for accrued but unpaid interest) and (ii) the adjusted tax basis of the Allowed Claim or Interest exchanged therefor (other than basis attributable to accrued but unpaid interest previously included in the Holder's taxable income).

When gain or loss is recognized as discussed below, such gain or loss may be long-term capital gain or loss if the Claim or Interest disposed of is a capital asset in the hands of the Holder and the Holder's holding period in the Claim or Interest exceeds one year. Each Holder of an

Allowed Claim or Interest should consult its own tax advisor to determine whether gain or loss recognized by such Holder will be long-term capital gain or loss and the specific tax effect thereof on such Holder.

As discussed below, each Holder of an Allowed Claim or Interest that receives a beneficial interest in the Wind Down Trust will be treated for U.S. federal income tax purposes as directly receiving, and as a direct owner of, its respective share of the Wind Down Trust Assets and Initial Litigation Trust Assets (consistent with its economic rights in the trust). Pursuant to the Second Amended Plan, the Wind Down Trustee will in good faith value the assets transferred to the Wind Down Trust, and all parties to the Wind Down Trust or Litigation Trust (including Holders of Claims or Interests receiving New WDT Interests) must consistently use such valuation for all U.S. federal income tax purposes.

A Holder's share of any proceeds received by the Wind Down Trust or Litigation Trust upon the sale or other disposition of the assets of such liquidating trust should not be included, for federal income tax purposes, in the Holder's amount realized in respect of its Allowed Claim or Interest but should be separately treated as amounts realized in respect of such Holder's ownership interest in the underlying assets of the liquidating trust.

A Holder's tax basis in its respective share of the Wind Down Trust Assets or Initial Litigation Trust Assets will equal the fair market value of such respective share, and the Holder's holding period generally will begin the day following the establishment of such liquidating trust.

2. Allocation of Consideration to Interest

In general, to the extent any amount received (whether stock, Cash, or other property) by a Holder of a debt instrument is received in satisfaction of accrued interest during its holding period, such amount will be taxable to the Holder as interest income (if not previously included in the Holder's gross income under the Holder's normal method of accounting). Conversely, a Holder generally recognizes a deductible loss to the extent any accrued interest claimed was previously included in its gross income and is not paid in full. Each Holder of an Allowed Claim or Interest is urged to consult its own tax advisor regarding the allocation of consideration and the taxation or deductibility of unpaid interest for tax purposes.

D. Tax Treatment of a Liquidating Trust and Holders of Beneficial Interests

1. Classification of the Wind Down Trust and Litigation Trust

The Wind Down Trust and Litigation Trust are each intended to qualify as a "liquidating trust" for U.S. federal income tax purposes. In general, a liquidating trust is not a separate taxable entity, but rather is treated for U.S. federal income tax purposes as a "grantor trust" (i.e., all income and loss is taxed directly to the holders of New WDT Interests). However, merely establishing a trust as a liquidating trust does not ensure that it will be treated as a grantor trust for U.S. federal income tax purposes. The IRS, in Revenue Procedure 94-45, 1994-2 C.B. 684, set forth the general criteria for obtaining an IRS ruling as to the grantor trust status of a liquidating trust under a chapter 11 plan. The Wind Down Trust and Litigation Trust will be structured to comply with such general criteria. Pursuant to the Second Amended Plan, and in conformity with Revenue Procedure 94-45, all parties (including, without limitation, the Debtors, the Wind Down Trustee, Holders of Allowed

Claims or Interests, and the holders of New WDT Interests) will be required to treat, for U.S. federal income tax purposes, the Wind Down Trust as a grantor trust of which the holders of New WDT Interests are the owners and grantors. The following discussion assumes that the Wind Down Trust will be so respected for U.S. federal income tax purposes. However, no opinion of counsel has been requested, and the Debtors or Wind Down Trustee may or may not obtain a ruling from the IRS, concerning the tax status of the Wind Down Trust as a grantor trust. Accordingly, there can be no assurance that the IRS would not take a contrary position. If the IRS were to challenge successfully the classification of a Wind Down Trust, the U.S. federal income tax consequences to the Wind Down Trust, the holders of New WDT Interests and the Debtors could vary from those discussed herein (including the potential for an entity-level tax on income of the Wind Down Trust).

2. General Tax Reporting by the Wind Down Trust and Holders of New WDT Interests

For all U.S. federal income tax purposes, all parties (including, without limitation, the Debtors, the Wind Down Trustee, Holders of Allowed Claims or Interests, and the holders of New WDT Interests) must treat the transfer of the Wind Down Trust Assets and the Initial Litigation Trust Assets to the Wind Down Trust or Litigation Trust, as the case may be, in accordance with the terms of the Second Amended Plan. Pursuant to the Second Amended Plan, the Wind Down Trust Assets and the Initial Litigation Trust Assets are treated, for U.S. federal income tax purposes, as having been transferred, subject to any obligations relating to those assets, directly to the Holders of the respective Claims or Interests receiving New WDT Interests (with each Holder receiving an undivided interest in such assets in accordance with their economic interests in such assets), followed by the transfer by the Holders of such assets to the Wind Down Trust or Litigation Trust, as the case may be, in exchange for the New WDT Interests. Accordingly, all parties must treat the Wind Down Trust as a grantor trust of which the Holders of New WDT Interests are the owners and grantors, and treat the holders of New WDT Interests as the direct owners of an undivided interest in the Wind Down Trust Assets and the Initial Litigation Trust Assets, consistent with their economic interests therein, for all U.S. federal income tax purposes.

Allocations of taxable income of the Wind Down Trust among the holder of New WDT Interests is expected to be determined by reference to the manner in which an amount of Cash equal to such taxable income would be distributed (were such Cash permitted to be distributed at such time) if, immediately prior to such deemed distribution, the Wind Down Trust and Litigation Trust had distributed all their assets (valued at their tax book value) to the holders of New WDT Interests, adjusted for prior taxable income and loss and taking into account all prior and concurrent distributions from the Wind Down Trust or Litigation Trust. Similarly, taxable loss of the Wind Down Trust or Litigation Trust is expected to be allocated by reference to the manner in which an economic loss would be borne immediately after a liquidating distribution of the remaining Wind Down Trust Assets and Initial Litigation Trust Assets. The tax book value of the Wind Down Trust Assets and Initial Litigation Trust Assets for this purpose shall equal their fair market value on the date of the transfer of such assets to the Wind Down Trust or Litigation Trust, as the case may be, adjusted in accordance with tax accounting principles prescribed by the IRC, applicable Treasury Regulations, and other applicable administrative and judicial authorities and pronouncements.

As soon as reasonably practicable after the transfer of the Wind Down Trust Assets and Initial Litigation Trust Assets to the Wind Down Trust or Litigation Trust, as the case may be, the Wind Down Trustee shall make a good faith valuation of the Wind Down Trust Assets and Initial Litigation Trust Assets. All parties to the Wind Down Trust (including, without limitation, the Debtors and the holders of New WDT Interests) must consistently use such valuation for all U.S. federal income tax purposes. The valuation will be made available, from time to time, as relevant for tax reporting purposes.

Taxable income or loss allocated to a holder of New WDT Interests will be treated as income or loss with respect to such holder's undivided interest in the Wind Down Trust Assets and Initial Litigation Trust Assets, and not as income or loss with respect to its prior Allowed Claim or Interest. The character of any income and the character and ability to use any loss will depend on the particular situation of the holder of New WDT Interests.

The U.S. federal income tax obligations of a Holder with respect to its New WDT Interest are not dependent on the Wind Down Trust or Litigation Trust distributing any Cash or other proceeds. Thus, a Holder may incur a U.S. federal income tax liability with respect to its allocable share of Wind Down Trust or Litigation Trust income even if the Wind Down Trust or Litigation Trust does not make a concurrent distribution to the Holder. In general, a distribution of Cash by the Wind Down Trust or Litigation Trust will not be separately taxable to a holder of New WDT Interests since the holder is already regarded for federal income tax purposes as owning the underlying assets (and was taxed at the time the cash was earned or received by the Wind Down Trust or Litigation Trust).

The Wind Down Trustee will comply with all applicable governmental withholding requirements. Thus, in the case of any holders of New WDT Interests that are not U.S. persons, the Wind Down Trustee may be required to withhold up to 30% of the income or proceeds allocable to such persons, depending on the circumstances (including whether the type of income is subject to a lower treaty rate). As indicated above, the foregoing discussion of the U.S. federal income tax consequences of the Second Plan does not generally address the consequences to non-U.S. Holders; accordingly, such Holders should consult their tax advisors with respect to the U.S. federal income tax consequences of the Second Plan, including owning an interest in the Wind Down Trust.

The Wind Down Trustee will file with the IRS tax returns for the Wind Down Trust consistent with its classification as a grantor trust pursuant to Treasury Regulation Section 1.671-4(a). The Wind Down Trustee also will send annually to each holder of a New WDT Interest a separate statement regarding the receipts and expenditures of the Wind Down Trust as relevant for U.S. federal income tax purposes and will instruct all such holders to use such information in preparing their U.S. federal income tax returns or to forward the appropriate information to such holder's underlying beneficial holders with instructions to utilize such information in preparing their U.S. federal income tax returns.

3. Non-U.S. Holders of New WDT Interests

As discussed above, all Holders (including Non-U.S. Holders) are required to treat the holders of New WDT Interests as the direct owners of an undivided interest in the Wind Down

Trust Assets and the Initial Litigation Trust Assets, consistent with their economic interests therein, for all U.S. federal income tax purposes. Non-U.S. Holders may be subject to adverse U.S. federal income tax consequences as a result of holding New WDT Interests, including (1) being subject to U.S. federal withholding tax on distributions or allocations of income with respect to the Wind Down Trust Assets or the Initial Litigation Trust Assets, and (2) being treated as engaged in a trade or business in the United States and, as a result, being required to make U.S. income tax return filings and pay U.S. federal income tax on a net basis with respect to income that is effectively connected with such trade or business. Non-U.S. Holders of Allowed Claims or Interests are urged to consult with their tax advisors regarding the U.S. federal income tax consequences of holding New WDT Interests generally, including the possibility of being treated as engaged in a trade or business in the United States and any potential U.S. federal withholding tax on distributions by the Debtors or payments from the Wind Down Trustee.

E. Withholding on Distributions, and Information Reporting

All Distributions to Holders of Allowed Claims or Interests under the Second Amended Plan are subject to any applicable tax withholding, including employment tax withholding. Under federal income tax law, interest, dividends, and other reportable payments may, under certain circumstances, be subject to “backup withholding” at the then applicable withholding rate (currently 24%). Backup withholding generally applies if the Holder (a) fails to furnish its social security number or other taxpayer identification number, (b) furnishes an incorrect taxpayer identification number, (c) fails properly to report interest or dividends, or (d) under certain circumstances, fails to provide a certified statement, signed under penalty of perjury, that the tax identification number provided is its correct number and that it is not subject to backup withholding. Backup withholding is not an additional tax but merely an advance payment, which may be refunded to the extent it results in an overpayment of tax. Certain persons are exempt from backup withholding, including, in certain circumstances, corporations and financial institutions. These categories are very broad; however, there are numerous exceptions. Holders of Allowed Claims or Interests are urged to consult their tax advisors regarding the Treasury Regulations governing backup withholding and whether the transactions contemplated by the Second Amended Plan would be subject to these Treasury Regulations.

In addition, Treasury Regulations generally require disclosure by a taxpayer on its U.S. federal income tax return of certain types of transactions in which the taxpayer participated, including, among other types of transactions, certain transactions that result in the taxpayer’s claiming a loss in excess of specified thresholds. Holders are urged to consult their tax advisors regarding these Treasury Regulations and whether the transactions contemplated by the Second Amended Plan would be subject to these Treasury Regulations and require disclosure on the Holder’s tax returns.

In addition, a Holder of an Allowed Claim or Interest or a holder of a New WDT Interest that is a Non-U.S. Holder may be subject to up to 30% withholding, depending on, among other things, the particular type of income and whether the type of income is subject to a lower treaty rate. As to certain Claims or Interests, it is possible that withholding may be required with respect to distributions by the Debtors even if no withholding would have been required if payment was made prior to the Chapter 11 Cases. A Non-U.S. Holder may also be subject to other adverse consequences in connection with the implementation of the Second Amended Plan. As discussed

above, the foregoing discussion of the U.S. federal income tax consequences of the Second Amended Plan does not generally address the consequences to Non-U.S. Holders. Holders are urged to consult their tax advisors regarding potential withholding on distributions by the Debtors or payments from the Wind Down Trustee.

Dated: April 20, 2023
Houston, Texas

GWG HOLDINGS, INC.
on behalf of itself and its Debtor affiliates.

/s/ Jeffrey S. Stein

Jeffrey S. Stein, as Chief Restructuring Officer, President, Chief Executive Officer and Independent Director of GWG Holdings, Inc.

/s/ Kade Baird

Kade Baird, as designated representative of Bank of Utah, as Indenture Trustee and solely in its capacity as Chair of the Official Committee of Bondholders of GWG Holdings, Inc., *et al.*

/s/ Richard S. Schmidt

Richard S. Schmidt, as Restructuring Manager of L Bond Management, LLC

Prepared by:

JACKSON WALKER LLP

Kristhy M. Peguero (TX Bar No. 24102776)
Matthew D. Cavanaugh (TX Bar No. 24062656)
1401 McKinney Street, Suite 1900
Houston, TX 77010
Telephone: (713) 752-4200
Email: kpeguero@jw.com
mcavanaugh@jw.com

Co-Counsel for the Debtors and Debtors in Possession

KATTEN MUCHIN ROSENMAN LLP

Steven J. Reisman (pro hac vice)
Cindi M. Giglio (pro hac vice)
Marc B. Roitman (pro hac vice)
Jerry L. Hall (pro hac vice)
50 Rockefeller Plaza
New York, NY 10020
Telephone: (212) 940-8800
Email: sreisman@katten.com
cgiglio@katten.com
marc.roitman@katten.com
jerry.hall@katten.com

-and-

Daniel Barnowski (pro hac vice)
2900 K Street NW, Suite 200
Washington, DC 20007
Telephone: (202) 625-3500
Email: dan.barnowski@katten.com

Counsel to Jeffrey S. Stein and Anthony R. Horton, in their capacity as members of the Investigations Committee and Special Committee of the Board of Directors of GWG Holdings, Inc.

MAYER BROWN LLP

Charles S. Kelley (TX Bar No. 11199580)
700 Louisiana Street, Suite 3400
Houston, TX 77002-2730
Telephone: (713) 238-3000
Email: ckelley@mayerbrown.com

-and-

Thomas S. Kiriakos (admitted *pro hac vice*)
Louis S. Chiappetta (admitted *pro hac vice*)
Jamie R. Netznik (admitted *pro hac vice*)
Lisa Holl Chang
Joshua R. Gross (admitted *pro hac vice*)
Jade Edwards
71 S. Wacker Drive
Chicago, IL 60606
Telephone: (312) 782-0600
Email: tkiriakos@mayerbrown.com
lchiappetta@mayerbrown.com
jnetznik@mayerbrown.com
lhollchang@mayerbrown.com
jgross@mayerbrown.com
jmedwards@mayerbrown.com

-and-

Adam C. Paul (admitted *pro hac vice*)
Lucy F. Kweskin (admitted *pro hac vice*)
Ashley Anglade
1221 Avenue of the Americas
New York, NY 10020-1001
Telephone: (212) 506-2500
Email: apaul@mayerbrown.com
lkweskin@mayerbrown.com
aanglade@mayerbrown.com

Counsel for the Debtors and Debtors in Possession

Creditor Proponents:

PORTER HEDGES LLP

Eric M. English (TX Bar No. 24062714)
M. Shane Johnson (TX Bar No. 24083263)
1000 Main Street, 36th Floor
Houston, Texas 77002-2764
Telephone: (713) 226-6000
Facsimile: (713) 226-6248
eenglish@porterhedges.com
sjohnson@porterhedges.com

OKIN ADAMS LLP

Matthew S. Okin (Texas Bar No. 00784695)
David L. Curry, Jr. (Texas Bar No. 24065107)
Edward A. Clarkson, III (Texas Bar No.
24059118)
mokin@okinadams.com
dcurry@okinadams.com
eclarkson@okinadams.com
1113 Vine Street, Suite 240
Houston, Texas 77002
Tel: (713) 228-4100
Fax: (346) 247-7158

Counsel to L Bond Management, LLC

AKIN GUMP STRAUSS HAUER & FELD LLP

Lacy M. Lawrence
State Bar No. 24055913; S.D. Tex. No. 995675
2300 N. Field St., Suite 1800
Dallas, TX 75201
Telephone: (214) 969-2800
Facsimile: (214) 969-4343
llawrence@akingump.com

-and-

Michael S. Stamer (admitted *pro hac vice*)
Abid Qureshi (admitted *pro hac vice*)
Jason P. Rubin (admitted *pro hac vice*)
One Bryant Park
New York, New York 10036
Telephone: (212) 872-1000
Facsimile: (212) 872-1002
mstamer@akingump.com
aquireshi@akingump.com
jrubin@akingump.com

-and-

Scott L. Alberino (admitted *pro hac vice*)
Benjamin L. Taylor (admitted *pro hac vice*)
Robert S. Strauss Tower
2001 K Street, N.W.
Washington, DC 20006-1037
Phone: (202) 887-4000
Fax: (202) 887-4288
salberino@akingump.com
taylorb@akingump.com

*Counsel to the Official Committee of Bondholders
of GWG Holdings, Inc., et al.*

Exhibit A

Modified Second Amended Plan

[separately filed]

IN THE UNITED STATES BANKRUPTCY COURT
FOR THE SOUTHERN DISTRICT OF TEXAS
HOUSTON DIVISION

In re:)
) Chapter 11
)
GWG Holdings, Inc., et al.,1)
) Case No. 22-90032 (MI)
)
Debtors.)
) (Jointly Administered)
)

DEBTORS' FURTHER MODIFIED SECOND AMENDED JOINT CHAPTER 11 PLAN,
SUBMITTED BY THE DEBTORS, THE BONDHOLDER COMMITTEE,
AND L BOND MANAGEMENT, LLC AS CO-PROONENTS

April 20, 2023

JACKSON WALKER LLP

Kristhy M. Peguero (TX Bar No. 24102776)
Matthew D. Cavenaugh (TX Bar No. 24062656)
1401 McKinney Street, Suite 1900
Houston, TX 77010
Telephone: (713) 752-4200
Email: kpeguero@jw.com
mcavenaugh@jw.com

Co-Counsel for the Debtors and Debtors in Possession

MAYER BROWN LLP

Charles S. Kelley (TX Bar No. 11199580)
700 Louisiana Street, Suite 3400
Houston, TX 77002-2730
Telephone: (713) 238-3000
Email: ckelley@mayerbrown.com

Thomas S. Kiriakos (admitted pro hac vice)
Louis S. Chiappetta (admitted pro hac vice)
Jamie R. Netznik (admitted pro hac vice)

Lisa Holl Chang

Joshua R. Gross (admitted pro hac vice)

Jade Edwards

71 S. Wacker Drive

Chicago, IL 60606

Telephone: (312) 782-0600

Email: tkiriakos@mayerbrown.com
lchiappetta@mayerbrown.com
jnetznik@mayerbrown.com
lhollchang@mayerbrown.com
jgross@mayerbrown.com
jmedwards@mayerbrown.com

Adam C. Paul (admitted pro hac vice)

Lucy F. Kweskin (admitted pro hac vice)

Ashley Anglade

1221 Avenue of the Americas

New York, NY 10020-1001

Telephone: (212) 506-2500

Email: apaul@mayerbrown.com
lkweskin@mayerbrown.com
aanglade@mayerbrown.com

Counsel for the Debtors and Debtors in Possession

1 The Debtors in these chapter 11 cases, along with the last four digits of each Debtor's federal tax identification number, are: GWG Holdings, Inc. (2607); GWG Life, LLC (6955); GWG Life USA, LLC (5538); GWG DLP Funding IV, LLC (2589); GWG DLP Funding VI, LLC (6955); and GWG DLP Funding Holdings VI, LLC (6955). The location of Debtor GWG Holdings, Inc.'s principal place of business and the Debtors' service address is 325 N. St. Paul Street, Suite 2650 Dallas, TX 75201. Further information regarding the Debtors and these chapter 11 cases is available at the website of the Debtors' claims and noticing agent: https://donlinrecano.com/gwg.

TABLE OF CONTENTS

	Page
ARTICLE I. DEFINED TERMS, RULES OF INTERPRETATION, COMPUTATION OF TIME, AND GOVERNING LAW	1
A. <i>Defined Terms.</i>	1
B. <i>Rules of Interpretation.</i>	22
C. <i>Computation of Time.</i>	22
D. <i>Governing Law.</i>	22
E. <i>Reference to Monetary Figures.</i>	23
F. <i>Controlling Document.</i>	23
G. <i>Proponents' Consent Right.</i>	23
 ARTICLE II. ADMINISTRATIVE CLAIMS, ACCRUED PROFESSIONAL FEE COMPENSATION CLAIMS, DIP CLAIMS, PRIORITY TAX CLAIMS, INDENTURE DIMINUTION CLAIMS, AND SUBSTANTIAL CONTRIBUTION CLAIMS	 24
A. <i>Administrative Claims.</i>	24
B. <i>Accrued Professional Compensation Claims.</i>	25
C. <i>Chapford DIP Facility Claims.</i>	27
D. <i>Vida DIP Claims.</i>	27
E. <i>DLP Secured Claims.</i>	27
F. <i>Indenture Diminution Claims.</i>	27
G. <i>Priority Tax Claims.</i>	27
H. <i>Allowed AHC Substantial Contribution Claim.</i>	28
I. <i>Substantial Contribution Compensation and Expenses.</i>	28
 ARTICLE III. CLASSIFICATION AND TREATMENT OF CLAIMS AND INTERESTS.....	 28
A. <i>Summary of Classification.</i>	28
B. <i>Treatment of Claims and Interests.</i>	29
C. <i>Special Provision Governing Unimpaired Claims.</i>	33
D. <i>Elimination of Vacant Classes.</i>	33
E. <i>Voting Classes; Presumed Acceptance by Non-Voting Classes.</i>	34
F. <i>Subordinated Claims.</i>	34
G. <i>Presumed Acceptance of Plan.</i>	34
H. <i>Presumed Rejection of Plan.</i>	34
I. <i>Acceptance by Impaired Classes of Claims.</i>	34
J. <i>Acceptance by Impaired Classes of Interests.</i>	34
K. <i>Confirmation Pursuant to Sections 1129(a)(10) and 1129(b) of the Bankruptcy Code.</i>	35
L. <i>Controversies Regarding Impairment.</i>	35
 ARTICLE IV. MEANS FOR IMPLEMENTATION OF THE PLAN	 35
A. <i>Wind Down Trust.</i>	35
B. <i>U.S. Federal Income Tax Treatment and Reporting.</i>	38
C. <i>General Settlement of Claims and Interests.</i>	40
D. <i>Wind Down Transactions.</i>	40
E. <i>Litigation Trust.</i>	41
F. <i>Sources of Plan Consideration.</i>	44
G. <i>Redemption of New WDT Interests.</i>	46
H. <i>Priority of Cash Distributions to Holders of New WDT Interests.</i>	47
I. <i>LBM Settlement.</i>	48
J. <i>Exemption from Registration Requirements.</i>	49
K. <i>Section 1146(a) Exemption.</i>	50
L. <i>Cancellation of Securities and Agreements.</i>	51
M. <i>Corporate Action.</i>	51

N.	<i>Dissolution and Board of Directors.</i>	52
O.	<i>Effectuating Documents; Further Transactions.</i>	53
P.	<i>Vesting of Assets.</i>	53
Q.	<i>Preservation of Causes of Action.</i>	53
R.	<i>Continuing Effectiveness of Final Orders.</i>	54
S.	<i>D&O Liability Insurance Policies.</i>	55
T.	<i>Payment of Certain Fees.</i>	55
U.	<i>Beneficient SPAC Transaction Consents.</i>	56
V.	<i>Termination of Any Continuing Business Relationship With Beneficient.</i>	56
W.	<i>Compensation for Messrs. Stein and Horton.</i>	57
ARTICLE V. TREATMENT OF EXECUTORY CONTRACTS AND UNEXPIRED LEASES		57
A.	<i>Assumption and Rejection of Executory Contracts and Unexpired Leases.</i>	57
B.	<i>Claims Based on Rejection of Executory Contracts or Unexpired Leases.</i>	58
C.	<i>Cure of Defaults for Assumed Executory Contracts and Unexpired Leases.</i>	58
D.	<i>Insurance Policies.</i>	59
E.	<i>Modifications, Amendments, Supplements, Restatements, or Other Agreements.</i>	59
F.	<i>Reservation of Rights.</i>	60
G.	<i>Non-occurrence of the Effective Date.</i>	60
ARTICLE VI. PROVISIONS GOVERNING DISTRIBUTIONS		60
A.	<i>Timing and Calculation of Amounts to Be Distributed.</i>	60
B.	<i>Distributing Parties.</i>	60
C.	<i>Delivery of Distributions Related to the Litigation Trust.</i>	61
D.	<i>Delivery of Distributions and Undeliverable or Unclaimed Distributions.</i>	62
E.	<i>Single Satisfaction of Claims and Interests.</i>	64
F.	<i>No Postpetition Interest On Claims.</i>	64
G.	<i>Compliance with Tax Requirements/Allocations.</i>	64
H.	<i>Setoffs.</i>	64
I.	<i>Allocation of Plan Distributions between Principal and Interest.</i>	65
J.	<i>Claims Paid or Payable by Third Parties.</i>	65
ARTICLE VII. PROCEDURES FOR RESOLVING CONTINGENT, UNLIQUIDATED, AND DISPUTED CLAIMS		66
A.	<i>Allowance of Claims.</i>	66
B.	<i>Claims Administration Responsibilities.</i>	66
C.	<i>Estimation of Claims.</i>	67
D.	<i>Adjustment to Claims or Interests without Objection.</i>	67
E.	<i>Disallowance of Claims and Interests.</i>	67
F.	<i>Disputed Claims Reserve.</i>	68
G.	<i>Amendments to Claims.</i>	69
H.	<i>No Distributions Pending Allowance.</i>	69
I.	<i>Distributions After Allowance.</i>	69
ARTICLE VIII. SETTLEMENT, RELEASE, INJUNCTION, AND RELATED PROVISIONS		69
A.	<i>Settlement, Compromise, and Release of Claims and Interests.</i>	69
B.	<i>Release of Liens.</i>	70
C.	<i>Releases by the Debtors.</i>	70
D.	<i>[RESERVED.]</i>	72
E.	<i>Exculpation.</i>	72
F.	<i>Protections Against Discriminatory Treatment after the Effective Date.</i>	73
G.	<i>Injunction.</i>	73
H.	<i>Recoupment.</i>	74
I.	<i>Subordination Rights.</i>	74
J.	<i>Ipsa Facto and Similar Provisions Ineffective.</i>	74
K.	<i>Reimbursement or Contribution.</i>	74

ARTICLE IX. CONDITIONS PRECEDENT TO CONFIRMATION AND THE EFFECTIVE DATE.....	75
A. <i>Conditions Precedent to the Effective Date.</i>	75
B. <i>Effect of Non-Occurrence of Conditions Precedent to Consummation.</i>	77
C. <i>Waiver of Conditions Precedent.</i>	77
ARTICLE X. MODIFICATION, REVOCATION, OR WITHDRAWAL OF THE PLAN.....	77
A. <i>Modification and Amendments.</i>	77
B. <i>Effect of Confirmation on Modifications.</i>	77
C. <i>Revocation or Withdrawal of the Plan.</i>	78
ARTICLE XI. RETENTION OF JURISDICTION	78
ARTICLE XII. MISCELLANEOUS PROVISIONS	80
A. <i>Immediate Binding Effect.</i>	80
B. <i>Additional Documents.</i>	81
C. <i>Payment of Statutory Fees.</i>	81
D. <i>Dissolution of the Bondholder Committee.</i>	81
E. <i>Reservation of Rights.</i>	81
F. <i>Successors and Assigns.</i>	82
G. <i>Service of Documents.</i>	82
H. <i>Enforcement of Confirmation Order.</i>	83
I. <i>Term of Injunctions or Stays.</i>	83
J. <i>Entire Agreement.</i>	83
K. <i>Votes Solicited in Good Faith.</i>	83
L. <i>Exhibits.</i>	84
M. <i>Nonseverability of Plan Provisions.</i>	84
N. <i>Closing of Chapter 11 Cases.</i>	84
O. <i>Creditor Default.</i>	84
P. <i>Waiver or Estoppel.</i>	84

INTRODUCTION

GWG Holdings, Inc. and its affiliated debtors and debtors in possession in the above-captioned chapter 11 cases propose the following joint plan pursuant to chapter 11 of title 11 of the United States Code. Capitalized terms used herein and not otherwise defined shall have the meanings ascribed to such terms in Article I.A hereof. Although proposed jointly for administrative purposes, this Plan constitutes a separate plan for each of the Debtors (as that term is defined herein) for the resolution of outstanding Claims and Interests pursuant to the Bankruptcy Code, and this Plan does not contemplate substantive consolidation of any of the Debtors. Each of the Debtors, the Bondholder Committee, and LBM is a proponent of this Plan within the meaning of section 1129 of the Bankruptcy Code.

The Plan is supported by the Bondholder Committee and LBM. The Plan, if consummated, will effectuate the terms of the Mediated Settlement (as reflected in the Mediation Agreement), which is further described in the Disclosure Statement.

Reference is made to the accompanying *Disclosure Statement for the Debtors' Further Modified Second Amended Joint Chapter 11 Plan* for a discussion of the Debtors' history, business, operations, valuation, projections, risk factors, a summary and analysis of this Plan and the transactions contemplated thereby, and certain related matters.

ALL HOLDERS OF CLAIMS AND INTERESTS, TO THE EXTENT APPLICABLE, ARE ENCOURAGED TO READ THIS PLAN AND THE DISCLOSURE STATEMENT IN THEIR ENTIRETY BEFORE VOTING TO ACCEPT OR REJECT THIS PLAN.

ARTICLE I. DEFINED TERMS, RULES OF INTERPRETATION, COMPUTATION OF TIME, AND GOVERNING LAW

A. *Defined Terms.*

As used in this Plan, capitalized terms have the meanings and effect as set forth below.

1. “1940 Act” means the U.S. Investment Company Act of 1940, as amended, 15 U.S.C. §§ 80a-1–80a-64, or any similar federal, state, or local law, as now in effect or hereafter amended, and the rules and regulations promulgated thereunder.

2. “2018 Supplemental Indenture” means that certain Supplemental Indenture, dated as of August 10, 2018, as amended, restated, amended and restated, supplemented, or otherwise modified from time to time, among Debtors GWGH and GWG Life and the Indenture Trustee, to add and modify certain provisions of the A&R Indenture necessary to provide for the issuance of the Seller Trust L Bonds.

3. “2020 Supplemental Indenture” means that certain Supplemental Indenture, dated as of December 31, 2020, as amended, restated, amended and restated, supplemented, or otherwise modified from time to time, among Debtors GWGH and GWG Life and the Indenture Trustee, to add and modify certain provisions of the A&R Indenture necessary to provide for the issuance of the Liquidity Bonds.

4. “A&R Indenture” means that certain Amended and Restated Indenture, dated as of October 23, 2017, as amended, restated, amended and restated, supplemented, or otherwise modified from time to time, among Debtors GWGH and GWG Life and the Indenture Trustee, providing for the issuance of the Public L Bonds, the Seller Trust L Bonds, and the Liquidity Bonds.

5. “Accrued Professional Compensation Claims” means, at any given moment, all Claims for accrued fees and expenses for services rendered by a Professional through and including the Confirmation Date, to the extent such fees and expenses have not been paid pursuant to the Interim Compensation Order or any other order of the Bankruptcy Court and regardless of whether a fee application has been Filed for such fees and expenses; *provided* that, to the extent the Bankruptcy Court denies or reduces by a Final Order any amount of a Professional’s requested fees or expenses, then the amount by which such fees or expenses are reduced or denied shall reduce the applicable Accrued Professional Compensation Claim and the Professional Fee Escrow Amount with respect to such Claim.

6. “Ad Hoc Broker/Dealer Committee” means an ad hoc committee of registered broker/dealers and registered investment advisors, which committee is represented by Proskauer Rose LLP.

7. “Administrative Claim” means a Claim for costs and expenses of the administration of the Estates pursuant to sections 503(b), 507(a)(2), 507(b), or 1114(e)(2) of the Bankruptcy Code, including: (a) the actual and necessary costs and expenses of preserving the Estates and operating the business of the Debtors incurred after the applicable Petition Date and through the Effective Date; (b) Accrued Professional Compensation Claims; (c) the Independent Director Fee Claims; (d) fees and charges assessed against the Estates pursuant to chapter 123 of the Judicial Code, including the fees of the U.S. Trustee payable pursuant to section 1930(a) of the Judicial Code; (e) the Indenture Diminution Claims; and (f) the Allowed AHC Substantial Contribution Claim.

8. “Administrative Claims Payment Date” means, with respect to an Administrative Claim, the earlier of: (a) the Effective Date; (b) if the Administrative Claim is not Allowed as of the Effective Date, as soon as reasonably practicable after the date on which an order Allowing such Administrative Claim becomes a Final Order; and (c) if the Allowed Administrative Claim is based on liabilities incurred by the Debtors in the ordinary course of their business after the applicable Petition Date, pursuant to the terms and conditions of the particular transaction giving rise to such Allowed Administrative Claims, without any further action by the Holders of such Allowed Administrative Claims and without any further notice to or action, order, or approval of the Bankruptcy Court.

9. “Affiliate” has the meaning set forth in section 101(2) of the Bankruptcy Code.

10. “Allowed” means with reference to any Claim or Interest, as applicable: (a) any Claim (i) for which a Proof of Claim or Proof of Interest has been timely Filed on or before the applicable Claims Bar Date (or for which a Proof of Claim or Proof of Interest is not required to be Filed pursuant to the Bankruptcy Code or a Final Order), or (ii) that is identified in the Schedules as of the Effective Date as not disputed, not contingent, and not unliquidated, and for which no

Proof of Claim or Proof of Interest has been timely Filed; *provided*, that, in each case, any such Claim shall be considered Allowed only if and to the extent that no objection or other challenge to the allowance thereof has been timely Filed prior to the Claim Objection Bar Date or such objection or challenge has been timely Filed and the Claim thereafter has been Allowed by a Final Order; or (b) any Claim expressly deemed allowed by the Plan (except as addressed in Article IV.I hereof) or allowed by a Final Order of the Bankruptcy Court (including pursuant to any stipulation or settlement agreement approved by the Bankruptcy Court). Claims allowed solely for the purpose of voting to accept or reject the Plan pursuant to an order of the Bankruptcy Court shall not be considered Allowed Claims unless otherwise subsequently Allowed. Any Claim that has been or is hereafter listed in the Schedules as contingent, unliquidated, or disputed, and for which no contrary or superseding Proof of Claim is or has been timely Filed, or that is not or has not been Allowed by a Final Order, is not considered Allowed and shall be expunged without further action by the Debtors and without further notice to any party or action, approval, or order of the Bankruptcy Court. Notwithstanding anything to the contrary herein, no Claim of any Entity subject to section 502(d) of the Bankruptcy Code shall be deemed Allowed unless and until such Entity pays in full the amount that it owes the applicable Debtor or Wind Down Debtor, as applicable. For the avoidance of doubt, a Proof of Claim Filed after the applicable Claims Bar Date shall not be Allowed for any purposes whatsoever absent entry of a Final Order Allowing such late-Filed Claim. “Allow” and “Allowing” shall have correlative meanings.

11. “Allowed AHC Substantial Contribution Claim” means the Administrative Claim of the Ad Hoc Broker/Dealer Committee, which shall be Allowed upon entry of the Confirmation Order, for the actual and reasonable fees and expenses of the Ad Hoc Broker/Dealer Committee which shall be payable on the Effective Date as set forth in Article II.H hereof.

12. “Allowed Bondholder Claims” means: (a) with respect to Direct-Held Bonds (as defined in the Bondholder Claim Procedures Order), (i) to the extent a timely Bondholder POC Form has been Filed pursuant to the Bondholder Claim Procedures Order, Bondholder Claims shall be Allowed in the amount set forth in any such Bondholder POC Form, provided, that, in each case, any such Bondholder Claim shall be considered Allowed only if and to the extent that no objection or other challenge to the allowance thereof has been timely Filed prior to the Claim Objection Bar Date or such an objection or other challenge has been Filed and the Bondholder Claim thereafter has been Allowed by a Final Order, or (ii) to the extent that no Bondholder POC Form has been timely Filed, Bondholder Claims shall be Allowed in the amounts set forth in the Holder Notices pursuant to the Bondholder Claim Procedures Order; (b) with respect to Indirect-Held Bonds (as defined in the Bondholder Claim Procedures Order), Bondholder Claims Allowed pursuant to the Bondholder Claim Procedures Order; and (c) the LBM L Bond Claims otherwise Allowed to the extent provided by Article IV.I hereof (which, for the avoidance of doubt, do not include the LBM Subordinated Claims).

13. “Assets” means all of the Debtors’ property, rights, and interests that are property of the Estates pursuant to section 541 of the Bankruptcy Code.

14. “Avoidance Actions” means any and all actual or potential claims and causes of action to avoid, recover, or subordinate a transfer of property or an obligation incurred by the Debtors that may be brought by or on behalf of the Debtors or their Estates pursuant to any applicable section of the Bankruptcy Code, including sections 502, 510, 542, 544, 545, 547-553,

and 724(a) of the Bankruptcy Code or under similar or related state, federal, or foreign statutes and common law, including fraudulent transfer laws or other applicable law.

15. “Bankruptcy Code” means title 11 of the United States Code, 11 U.S.C. §§ 101-1532, as amended.

16. “Bankruptcy Court” means the United States Bankruptcy Court for the Southern District of Texas, Houston Division, having jurisdiction over the Chapter 11 Cases and, to the extent of the withdrawal of any reference under 28 U.S.C. § 157, pursuant to section 151 of the Judicial Code, the United States District Court for the Southern District of Texas.

17. “Bankruptcy Local Rules” means the Bankruptcy Local Rules for the Southern District of Texas.

18. “Bankruptcy Rules” means the Federal Rules of Bankruptcy Procedure promulgated under section 2075 of the Judicial Code and the chambers rules of the Bankruptcy Court.

19. “Beneficient” means The Beneficient Company Group, L.P. and its subsidiaries.

20. “Bond Claims” means, collectively: (a) the Allowed Bondholder Claims; (b) any Indenture Fee and Expense Claims; and (c) subject to Article IV.I hereof, the LBM Subordinated Claims.

21. “Bondholder Claims” means any Claims for principal or interest evidenced by, arising under, or in connection with the Indenture (other than the LBM Subordinated Claims).

22. “Bondholder POC Forms” shall have the meaning set forth in the Bondholder Claim Procedures Order.

23. “Bondholder Claim Procedures Order” means the order entered by the Bankruptcy Court on August 29, 2022 [Dkt. No. 739].

24. “Bondholder Committee” means the official committee of bondholders appointed by the U.S. Trustee in the Chapter 11 Cases on May 9, 2022 [Dkt. No. 214].

25. “Broker Dealer(s)” means the registered broker/dealers and registered investment advisers that the Public L Bonds were offered and sold through.

26. “Business Day” means any day, other than a Saturday, Sunday, or “legal holiday” (as defined in Bankruptcy Rule 9006(a)).

27. “Cash” means the legal tender of the United States or the equivalent thereof.

28. “Causes of Action” means any claim, cause of action (including Avoidance Actions), controversy, right of setoff, cross-claim, counterclaim, or recoupment and any claim on contracts or for breaches of duties imposed by law or in equity, demand, right, action, Lien, indemnity, guaranty, suit, obligation, liability, damage, judgment, account, defense, power,

privilege, license, and franchise of any kind or character whatsoever, known, unknown, fixed or contingent, matured or unmatured, suspected or unsuspected, liquidated or unliquidated, disputed or undisputed, Secured or unsecured, assertable directly or derivatively, whether arising before, on, or after the applicable Petition Date, in contract or in tort, in law or in equity, or pursuant to any other theory of law.

29. “Certificate” means any instrument evidencing a Claim or Interest.

30. “Chapford DIP Facility” means the “Final DIP Facility,” as defined in the Chapford Final DIP Order.

31. “Chapford DIP Facility Claims” means any and all Claims for principal, interest, fees, costs, expenses, disbursements, and any and all other obligations of any kind under the Chapford DIP Facility, including any “DIP Obligations” (as defined in the Chapford Final DIP Order) owing as of the Effective Date; provided that, for the avoidance of doubt, the Chapford DIP Facility Claims shall not include the purported Alternate Stalking Horse Fee (as defined in the Chapford Final DIP Order).

32. “Chapford Final DIP Order” means the *Final Order (I) Authorizing the Debtors to Obtain Postpetition Financing, (II) Authorizing the Debtors to Use Cash Collateral, (III) Granting Liens and Providing Claims* [Dkt. No. 606].

33. “Chapter 11 Cases” means the jointly-administered chapter 11 cases of the Debtors pending before the Bankruptcy Court under the lead case of GWG Holdings, Inc., *et al.*, No. 22-90032 (MI) (Bankr. S.D. Tex.).

34. “Claim” means any “claim” (as defined in section 101(5) of the Bankruptcy Code).

35. “Claims Bar Date” means the applicable bar date by which a Proof of Claim or Proof of Interest, or request for payment of administrative expenses must be, or must have been, Filed, as established by an order of the Bankruptcy Court, including the Confirmation Order.

36. “Claims Objection Bar Date” shall mean, subject to rule 9006 of the Federal Rules of Bankruptcy Procedure, the date that is 180 days following the Effective Date.

37. “Claims Register” means the official register of Claims maintained by the Clerk of the Bankruptcy Court or the Notice and Solicitation Agent.

38. “Class” means a category of Holders of Claims or Interests as set forth in Article III of the Plan in accordance with section 1122(a) of the Bankruptcy Code.

39. “Compensation Motion” means the *Debtors’ Motion for Entry of an Order Approving Amendments to Consulting Agreement With Jeffrey S. Stein and Independent Director Agreement With Anthony R. Horton and Granting Related Relief* [Dkt. No. 1392].

40. “Confirmation” means the entry of a Confirmation Order on the docket of the Chapter 11 Cases.

41. “Confirmation Date” means the date upon which the Bankruptcy Court enters the Confirmation Order on the docket of the Chapter 11 Cases within the meaning of Bankruptcy Rules 5003 and 9021.

42. “Confirmation Hearing” means the hearing held by the Bankruptcy Court to consider entry of a Confirmation Order pursuant to section 1129 of the Bankruptcy Code.

43. “Confirmation Order” means a Final Order of the Bankruptcy Court confirming the Plan pursuant to section 1129 of the Bankruptcy Code, the form and substance of which being subject to the Proponents’ Consent Right.

44. “Consummation” means the occurrence of the Effective Date for the Plan.

45. “Creditor Proponents” means the Bondholder Committee and LBM.

46. “CRO/ID Order” means the *Order Authorizing and Approving (I) Designation of Jeffrey S. Stein as Chief Restructuring Officer, (II) the Appointment of Jeffrey S. Stein and Anthony R. Horton as New Independent Directors, and (III) Granting Related Relief* [Dkt. No. 594].

47. “Cure Amounts” means all amounts (or such other amount as may be agreed upon by the parties under an Executory Contract or Unexpired Lease) required to cure any monetary defaults and other obligations required to cure any non-monetary defaults (the performance required to cure such non-monetary defaults and the timing of such performance will be described in reasonable detail in a notice of proposed assumption and assignment) under any Executory Contract or Unexpired Lease that is to be assumed or assumed and assigned by the Debtors pursuant to sections 365 or 1123 of the Bankruptcy Code.

48. “D&O Insurance Order” has the meaning set forth in Article II.B.1 hereof.

49. “D&O Liability Insurance Policies” means all insurance policies (including, without limitation, directors and officers liability policy, management liability policy, professional liability policy, general liability policy, errors and omissions policy, excess policy, umbrella policy, and/or any “tail policy”) for current or former directors, members, trustees, officers, and managers’ liability maintained by the Debtors as of the Effective Date.

50. “Debtors” means, collectively, GWG Holdings, Inc., GWG Life, LLC, GWG Life USA, LLC, GWG DLP Funding IV, LLC, GWG DLP Funding VI, LLC, and GWG DLP Funding Holdings VI, LLC.

51. “Debtor Release” means the releases set forth in Article VIII.C of this Plan.

52. “Direct Holder Notices” shall have the meaning set forth in the Bondholder Claim Procedures Order.

53. “Disclosure Statement” means the disclosure statement (including all exhibits and schedules thereto or referenced therein), as may be amended, supplemented, or modified from time to time, that relates to this Plan and has been prepared and distributed by the Debtors, the

Bondholder Committee, and LBM as joint plan proponents in accordance with the Bankruptcy Code, the Bankruptcy Rules, and any other applicable law.

54. “Disputed” means, with respect to any Claim or Interest or any portion thereof: (a) any Claim or Interest that is not Allowed; (b) any Claim or Interest that is not disallowed under the Plan, the Bankruptcy Code, or a Final Order, as applicable; and (c) any Claim or Interest to which any party in interest has interposed a timely objection or request for estimation, and such objection or request for estimation has not been withdrawn or determined by a Final Order. For the avoidance of doubt, a Disputed Claim or Interest shall not include any Claim or Interest that has been deemed Allowed under the Plan (except as otherwise addressed in Article IV.I hereof) or by Final Order.

55. “Disputed Claims Reserve” means a reserve in an amount equal to the Disputed Claims Reserve Amount for distributions on account of Disputed Claims that are subsequently Allowed after the Effective Date. To the extent that any Claim is Disputed, and where this Plan provides for the payment in Cash on the Effective Date of such Claim if such Claim were Allowed, on the Effective Date, the Debtors shall transfer the pro rata portion of such Claim’s distribution under the Plan to the Disputed Claims Reserve, where such amount shall be held in trust for the benefit of such Holder pending resolution by a Final Order or as otherwise agreed between the Wind Down Debtors on one hand, and such Holder on the other hand. The Wind Down Trust shall have a reversionary interest, which shall be distributed in accordance with Article III and Article IV.H of this Plan, in the excess, if any, of any Cash or other property held in the Disputed Claims Reserve on account of any Disputed Claim after such Disputed Claim or portion thereof ultimately is disallowed by a Final Order or otherwise resolved between the Holder of the Disputed Claim and the Wind Down Debtors in a manner that leaves an excess amount in the Disputed Claims Reserve.

56. “Disputed Claims Reserve Amount” means the amount of assets determined prior to the Effective Date by the Debtors, in consultation with the Creditor Proponents, that would likely have been distributed to the Holders of all applicable Disputed Claims against the Debtors as if such Disputed Claims against the Debtors had been Allowed Claims against the Debtors on the Effective Date, with the amount of such Allowed Claims to be determined, solely for the purposes of establishing reserves and for maximum distribution purposes, to be: (a) the lesser of (i) the asserted amount of each Disputed Claim against the Debtors as scheduled by the Debtors or, if and solely to the extent a non-duplicative Proof of Claim was Filed in an asserted amount greater than the scheduled amount, the asserted amount Filed with the Bankruptcy Court as set forth in such non-duplicative Proof of Claim or as provided by the parties to the Debtors as further information with respect to the Proof of Claim, and (ii) the amount, if any, estimated by the Bankruptcy Court pursuant to section 502(c) of the Bankruptcy Code or ordered by other order of the Bankruptcy Court; or (b) the amount otherwise agreed to by the Debtors and the Holder of such Disputed or unliquidated Claim for reserve purposes.

57. “Distribution Record Date” means, other than with respect to publicly-held securities, the record date for purposes of making distributions under the Plan on account of Allowed Claims and Allowed Interests, which date shall be the later of the first day of the Confirmation Hearing or the day that such Claim becomes an Allowed Claim.

58. “DLP Entities” means Debtors DLP IV, DLP VI, and GWG DLP Funding Holdings VI, LLC.

59. “DLP Entity General Unsecured Claims” mean any Claim against any of the DLP Entities that is not Secured and that is not: (a) an Administrative Claim; (b) Chapford DIP Facility Claim; (c) Vida DIP Claim; (d) DLP Secured Claim; (e) Priority Tax Claim; (f) Other Secured Claim; (g) Other Priority Claim; (h) Bond Claim; or (i) Intercompany Claim.

60. “DLP Independent Directors” means Albert J. Fioravanti and Sean Clements.

61. “DLP IV” means Debtor GWG DLP Funding IV, LLC.

62. “DLP IV Agent” means CLMG Corp., in its capacity as the administrative agent under the DLP IV Credit Agreement.

63. “DLP IV Credit Agreement” means that certain Fifth Amended and Restated Loan and Security Agreement (as may be amended, restated, amended and restated, supplemented, or otherwise modified from time to time), dated December 14, 2021, by and between Debtor DLP IV as borrower, DLP IV Agent as administrative agent, and the DLP IV Lenders as lenders thereto.

64. “DLP IV Lenders” means the lenders from time to time party to the DLP IV Credit Agreement.

65. “DLP IV Secured Claims” means any Claims evidenced by, arising under, or in connection with the DLP IV Credit Agreement or other agreements related thereto.

66. “DLP Secured Claims” means, collectively, the DLP IV Secured Claims and the DLP VI Secured Claims.

67. “DLP VI” means Debtor GWG DLP Funding VI, LLC.

68. “DLP VI Agent” means National Founders LP, in its capacity as the administrative agent under the DLP VI Credit Agreement.

69. “DLP VI Credit Agreement” means that certain Credit Agreement (as may be amended, restated, amended and restated, supplemented, or otherwise modified from time to time), dated August 11, 2021, by and among the Debtor DLP VI as borrower, DLP VI Agent as administrative agent, and DLP VI Lender as the sole lender.

70. “DLP VI Lender” means National Founders LP, in its capacity as the sole lender under the DLP VI Credit Agreement.

71. “DLP VI Secured Claims” means any Claims evidenced by, arising under, or in connection with the DLP VI Credit Agreement or other agreements related thereto.

72. “DTC” means The Depository Trust Company.

73. “Effective Date” means, with respect to the Plan, the date that is a Business Day selected by the Debtors, in consultation with the Creditor Proponents, on or after the Confirmation Date on which: (a) no stay of the Confirmation Order is in effect; (b) all conditions precedent specified in Article IX.A of this Plan have been satisfied or waived (in accordance with Article IX.C of this Plan); and (c) the Debtors declare that the Plan is effective.

74. “Entity” shall have the meaning set forth in section 101(15) of the Bankruptcy Code.

75. “Estate” means, as to each Debtor, the estate created for the Debtor pursuant to section 541 of the Bankruptcy Code upon the commencement of the applicable Debtor’s Chapter 11 Case.

76. “Estimated Effective Date Shortfall Amount” means the amount, if any, that the Debtors, in consultation with the Creditor Proponents, estimate prior to the Effective Date to be the difference between: (a) all Allowed Claims required to be paid or provided for in full, in Cash on the Effective Date under the provisions of this Plan; and (b) the amount of Cash that the Debtors expect to have available for such purpose on the Effective Date that does not consist of any of the net Cash proceeds of the Vida DIP Financing Facility.

77. “Exculpated Claim” means any claim related to any act or omission from the Petition Date to the Effective Date in connection with, relating to, or arising out of: (a) the Chapter 11 Cases; (b) the formulation, preparation, dissemination, or negotiation of any document in connection with the Chapter 11 Cases; (c) any contract, instrument, release, and/or other agreement or document created or entered into in connection with the Chapter 11 Cases; (d) the pursuit of Consummation; and/or (e) the Filing, administration, and/or implementation of the Chapter 11 Cases, or the distribution of property in connection therewith or thereunder; *provided*, that, for the avoidance of doubt, any prepetition advice provided by any legal professionals in connection with prepetition transactions between the Debtors and Beneficient shall not constitute any act or omission that is covered by this definition of Exculpated Claim; *provided, further*, that, notwithstanding the foregoing, Exculpated Claims shall not include anything related to any act or omission that is determined in a Final Order to have constituted actual fraud, willful misconduct, intentional breach of fiduciary duty, or gross negligence.

78. “Exculpated Party” means, collectively, and in each case, in their respective capacities as such: (a) Jeffrey S. Stein, in his capacities as an officer, an Independent Director, and a director of the Debtors; (b) Anthony R. Horton, in his capacities as an Independent Director and director of the Debtors; (c) Michael A. Tucker, in his capacity as an officer of the Debtors; (d) the Non-Management Directors, in their capacity as such; (e) the DLP Independent Directors, in their capacity as such; (f) the members of the Bondholder Committee, in their capacity as such; (g) any Professional retained by the Debtors, the Independent Directors, the DLP Independent Directors, the Bondholder Committee, in such Professionals’ capacity as such; and (h) any professional retained by any of the members of the Bondholder Committee, each in such professionals’ capacity as such.

79. “Executory Contract” means a contract to which a Debtor is a party that is subject to assumption, assumption and assignment, or rejection under sections 365 or 1123 of the Bankruptcy Code.

80. “Existing Common Interests” means the Interests in Debtor GWGH arising from or related to the Existing Common Stock.

81. “Existing Common Stock” means the shares of common stock issued by Debtor GWGH.

82. “Federal Judgment Rate” means the federal judgment rate in effect as of the Effective Date.

83. “File,” “Filed,” or “Filing” means file, filed, or filing in the Chapter 11 Cases with the Bankruptcy Court or, with respect to the filing of a Proof of Claim or Proof of Interest, the Notice and Solicitation Agent.

84. “Final Vida Order” means the *Final Order (A) Authorizing the Debtors to Obtain Replacement DIP Financing From Vida Insurance Credit Opportunity Fund III GP, LLC and Its Affiliates and Enter Into and Perform Under the Replacement DIP Credit Documents, (B) Authorizing the Debtors to Use Cash Collateral, (C) Granting Liens and Providing Claims with Superpriority Administrative Expense Status, (D) Authorizing the Refinancing of Prepetition and Postpetition Secured Debt, (E) Authorizing Amending the Option Agreement, (F) Modifying the Automatic Stay, and (G) Granting Related Relief* [Dkt. No. 1144].

85. “Final Order” means, as applicable, an order or judgment of the Bankruptcy Court or other court of competent means, as applicable, an order or judgment of the Bankruptcy Court or other court of competent jurisdiction with respect to the relevant subject matter, which has not been reversed, stayed, modified, or amended, and as to which the time to appeal or seek certiorari has expired and no appeal or petition for certiorari has been timely taken, or as to which any appeal that has been taken or any petition for certiorari that has been or may be Filed has been resolved by the highest court to which the order or judgment was appealed or from which certiorari was sought or the new trial, reargument, or rehearing shall have been denied, resulted in no stay pending appeal of such order, or has otherwise been dismissed with prejudice; *provided* that the possibility that a motion under rule 60 of the Federal Rules of Civil Procedure, or any analogous rule under the Bankruptcy Rules or the Bankruptcy Local Rules, may be Filed relating to such order shall not prevent such order from being a Final Order.

86. “FOXO” means FOXO Technologies, Inc.

87. “General Unsecured Claim” means any Claim that is not Secured and that is not: (a) an Administrative Claim; (b) a Chapford DIP Facility Claim; (c) a Vida DIP Claim; (d) a DLP Secured Claim; (e) a Priority Tax Claim; (f) an Other Secured Claim; (g) an Other Priority Claim; (h) a Bond Claim; (i) a DLP Entity General Unsecured Claim; or (j) an Intercompany Claim; *provided*, that, for the avoidance of doubt, a Claim in the amount of \$2,750.00 or less that would otherwise be a General Unsecured Claim shall be treated as a GUC Convenience Claim for purposes of this Plan.

88. “Governmental Unit” shall have the meaning set forth in section 101(27) of the Bankruptcy Code.

89. “GUC Convenience Claim” means an Allowed Claim in an amount greater than \$0.01 but less than or equal to \$2,750.00, that would otherwise qualify as a General Unsecured Claim; *provided*, that any Holder of an Allowed General Unsecured Claim may elect to have such Claim reduced to \$2,750.00 and treated as an Allowed GUC Convenience Claim for purposes of this Plan; *provided, further*, that, notwithstanding the foregoing, the total GUC Convenience Claims shall not exceed \$150,000 in the aggregate.

90. “GWGH” means Debtor GWG Holdings, Inc.

91. “GWG Life” means Debtor GWG Life, LLC.

92. “Holder” means any Entity holding a Claim or an Interest.

93. “Holder Notices” means the Indirect Holder Notices and Direct Holder Notices distributed by the Notice and Solicitation Agent at the direction of the Debtors pursuant to the Bondholder Claim Procedures Order.

94. “Impaired” means, with respect to a Class of Claims or Interests, a Class of Claims or Interests that is impaired within the meaning of section 1124 of the Bankruptcy Code.

95. “Indenture” means, collectively, the A&R Indenture, the 2018 Supplemental Indenture, and the 2020 Supplemental Indenture.

96. “Indenture Diminution Claims” means any Claims of the Indenture Trustee asserted on account of the decrease in value of the Indenture Trustee’s interest in the collateral securing the obligations under the Indenture, arising from the “Adequate Protection Liens” granted to the Indenture Trustee pursuant to the Chapford Final DIP Order and the Final Vida Order. On the Effective Date, the Indenture Diminution Claims shall be deemed an Allowed Administrative Claim in the amount as agreed by the Debtors, the Indenture Trustee, and the Creditor Proponents, or as determined by the Court, in the event such parties are unable to reach an agreement as to the amount during further mediation.

97. “Indenture Documents” means the Indenture, the Public L Bonds, the Seller Trust L Bonds, and the Liquidity Bonds, and any amendments, modifications, or supplements thereto, and any notes, certificates, agreements, security agreements, documents, and instruments related thereto or executed in connection therewith.

98. “Indenture Fee and Expense Claims” means any Claims of the Indenture Trustee payable pursuant to Article IV.T hereof, Article IV.L hereof, or the Indenture Documents, for its reasonable and documented fees and expenses and for indemnity, subrogation, and contribution, including, without limitation, attorneys’ fees and expenses, arising under or in connection with the Indenture Documents, including in its capacity as collateral agent thereunder, whether before or after April 20, 2022 or before or after the Effective Date; *provided*, that, after the Effective Date, the Indenture Trustee shall not be able to assert any Claim against the Debtors or the Wind Down Debtors (except as otherwise provided in this Plan).

99. “Indenture Trustee” means Bank of Utah, in its capacity as the Indenture Trustee under the Indenture.

100. “Indenture Trustee Charging Lien” means any Lien or other priority of payment to which the Indenture Trustee is entitled under the Indenture Documents, against distributions to be made to Holders of Claims under the Indenture Documents, for payment of any Indenture Fee and Expense Claims. For the avoidance of doubt, nothing contained in this Plan is intended to create or expand any such Lien (including its priority) beyond what is provided under the Indenture Documents and authorized and/or enforceable under applicable law.

101. “Independent Director Fee Claims” means all unpaid fees and expenses as of the Effective Date due to the Independent Directors, the DLP Independent Directors, or David F. Chavenson pursuant to their respective agreements with the Debtors, as authorized by the CRO/ID Order or otherwise. On the Effective Date, the Independent Director Fee Claims shall be deemed Allowed Administrative Claims.

102. “Independent Directors” means Jeffrey S. Stein and Anthony R. Horton.

103. “Indirect Holder Notices” shall have the meaning set forth in the Bondholder Claim Procedures Order.

104. “Initial Litigation Trust Assets” means the following assets, which will ultimately vest in the Litigation Trust free and clear of all liens, claims, interests, and encumbrances on the Effective Date: (a) the Initial Litigation Trust Funding Amount; (b) the Retained Causes of Action; (c) the Debtors’ interests in the D&O Liability Insurance Policies that provide coverage prior to April 20, 2022; and (d) the Debtors’ interests in the proceeds of such policies and the Debtors’ entitlements and rights to payments thereunder.

105. “Initial Litigation Trust Funding Amount” means an amount equal to \$3 million in Cash.

106. “Intercompany Claim” means any Claim against a Debtor held by another Debtor.

107. “Intercompany Interest” means any Interest in one Debtor held by another Debtor.

108. “Interest” means any equity security (as defined in section 101(16) of the Bankruptcy Code) in any Debtor outstanding immediately prior to the applicable Petition Date, including any options, warrants, or other rights with respect thereto, or any other instruments evidencing an ownership interest in any of the Debtors and the rights of any Entity to purchase or demand the issuance of any of the foregoing, including: (a) redemption, conversion, exchange, voting, participation, and dividend rights (including any rights in respect of accrued and unpaid dividends); (b) liquidating preferences; and (c) stock options and warrants.

109. “Interim Compensation Order” means the *Corrected Order (I) Establishing Procedures for Interim Compensation and Reimbursement of Expenses for Professionals and (II) Granting Related Relief* [Dkt. No. 378].

110. “Investigations Committee” means the Investigations Committee formed pursuant to the Resolutions of the Board of Directors of GWGH, dated June 19, 2022 (as subsequently amended and restated on July 13, 2022 and July 17, 2022).

111. “Judicial Code” means title 28 of the United States Code, 28 U.S.C. §§ 1-4001.

112. “LBM” means L Bond Management, LLC.

113. “LBM L Bond Claims” shall mean all amounts owed by the Debtors on Claims held by the following trusts for principal or interest evidenced by, arising under, or in connection with the Indenture as of April 20, 2022: The LT-1 Exchange Trust (c/o MHT Financial LLC), The LT-2 Exchange Trust, The LT-3 Exchange Trust, The LT-4 Exchange Trust, The LT-5 Exchange Trust, The LT-6 Exchange Trust, The LT-7 Exchange Trust, The LT-8 Exchange Trust, The LT-9 Exchange Trust, The LT-12 Exchange Trust, The LT-14 Exchange Trust, The LT-15 Exchange Trust, The LT-16 Exchange Trust, The LT-17 Exchange Trust, The LT-18 Exchange Trust, The LT-19 Exchange Trust, The LT-20 Exchange Trust, The LT-21A Custody Trust, The LT-22A Custody Trust, The LT-23A Custody Trust, The LT-24A Custody Trust, The LT-25A Custody Trust, and The LT-26A Custody Trust. For the avoidance of doubt (and except as provided in Article IV.I hereof), LBM L Bond Claims, including the LBM Subordinated Claims, are deemed Allowed under this Plan, shall be Allowed upon entry of the Confirmation Order, and otherwise constitute Allowed Class 3 Bond Claims.

114. “LBM Released Claims” means any and all civil claims held by the Debtors’ Estates against the LBM Released Parties.

115. “LBM Released Parties” means, collectively, and in each case in their respective capacities as such: (a) LBM; (b) LBM’s managers, employees, agents, attorneys and representatives solely in such capacity and solely for actions taken in such capacity that are related to the acquisition, holding, or disposition of any Seller Trust L Bonds for which LBM acts as agent including the LBM L Bond Claims; (c) the trusts identified in the definition of LBM L Bond Claims, the trustees and trust advisors of such trusts, current officers, directors, and advisors of such trusts, each solely in such capacity and solely for actions taken on behalf of such trusts; and (d) Richard Schmidt and his professionals; *provided, however*, that any release of the LBM Released Claims are to be narrowly construed, and to the extent any LBM Released Parties serve or have served in multiple capacities, such releases do not extend beyond capacities as described above.

116. “LBM Settlement” means the agreement between the Debtors and the Creditor Proponents set forth in Article IV.I hereof.

117. “LBM Subordinated Claims” means, as applicable: (a) where LBM has not timely withdrawn from the settlement described in Article IV.I of this Plan, the portion of the Allowed LBM L Bond Claims equal to fifteen percent (15%) of the total amount of such Claims as of April 20, 2022; or (b) where LBM has timely withdrawn from such settlement, the portion of such Bond Claims, if any, subordinated pursuant to a Final Order of the Bankruptcy Court.

118. “Lien” shall have the meaning set forth in section 101(37) of the Bankruptcy Code.

119. “Litigation Trust” means the litigation trust established on the Effective Date for the purpose of prosecuting or settling the Retained Causes of Action through the distribution of net proceeds thereof to the Wind Down Trust.

120. “Litigation Trust Agreement” means the agreement governing the Litigation Trust, the form and substance of which being subject to the Proponents’ Consent Right, which shall be Filed as part of the Plan Supplement.

121. “Litigation Trust Reconciliation Claims” means Claims or Interests held or Filed by any: (a) defendant in any litigation initiated by the Litigation Trustee or, in consultation with the Wind Down Trustee, Entity against whom the Litigation Trustee expects to initiate litigation; (b) any Broker Dealers; and (c) Holders of LBM L Bond Claims, in the event LBM withdraws from the settlement described in Article IV.I herein.

122. “Litigation Trustee” means Michael I. Goldberg, or such other independent, third-party fiduciary appointed as trustee of the Litigation Trust by the Bondholder Committee in their sole discretion and as identified in the Plan Supplement; *provided*, that, for the avoidance of doubt, the Litigation Trustee shall have no affiliation with any Bondholder Committee member and must not own any Public L Bonds, New WDT Interests, or other Interests in or Securities issued by any of the Debtors. The Litigation Trustee shall, among other things: (a) prosecute and/or settle the Retained Causes of Action; and (b) facilitate distributions as set forth in Section IV.D hereof.

123. “Liquidating Company Exception” has the meaning set forth in Article IV.A.5 of this Plan.

124. “Liquidity Bonds” means the bonds issued pursuant to and under the 2020 Supplemental Indenture.

125. “Minimum Distribution Amount” means \$15,000,000 in Cash.

126. “Mediated Settlement” means the settlement by and among the Debtors and the Creditor Proponents, memorialized in the Mediation Agreement.

127. “Mediation Agreement” means the written agreement entered into by the Debtors and the Creditor Proponents, dated as of March 9, 2023 [Dkt. No. 1518], which is described in further detail in the Disclosure Statement.

128. “Net Cash Proceeds” means with respect to any disposition or monetization by the Wind Down Trustee of any of the Wind Down Trust Assets, including of any interest in Beneficiary or FOXO, the excess, if any, of: (a) the sum of cash and cash equivalents received in connection with such transaction (including any cash or cash equivalents received by way of deferred payment pursuant to, or by monetization of, a note receivable or otherwise, but only as and when so received); less (b) the sum of (i) the reasonable and customary out-of-pocket expenses incurred by the Wind Down Trustee, as applicable, in connection with such transaction and (ii) income taxes reasonably estimated to be actually payable within two years of the date of the relevant transaction as a result of any gain recognized in connection therewith; *provided* that, if the amount of any estimated taxes pursuant to subclause (ii) exceeds the amount of taxes actually

required to be paid in cash in respect of such disposition or monetization, the aggregate amount of such excess shall constitute Net Cash Proceeds.

129. “New Series A1 WDT Interests” shall mean the new beneficial interests in the Wind Down Trust issued to Holders of Allowed Bond Claims in Class 3 (other than Allowed LBM Subordinated Claims) pursuant to this Plan in an amount equal to the amount of the outstanding Allowed Bond Claims (less the amount of the Allowed LBM Subordinated Claims) as of the Petition Date, which shall be satisfied, redeemed, and/or cancelled in full in accordance with the terms and provisions of the New WDT Documents prior to any distributions on account of any New Series A2 WDT Interests, New Series B WDT Interests, New Series C WDT Interests, New Series D WDT Interests, or New Series E WDT Interests, and shall provide for the accrual of interest from April 20, 2022 at a rate of 9% per annum, subject to and in accordance with the waterfall provisions set forth in Article IV.H and Article VI.C hereof. The New Series A1 WDT Interests shall include any New Series A1 WDT Interests issued to the Indenture Trustee on account of any outstanding Indenture Fee and Expense Claims.

130. “New Series A2 WDT Interests” shall mean the new beneficial interests in the Wind Down Trust issued to Holders of Allowed LBM Subordinated Claims in Class 3 pursuant to this Plan in an amount equal to the amount of the Allowed LBM Subordinated Claims, which shall be satisfied, redeemed, and/or cancelled in full in accordance with the terms and provisions of the New WDT Documents prior to any distributions on account of any New Series B WDT Interests, New Series C WDT Interests, New Series D WDT Interests, or New Series E WDT Interests, but following the satisfaction, redemption, and/or cancellation of the New Series A1 WDT Interests, and shall provide for the accrual of interest from April 20, 2022 at a rate of 9% per annum, subject to and in accordance with the waterfall provisions set forth in Article IV.H and Article VI.C hereof.

131. “New Series B WDT Interests” shall mean the new beneficial interests in the Wind Down Trust issued to Holders of Allowed General Unsecured Claims in Class 4(a) pursuant to this Plan in an amount equal to the aggregate amount of Allowed Class 4(a) General Unsecured Claims, which shall be satisfied, redeemed, and/or cancelled in full in accordance with the terms and provisions of the New WDT Documents prior to any distributions on account of any New Series C WDT Interests, New Series D WDT Interests, or New Series E WDT Interests, but following the satisfaction, redemption, and/or cancellation of the New Series A1 WDT Interests and the New Series A2 WDT Interests, subject to and in accordance with the waterfall provisions set forth in Article IV.H and Article VI.C hereof.

132. “New Series C WDT Interests” shall mean the new beneficial interests in the Wind Down Trust issued to Holders of Allowed Series 1 Preferred Interests in Class 8 pursuant to this Plan in an amount equal to the aggregate amount of Allowed Class 8 Series 1 Preferred Interests (based on each Series 1 Preferred Interest having an initial stated value of \$1,000.00 per share), which shall be satisfied, redeemed, and/or cancelled in full in accordance with the terms and provisions of the New WDT Documents on a *pari passu* basis with the New Series D WDT Interests, prior to any distributions on account of any New Series E WDT Interests, but following the satisfaction, redemption, and/or cancellation of the New Series A1 WDT Interests, the New Series A2 WDT Interests, and the New Series B WDT Interests, subject to and in accordance with the waterfall provisions set forth in Article IV.H and Article VI.C hereof.

133. “New Series D WDT Interests” shall mean the new beneficial interests in the Wind Down Trust issued to Holders of Allowed Series 2 Preferred Interests in Class 9 pursuant to this Plan in an amount equal to the aggregate amount of Allowed Class 9 Series 2 Preferred Interests (based on each Series 2 Preferred Interest having an initial stated value of \$1,000.00 per share), which shall be satisfied, redeemed, and/or cancelled in accordance with the terms and provisions of the New WDT Documents on a *pari passu* basis with the New Series C WDT Interests, prior to any distributions on account of any New Series E WDT Interests, but following the satisfaction, redemption, and/or cancellation of the New Series A1 WDT Interests, the New Series A2 WDT Interests, and the New Series B WDT Interests, subject to and in accordance with the waterfall provisions set forth in Article IV.H and Article VI.C hereof.

134. “New Series E WDT Interests” shall mean the new beneficial interests in the Wind Down Trust issued to Holders of Allowed Existing Common Stock in Class 10 pursuant to this Plan in a number equal to the aggregate number of Allowed Class 10 Existing Common Stock. Holders of New Series E WDT Interests shall receive distributions as authorized by the Wind Down Trustee; *provided*, that (a) holders of New Series E WDT Interests shall not be entitled to receive any distributions until all other New WDT Interests have been satisfied, cancelled, and/or redeemed in accordance with the terms and provisions of the New WDT Documents, and (b) nothing herein requires the Wind Down Trustee to authorize any distribution to holders of New Series E WDT Interests.

135. “New WDT Interests” means, collectively, the New Series A1 WDT Interests, the New Series A2 WDT Interests, the New Series B WDT Interests, the New Series C WDT Interests, the New Series D WDT Interests, and the New Series E WDT Interests.

136. “New WDT Documents” means any and all documentation required to implement, issue, and distribute the New WDT Interests, the form and substance of which being subject to the Proponents’ Consent Right, and which documentation may be part of the Wind Down Trust Agreement.

137. “Non-Management Directors” shall mean David F. Chavenson and David de Weese.

138. “Non-Released Parties” shall mean any Entities that are not Released Parties, which Entities shall include, without limitation, Beneficial, its current and former directors and officers (including, without limitation, Bradley K. Heppner, Thomas O. Hicks, Bruce W. Schnitzer, Dennis P. Lockhart, and Peter T. Cangany), HCLP Nominees, L.L.C., the Debtors’ former directors and officers (including, without limitation, Murray Holland and Timothy Evans) in their capacity or capacities as such, and any Entities affiliated with or otherwise related to the foregoing.

139. “Notice and Solicitation Agent” means Donlin, Recano & Company, Inc., in its capacity as such to the Debtors in the Chapter 11 Cases.

140. “Ordinary Course Professional” means an Entity (other than a Professional) retained and compensated by the Debtors in accordance with the Ordinary Course Professionals Order.

141. “Ordinary Course Professionals Order” means the *Order (I) Authorizing the Retention and Compensation of Certain Professionals Utilized in the Ordinary Course of Business and (II) Granting Related Relief* [Dkt. No. 412].

142. “Other Priority Claim” means any Claim against any Debtor entitled to priority in right of payment under section 507 of the Bankruptcy Code, other than an Administrative Claim or a Priority Tax Claim.

143. “Other Secured Claim” means a Secured Claim against any of the Debtors that is not: (a) a Chapford DIP Facility Claim; (b) a Vida DIP Claim; (c) a DLP Secured Claim (otherwise paid in full in Cash before the Effective Date); or (d) a Bond Claim.

144. “Petition Date” means the date on which each of the Debtors commenced the Chapter 11 Cases, as applicable.

145. “Plan” means this *Debtors’ Further Modified Second Amended Joint Chapter 11 Plan*, including the Plan Supplement and all exhibits, supplements, appendices, and schedules, which are incorporated herein by reference and made part of this Plan as if set forth herein, as each may be modified, supplemented, or waived from time to time in accordance with the respective terms thereof.

146. “Plan Supplement” means the compilation of documents and forms of documents, agreements, schedules, and exhibits to this Plan (as may be altered, amended, modified, or supplemented from time to time in accordance with the terms hereof), which may include the following, as applicable and if needed: (a) the identity of the Wind Down Trustee; (b) the identity of the Litigation Trustee; (c) a schedule of the known Retained Causes of Action; (d) a Schedule of Assumed Executory Contracts and Unexpired Leases; (e) the form of Litigation Trust Agreement; (f) the form of Wind Down Trust Agreement; (g) the Wind Down Amount; (h) the form of New WDT Documents, if any; (i) the form of notice of Effective Date; and (j) any other documentation necessary to effectuate or that is contemplated by this Plan. The Debtors shall File the Plan Supplement, which Plan Supplement documents shall be subject to the Proponents’ Consent Right, no later than 5 Business Days before the Voting Deadline. Prior to the Effective Date and in accordance with the terms hereof and subject to the Proponents’ Consent Right, the Plan Supplement may be modified, amended, supplemented, restated, or withdrawn after it is Filed and such changes shall be made publicly available.

147. “Policy Portfolio” means the portfolio of near-duration, intermediate-duration, and long-duration life insurance policies, owned by Debtors DLP IV and DLP VI.

148. “Policy Portfolio Equity Interests” means the direct and indirect equity interests in Portfolio Co., which shall constitute property of the Debtors’ Estates and shall be retained or transferred as described herein.

149. “Portfolio Proceeds Amount” means an amount consisting of the expected net Cash proceeds from the Vida DIP Financing Facility, less: (a) the Estimated Effective Date Shortfall Amount, if any; (b) the Initial Litigation Trust Funding Amount; and (c) the Wind Down Amount.

150. “Portfolio Co.” means, in connection with the Vida DIP Financing Facility and the Vida Exit Financing Facility, the new successor entity, to be created after Confirmation, to which Debtors DLP IV and DLP VI shall transfer the Policy Portfolio.

151. “Priority Tax Claim” means any Claim of a Governmental Unit of the kind specified in section 507(a)(8) of the Bankruptcy Code.

152. “Professional” means an Entity: (a) retained in the Chapter 11 Cases pursuant to a Final Order in accordance with sections 327, 363, or 1103 of the Bankruptcy Code and to be compensated for services rendered before or on the Confirmation Date, pursuant to sections 327, 328, 329, 330, 363, and 331 of the Bankruptcy Code; or (b) awarded compensation and reimbursement by the Bankruptcy Court pursuant to section 503(b)(4) of the Bankruptcy Code, for the avoidance of doubt, a “Professional” shall not include any Ordinary Course Professional.

153. “Professional Fee Escrow Account” means an interest-bearing escrow account to hold and maintain an amount of Cash equal to the Professional Fee Escrow Amount in the manner described in Article II.B of this Plan, which account shall be established by the Debtors on or before the Effective Date and held in trust for the Professionals solely for the purpose of paying Allowed and unpaid Accrued Professional Compensation Claims.

154. “Professional Fee Escrow Amount” means the aggregate Accrued Professional Compensation Claims through the Confirmation Date, as estimated in accordance with Article II.B of this Plan.

155. “Proof of Claim” means a proof of Claim Filed against any of the Debtors in the Chapter 11 Cases.

156. “Proof of Interest” means a proof of Interest Filed against any of the Debtors in the Chapter 11 Cases.

157. “Public L Bonds” means the bonds issued in a registered public offering under the Securities Act pursuant to and under the A&R Indenture.

158. “Proponents’ Consent Right” has the meaning set forth in Article I.G of this Plan.

159. “Reinstate” means reinstate, reinstated, or reinstatement with respect to Claims and Interests, that the Claim or Interest shall be rendered Unimpaired in accordance with section 1124 of the Bankruptcy Code. “Reinstated” and “Reinstatement” shall be correlative meanings.

160. “Released Party” means, collectively, and in each case in their respective capacities as such and subject to the limitations set forth in Article VIII.C hereof: (a) (i) the Debtors and the Wind Down Debtors, (ii) Vida, (iii) the Bondholder Committee and each of its members, (iv) Anthony R. Horton, in his capacities as an Independent Director and director of the Debtors, (v) Jeffrey S. Stein, in his capacities as an officer, an Independent Director, and a director of the Debtors, (vi) Michael A. Tucker, in his capacity as an officer of the Debtors, (vii) the DLP Independent Directors, (viii) FTI Consulting, Inc., (ix) PJT Partners LP, and (x) any other Professional retained by the Debtors, the Independent Directors, the DLP Independent Directors, or the Bondholder Committee by order of the Bankruptcy Court in the Chapter 11 Cases or any

professional retained by any of the members of the Bondholder Committee, each in such capacity; and (b) solely to the extent and on the terms and conditions set forth in this Plan, the LBM Released Parties.

161. “Retained Causes of Action” means all Avoidance Actions, all Causes of Action set forth on a schedule in the Plan Supplement, the form and substance of which being subject to the Proponents’ Consent Right, and any other Causes of Action belonging to the Debtors or their Estates that are not released pursuant to this Plan or other Final Order, and, for the avoidance of doubt, all entitlements, proceeds and rights to payments with respect to any of the foregoing; *provided*, that Retained Causes of Action shall not include any Causes of Action that the Debtors may have against the DLP Independent Directors or their Professionals (in their capacities as such).

162. “Schedule of Assumed Executory Contracts and Unexpired Leases” means the schedule of certain Executory Contracts and Unexpired Leases to be assumed or assumed and assigned by the Debtors pursuant to the Plan, as set forth in the Plan Supplement, in form and substance reasonably acceptable to the Creditor Proponents.

163. “Schedules” means, collectively, the schedules of assets and liabilities, schedules of Executory Contracts and Unexpired Leases, and statements of financial affairs Filed by the Debtors pursuant to section 521 of the Bankruptcy Code and the applicable Bankruptcy Rules, as such Schedules may be amended, modified, or supplemented from time to time.

164. “SEC” means the United States Securities and Exchange Commission.

165. “Secured” means when referring to a Claim: (a) secured by a Lien on property in which the applicable Estate has an interest, which Lien is valid, perfected, and enforceable pursuant to applicable law or by reason of a Bankruptcy Court order, or that is subject to setoff pursuant to section 553 of the Bankruptcy Code, to the extent of the value of the creditor’s interest in such Estate’s interest in such property or to the extent of the amount subject to setoff, as applicable, as determined pursuant to section 506(a) of the Bankruptcy Code and Bankruptcy Rule 3012, as applicable; or (b) Allowed pursuant to the Plan as a Secured Claim.

166. “Securities Act” means the U.S. Securities Act of 1933, as amended, 15 U.S.C. §§ 77a–77aa, and the rules and regulations promulgated thereunder.

167. “Securities Exchange Act” means the U.S. Securities Exchange Act of 1934, as amended, §§ 78a-78qq, and the rules and regulations promulgated thereunder.

168. “Security” shall have the meaning set forth in section 101(49) of the Bankruptcy Code.

169. “Seller Trust L Bonds” means the bonds issued pursuant to and under the 2018 Supplemental Indenture.

170. “Series 1 Preferred Interests” means the redeemable preferred shares issued by Debtor GWGH pursuant to that certain Registration Statement on Form S-1 filed pursuant to the Securities Act and declared effective by the SEC on October 30, 2015, with an initial stated value of \$1,000.00 per share.

171. “Series 2 Preferred Interests” means the redeemable preferred shares issued by Debtor GWGH pursuant to that certain Registration Statement on Form S-1 filed pursuant to the Securities Act and declared effective by the SEC on February 14, 2017, with an initial stated value of \$1,000.00 per share.

172. “Shared Services Agreement” means the Shared Services Agreement dated May 27, 2020, entered into by Debtor GWGH and Beneficient, pursuant to which Beneficient provides certain services to Debtor GWGH.

173. “Special Committee” means the Special Committee formed pursuant to the Resolutions of the Board of Directors of GWGH, dated June 19, 2022 (as subsequently amended and restated on July 13, 2022 and July 17, 2022).

174. “U.S. Trustee” means the Office of the United States Trustee for the Southern District of Texas.

175. “Unexpired Lease” means a lease of nonresidential real property to which one or more of the Debtors is a party that is subject to assumption, assumption and assignment, or rejection under sections 365 or 1123 of the Bankruptcy Code.

176. “Unimpaired” means, with respect to a Class of Claims or Interests, a Claim or an Interest that is unimpaired within the meaning of section 1124 of the Bankruptcy Code.

177. “United States” means the United States of America, its agencies, departments, or agents.

178. “Vida” means Vida Capital.

179. “Vida DIP Claims” means any and all Claims for principal, interest, fees, costs, expenses, disbursements, and any and all other obligations of any kind under the Vida DIP Financing Facility, owing as of the Effective Date.

180. “Vida DIP Financing Facility” means the replacement debtor-in-possession financing facility obtained by the Debtors and approved by the Bankruptcy Court pursuant to the Final Vida Order.

181. “Vida Exit Financing Facility” means the exit financing facility obtained by Portfolio Co., pursuant to this Plan.

182. “Vida Exit Financing Facility Documents” means the agreements memorializing the Vida Exit Financing Facility, and any amendments, modifications, or supplements thereto, and together with any related notes, certificates, agreements, intercreditor agreements, security agreements, mortgages, deeds of trust, documents, and instruments (including any amendments, restatements, supplements, or modifications of any of the foregoing) related to or executed in connection with the Vida Exit Financing Facility; *provided*, that the form and substance of the Vida Exit Financing Facility Documents shall be in form and substance subject to the Proponents’ Consent Right, it being understood that the documents that were Filed at [Dkt. No. 975] are in

substantially final form from the Debtors' perspective and shall be the starting point for Vida Exit Financing Facility Documents.

183. “Wind Down Amount” means an amount set forth in the Plan Supplement to initially fund the Wind Down Debtors, as agreed to by the Debtors and the Creditor Proponents, subject to the Proponents' Consent Right.

184. “Wind Down Budget” means a budget setting forth the basis for, and proposed uses of, the Wind Down Amount.

185. “Wind Down Debtors” means, collectively, a Debtor or any successor or assign thereto, by merger, consolidation, amalgamation, or otherwise, on and after the Effective Date, including any new entity established in connection with the implementation of the Wind Down Transactions (which, for the avoidance of doubt, shall include Portfolio Co.).

186. “Wind Down Documents” means this Plan, the Disclosure Statement, the Confirmation Order, the Plan Supplement, and the various agreements and other documentation formalizing this Plan.

187. “Wind Down Transactions” means the transactions that the Wind Down Trustee determines to be necessary or appropriate to implement the terms of this Plan, and that ultimately result in the dissolution or other termination of the Debtors or Wind Down Debtors, as applicable.

188. “Wind Down Trust” means the liquidation trust established on the Effective Date for the purpose of monetizing the Wind Down Trust Assets.

189. “Wind Down Trust Agreement” means the agreement governing the Wind Down Trust, which shall be Filed as part of the Plan Supplement.

190. “Wind Down Trust Assets” means the following assets, which will ultimately vest in the Wind Down Trust free and clear of all liens, claims, interests, and encumbrances on the Effective Date: (a) the Policy Portfolio Equity Interests; (b) the Debtors' interests in Beneficient; (c) the Debtors' interests in FOXO; (d) all reversionary and beneficial interests in the Litigation Trust; and (e) any remaining Assets of the Debtors', other than the Initial Litigation Trust Assets.

191. “Wind Down Trustee” means Elizabeth C. Freeman or any Affiliate of Elizabeth C. Freeman identified in the Plan Supplement who shall, among other things: (a) be the ultimate governing authority for the Wind Down Debtors; (b) make or facilitate distributions to Holders of Allowed Claims under the Plan; (c) receive for distribution, or direct the distribution of, the proceeds from the realization of the Initial Litigation Trust Assets pursuant to the provisions of this Plan; and (d) oversee and make all decisions with respect to the wind down, dissolution, and liquidation of the Wind Down Debtors and the Wind Down Trust after the Effective Date, including, without limitation, the monetization of the Debtors' Assets (other than Initial Litigation Trust Assets).

B. Rules of Interpretation.

For purposes of the Plan: (1) in the appropriate context, each term, whether stated in the singular or the plural, shall include both the singular and the plural, and pronouns stated in the masculine, feminine, or neuter gender shall include the masculine, feminine, and the neuter gender; (2) unless otherwise specified, any reference herein to a contract, lease, instrument, release, indenture, or other agreement or document being in a particular form or on particular terms and conditions means that the referenced document shall be substantially in that form or substantially on those terms and conditions; (3) unless otherwise specified, any reference herein to an existing document, schedule, or exhibit, whether or not Filed, having been Filed or to be Filed shall mean that document, schedule, or exhibit, as it may thereafter be amended, modified, or supplemented; (4) any reference to an Entity as a Holder of a Claim or Interest includes that Entity's successors; (5) unless otherwise specified, all references herein to "Articles" are references to Articles hereof or hereto; (6) unless otherwise specified, all references herein to exhibits are references to exhibits in the Plan Supplement; (7) unless otherwise specified, the words "herein," "hereof," and "hereto" refer to the Plan in its entirety rather than to a particular portion of the Plan; (8) subject to the provisions of any contract, certificate of incorporation, by-law, instrument, release, or other agreement or document entered into in connection with the Plan, the rights and obligations arising pursuant to the Plan shall be governed by, and construed and enforced in accordance with the applicable federal law, including the Bankruptcy Code and Bankruptcy Rules; (9) captions and headings to Articles are inserted for convenience of reference only and are not intended to be a part of or to affect the interpretation of the Plan; (10) unless otherwise specified herein, the rules of construction set forth in section 102 of the Bankruptcy Code shall apply to the Plan; (11) any term used in capitalized form herein that is not otherwise defined but that is used in the Bankruptcy Code or the Bankruptcy Rules shall have the meaning assigned to that term in the Bankruptcy Code or the Bankruptcy Rules, as the case may be; (12) all references to docket numbers of documents Filed in the Chapter 11 Cases are references to the docket numbers under the Bankruptcy Court's CM/ECF system; (13) all references to statutes, regulations, orders, rules of courts, and the like shall mean as amended from time to time, and as applicable to the Chapter 11 Cases, unless otherwise stated; and (14) any immaterial effectuating provisions may be interpreted in such a manner that is consistent with the overall purpose and intent of the Plan all without further notice to or action, order, or approval of the Bankruptcy Court or any other Entity, provided that no effectuating provision shall be deemed immaterial if it has any substantive legal or economic effect on any party. References in the Plan to the Debtors shall mean the Debtors or any successor thereto, by merger, consolidation, or otherwise, on or after the Effective Date, as applicable.

C. Computation of Time.

The provisions of Bankruptcy Rule 9006(a) shall apply in computing any period of time prescribed or allowed in the Plan or Confirmation Order. If the date on which a transaction may occur pursuant to the Plan shall occur on a day that is not a Business Day, then such transaction shall instead occur on the next succeeding Business Day.

D. Governing Law.

Unless a rule of law or procedure is supplied by federal law (including the Bankruptcy Code and Bankruptcy Rules) or unless otherwise specifically stated, the laws of the State of New

York, without giving effect to the principles of conflict of laws (except for Sections 5-1401 and 5-1402 of the General Obligations Law of the State of New York), shall govern the rights, obligations, construction, and implementation of the Plan, any agreements, documents, instruments, or contracts executed or entered into in connection with the Plan (except as otherwise set forth in those agreements, in which case the governing law of such agreement shall control); *provided* that corporate or limited liability company governance matters relating to the Debtors or the Wind Down Debtors shall be governed by the laws of the state of incorporation or formation (as applicable) of the applicable Debtor or Wind Down Debtor, as applicable.

E. Reference to Monetary Figures.

All references in the Plan to monetary figures shall refer to the legal tender of the United States, unless otherwise expressly provided.

F. Controlling Document.

Except as set forth in the Plan, to the extent that any provision of any other Wind Down Document or any document or other exhibits, schedules, appendices, supplements, or amendments of any document referenced in the Plan conflict with or are in any way inconsistent with any provision of the Plan, the Plan shall govern and control; *provided* that, with respect to any conflict or inconsistency between the Plan and the Wind Down Trust Agreement and/or the Litigation Trust Agreement (each in the form executed on or before the Effective Date), such Wind Down Trust Agreement and/or Litigation Trust Agreement, as applicable, shall govern; *provided, further*, that, with respect to any conflict or inconsistency between the Plan and the Plan Supplement (including the Wind Down Trust Agreement and the Litigation Trust Agreement) on the one hand, and the Confirmation Order on the other hand, the Confirmation Order shall govern.

G. Proponents' Consent Right.

The Debtors submit this Plan with the Debtors and the Creditor Proponents co-proposing this Plan within the meaning of section 1129 of the Bankruptcy Code. Per the Mediation Agreement, the Debtors and the Creditor Proponents have the right, acting separately (the "Proponents' Consent Right") to review and consent to the form and substance of the: (1) the Disclosure Statement accompanying this Plan; (2) this Plan; and (3) the Plan Supplement, including trust agreements and other applicable documents. Per the Mediation Agreement, the scope of the Proponents' Consent Right is: (a) to ensure that such documents are consistent with, and can effectuate the settlement memorialized in the Mediation Agreement; and (b) to address issues not explicitly covered by the Mediation Agreement but are customary or required for a plan of reorganization.

Following the Filing of this Plan, submitted by the Debtors, the Bondholder Committee, and LBM as co-proponents, dated as of March 27, 2023, in the event the Debtors and the Creditor Proponents cannot agree to the form and substance of any document in connection with this Plan (and such document is subject to the Proponents' Consent Rights or other consent rights hereunder) or any decision which requires the consent of the Creditor Proponents, by the applicable deadline for Filing such document hereunder, any such dispute shall be submitted to the mediator, Judge David Jones. To the extent of any remaining disputes following such mediation, then, pending

final resolution thereof, any of the Debtors and the Creditor Proponents may File its own version of any such disputed document by the applicable deadline therefor. In such event: (x) the Filing of the competing versions of any such disputed document shall be deemed to have satisfied any such Filing deadline hereunder; (y) the Debtors and the Creditor Proponents shall continue as co-proponents of this Plan for all purposes; and (z) the final form of any such disputed document will be subsequently resolved through either mediation with Judge Jones or by order of the Bankruptcy Court.

For the avoidance of doubt, this Article I.G applies to and supersedes (in the event of conflict) every provision of this Plan that refers to any consent right of the Creditor Proponents (except with respect to the consent right described in Article X.C hereof). Further, in the event of any dispute, and for the avoidance of doubt, the Debtors and the Creditor Proponents agree to support this Plan (including any amended plan) and any document comprising the Plan Supplement, provided that the form and substance of such document is resolved, if necessary, pursuant to the dispute resolution mechanic set forth above.

ARTICLE II.
ADMINISTRATIVE CLAIMS, ACCRUED PROFESSIONAL FEE COMPENSATION
CLAIMS, DIP CLAIMS, PRIORITY TAX CLAIMS, INDENTURE DIMINUTION
CLAIMS, AND SUBSTANTIAL CONTRIBUTION CLAIMS

A. Administrative Claims.

Except as otherwise agreed to by the Holder of an Allowed Administrative Claim and the Debtors or Wind Down Debtors or as provided herein, on the Administrative Claims Payment Date (or within a reasonable period of time after such Claims become Allowed Claims), each Holder of an Allowed Administrative Claim shall receive payment in full in Cash in full and final satisfaction, settlement, discharge, and release of such Allowed Administrative Claim in accordance with the following: (1) if an Administrative Claim is Allowed on or prior to the Effective Date, on the Effective Date or as soon as reasonably practicable thereafter (or, if not then due, when such Allowed Administrative Claim is due or as soon as reasonably practicable thereafter); (2) if such Administrative Claim is not Allowed as of the Effective Date, no later than 30 days after the date on which an order Allowing such Administrative Claim becomes a Final Order, or as soon as reasonably practicable thereafter; (3) if such Allowed Administrative Claim is based on liabilities incurred by the Debtors in the ordinary course of their business after the applicable Petition Date in accordance with the terms and conditions of the particular transaction giving rise to such Allowed Administrative Claim without any further action by the Holder of such Allowed Administrative Claim; (4) at such time and upon such terms as may be agreed upon by such Holder and the Debtors or the Wind Down Debtors, as applicable; or (5) at such time and upon such terms as set forth in an order of the Bankruptcy Court.

EXCEPT AS OTHERWISE PROVIDED BY THIS PLAN, THE CONFIRMATION ORDER, OR A FINAL ORDER PREVIOUSLY ENTERED BY THE BANKRUPTCY COURT (INCLUDING THE FINAL VIDA ORDER), UNLESS PREVIOUSLY FILED, REQUESTS FOR PAYMENT OF ADMINISTRATIVE CLAIMS MUST BE FILED AND SERVED ON THE DEBTORS (OR THE WIND DOWN DEBTORS, AS APPLICABLE) NO LATER THAN THE CLAIMS BAR DATE APPLICABLE TO ADMINISTRATIVE

CLAIMS PURSUANT TO THE PROCEDURES SPECIFIED IN THE CONFIRMATION ORDER AND THE NOTICE OF THE EFFECTIVE DATE; *PROVIDED*, THAT THE FOREGOING SHALL NOT APPLY TO ACCRUED PROFESSIONAL COMPENSATION CLAIMS, INDEPENDENT DIRECTOR FEE CLAIMS, THE INDENTURE DIMINUTION CLAIMS, THE ALLOWED AHC SUBSTANTIAL CONTRIBUTION CLAIM, OR CLAIMS ARISING UNDER SECTION 503(b)(1)(D) OF THE BANKRUPTCY CODE.

HOLDERS OF ADMINISTRATIVE CLAIMS THAT ARE REQUIRED TO FILE AND SERVE A REQUEST FOR PAYMENT OF SUCH ADMINISTRATIVE CLAIMS BY THE CLAIMS BAR DATE APPLICABLE TO ADMINISTRATIVE CLAIMS THAT DO NOT FILE AND SERVE SUCH A REQUEST BY THE CLAIMS BAR DATE APPLICABLE TO ADMINISTRATIVE CLAIMS SHALL BE FOREVER BARRED, ESTOPPED, AND ENJOINED FROM ASSERTING SUCH ADMINISTRATIVE CLAIMS AGAINST THE DEBTORS, THE WIND DOWN DEBTORS, THE DEBTORS' ESTATES, OR THEIR RESPECTIVE PROPERTY, AND SUCH ADMINISTRATIVE CLAIMS SHALL BE DEEMED DISCHARGED AS OF THE EFFECTIVE DATE. ALL SUCH CLAIMS SHALL BE SUBJECT TO THE PERMANENT INJUNCTION SET FORTH IN ARTICLE VIII.G HEREIN.

B. Accrued Professional Compensation Claims.

1. Professional Fee Escrow Account.

No later than one Business Day prior to the Effective Date, the Debtors shall fund the Professional Fee Escrow Account with the Debtors' Cash on hand in the amount of the aggregate Professional Fee Escrow Amount for all Professionals; *provided* that each Professional's respective share of the Professional Fee Escrow Account shall be reduced, on a dollar-for-dollar basis, by any unused retainer held by such Professional as of the Effective Date.² The Professional Fee Escrow Account shall be maintained in trust for the Professionals and the funds held in the Professional Fee Escrow Account shall not be considered property of the Debtors' Estates or any successor to the Debtors; *provided* that, notwithstanding the foregoing, the Wind Down Trust shall have a reversionary interest in the excess, if any, of the amount of the Professional Fee Escrow Account over the aggregate Allowed Accrued Professional Compensation Claims to be paid from the Professional Fee Escrow Account, and such excess shall be paid to the Wind Down Debtors

² For the avoidance of doubt, nothing contained in this Plan shall be deemed to resolve any of the issues relating to the payment of fees and expenses for services rendered by Willkie Farr & Gallagher, LLP prior to the Petition Date, including with respect to all Cash held as a retainer by the Debtors or Willkie Farr & Gallagher, LLP pursuant to the *Order Modifying the Automatic Stay and Authorizing the Use of Estate Property, to the Extent Applicable, to Allow Payment, Reimbursement and/or Advancement of Defense Costs Under the Insurance Policies* [Dkt. No. 754] (the "D&O Insurance Order") and the *Stipulation and Agreed Order Regarding the Order Modifying the Automatic Stay and Authorizing Use of Estate Property, to the Extent Applicable, to Allow Payment, Reimbursement and/or Advancement of Defense Costs Under Insurance Policies* [Dkt. No. 825]. In accordance with the D&O Insurance Order, any and all such issues remain subject to resolution through either (i) further order of the Bankruptcy Court or (ii) agreement between the Debtors (or, if after the Effective Date, the Wind Down Trustee), Willkie Farr & Gallagher, LLP, and the Bondholder Committee (or, if after the Effective Date, the Litigation Trustee).

(and distributed to the Wind Down Trust, if determined by the Wind Down Trustee) without any further notice to or action, order, or approval of the Bankruptcy Court or any other Entity.

2. Final Fee Applications and Payment of Accrued Professional Compensation Claims.

All final requests for payment of Claims of a Professional for services rendered and reimbursement of expenses incurred prior to the Confirmation Date shall be Filed no later than the first Business Day that is 60 days after the Confirmation Date. After notice and an opportunity for a hearing in accordance with the procedures established by the Bankruptcy Code and prior Bankruptcy Court orders, the Allowed amounts of such Accrued Professional Compensation Claims shall be determined by the Bankruptcy Court. The amount of Accrued Professional Compensation Claims owing to the applicable Professionals shall be paid in Cash to such Professionals from funds held in the Professional Fee Escrow Account after such Claims are Allowed by a Final Order. After all Accrued Professional Compensation Claims have been paid in full, the Final Order Allowing such Accrued Professional Compensation Claims shall direct the escrow agent to return any excess amounts to the Wind Down Trustee without further notice to or action, order, or approval of the Bankruptcy Court or any other Entity.

3. Estimate of Professional Fee Compensation Claims.

To receive payment for unbilled fees and expenses incurred through the Confirmation Date, the Professionals shall provide a reasonable and good faith estimate of their Accrued Professional Compensation Claims before and as of the Confirmation Date and shall deliver such estimate to the Debtors no later than three Business Days before the Confirmation Date; *provided*, that such estimate shall not be considered an admission with respect to the fees and expenses of such Professional and such Professionals are not bound to any extent by the estimates. If a Professional does not provide an estimate, the Debtors may estimate the unbilled fees and expenses of such Professional; *provided, further*, that such estimate shall not be binding or considered an admission with respect to the fees and expenses of such Professional.

4. Post-Confirmation Fees and Expenses.

Except as otherwise specifically provided in this Plan, from and after the Confirmation Date, the Debtors shall, in the ordinary course of business and without any further notice to or action, order, or approval of the Bankruptcy Court, pay in Cash the reasonable and documented legal, professional, or other fees and expenses related to implementation and Consummation of the Plan incurred by the Debtors or the Bondholder Committee; *provided*, that each Entity seeking such payment shall promptly provide copies of its invoices to the Debtors or the Wind Down Trustee, as applicable, and the Bondholder Committee, and the Bankruptcy Court shall have exclusive jurisdiction over any objections raised to the amount of the fees and expenses proposed to be paid, which objections may only be raised within 14 days after receipt thereof. In the event that within 14 days from receipt of such invoices, the Debtors or the Wind Down Trustee, as applicable, or the Bondholder Committee raises an objection to a particular invoice, and the parties are unable to resolve any dispute regarding the fees and expenses included in such invoice, the Bankruptcy Court shall hear and determine such dispute. Upon the Confirmation Date, any requirement that Professionals and Ordinary Course Professionals comply with sections 327

through 331 and 1103 of the Bankruptcy Code, the Interim Compensation Order, or the Ordinary Course Professionals Order, in seeking retention or compensation for services rendered after such date shall terminate, and the Debtors or the Wind Down Trustee, as applicable, may employ and pay any Professional or Ordinary Course Professional in the ordinary course of business without any further notice to or action, order, or approval of the Bankruptcy Court. Furthermore, as of the date one day prior to the Effective Date, the obligation of any Ordinary Course Professional to File a fee application pursuant to the Ordinary Course Professionals Order shall be deemed waived, and, on the Effective Date, the Debtors or the Wind Down Trustee, as applicable, may pay any Ordinary Court Professional for fees incurred or accrued after the Effective Date in the ordinary course of business without any further notice to or action, order, or approval of the Bankruptcy Court.

C. Chapford DIP Facility Claims.

On or prior to the Effective Date, and to the extent each such Chapford DIP Facility Claims have not previously been satisfied in full in connection with the consummation of the Vida DIP Financing Facility or otherwise, each Holder of an Allowed Chapford DIP Facility Claim shall receive payment in full in Cash; *provided, however*, for the avoidance of doubt, the Chapford DIP Facility Claims shall not include the purported Alternate Stalking Horse Fee, as defined and referenced in the Chapford Final DIP Order (including any professional fees and expenses relating in any manner to the assertion of the purported Alternate Stalking Horse Fee).

D. Vida DIP Claims.

No later than the Effective Date, the Vida DIP Claims will be deemed satisfied in connection with the Debtors' exercise of the exit financing option and upon the closing under the Vida Exit Financing Facility Documents.

E. DLP Secured Claims.

All Allowed DLP Secured Claims will be satisfied by payment in full in Cash on or prior to the Effective Date from proceeds of the Vida DIP Financing Facility; *provided*, that, notwithstanding the foregoing, to the extent that all Allowed DLP Secured Claims are not paid in full in cash before the Effective Date, they shall be treated as Other Secured Claims. Any Disputed portion of the DLP Secured Claims shall be treated in accordance with Article VII hereof.

F. Indenture Diminution Claims.

Any Allowed Indenture Diminution Claims will be satisfied by one or more payments in Cash after the Effective Date from proceeds realized by the Litigation Trust, pursuant to and in accordance with Article VI.C hereof.

G. Priority Tax Claims.

Except to the extent that a Holder of an Allowed Priority Tax Claim agrees to a less favorable treatment, in full and final satisfaction, settlement, and release of and in exchange for each Allowed Priority Tax Claim, each Holder of such Allowed Priority Tax Claim shall be treated in accordance with the terms set forth in section 1129(a)(9)(C) of the Bankruptcy Code.

H. Allowed AHC Substantial Contribution Claim.

In full and final resolution of any claims that the Ad Hoc Broker/Dealer Committee could assert for making a substantial contribution to these Chapter 11 Cases, the Debtors agree to pay the actual and reasonable fees and expenses of the Ad Hoc Broker/Dealer Committee not to exceed \$1,000,000.

I. Substantial Contribution Compensation and Expenses.

Any Entity that requests compensation or expense reimbursement for making a substantial contribution in the Chapter 11 Cases pursuant to Bankruptcy Code sections 503(b)(3), (4), and (5) (except with respect to the Allowed AHC Substantial Contribution Claim) must File an application and serve such application on counsel to the Debtors or the Wind Down Debtors, as applicable, and the Bondholder Committee and as otherwise required by the Bankruptcy Court, the Bankruptcy Code, and the Bankruptcy Rules, on or before the Claims Bar Date applicable to Administrative Claims.

**ARTICLE III.
CLASSIFICATION AND TREATMENT OF CLAIMS AND INTERESTS**

In accordance with section 1123(a)(1) of the Bankruptcy Code, the Chapford DIP Facility Claims, the Vida DIP Claims, Administrative Claims, Accrued Professional Fee Compensation Claims, and Priority Tax Claims have not been classified and, thus, are excluded from the Classes of Claims and Interests set forth in Article III of this Plan.

A. Summary of Classification.

A Claim or Interest is classified in a particular Class pursuant to sections 1122 and 1123(a)(1) of the Bankruptcy Code only to the extent that the Claim or Interest qualifies within the description of that Class and is classified in other Classes to the extent that any portion of the Claim or Interest qualifies within the description of such other Classes. Except as provided below, the Plan shall apply as a separate Plan for each of the Debtors. A Claim or Interest is also classified in a particular Class for the purpose of receiving distributions pursuant to the Plan only to the extent that such Claim or Interest is an Allowed Claim or Allowed Interest in that Class and has not been paid, released, disallowed, or otherwise satisfied before the Effective Date.

Class	Claims and Interests	Status	Voting Rights
Class 1	Other Secured Claims	Unimpaired	Deemed to Accept
Class 2	Other Priority Claims	Unimpaired	Deemed to Accept
Class 3	Bond Claims	Impaired	Entitled to Vote
Class 4(a)	General Unsecured Claims	Impaired	Entitled to Vote
Class 4(b)	GUC Convenience Claims	Unimpaired	Deemed to Accept
Class 5	DLP Entity General Unsecured Claims	Unimpaired	Deemed to Accept
Class 6	Intercompany Claims	Impaired	Deemed to Reject
Class 7	Intercompany Interests	Impaired	Deemed to Reject
Class 8	Series 1 Preferred Interests	Impaired	Entitled to Vote

Class 9	Series 2 Preferred Interests	Impaired	Entitled to Vote
Class 10	Existing Common Interests	Impaired	Entitled to Vote

B. Treatment of Claims and Interests.

The treatment provided to each Class relating to each of the Debtors for distribution purposes and voting rights are specified below.

1. Class 1 — Other Secured Claims.

- (a) *Classification:* Class 1 consists of all Other Secured Claims.
- (b) *Treatment:* Except to the extent that a Holder of an Other Secured Claim agrees to a less favorable treatment of its Allowed Claim, on the Effective Date, each Holder of an Allowed Other Secured Claim shall receive, at the Debtors' option: (i) payment in full in Cash; (ii) the collateral securing its Allowed Other Secured Claim; (iii) Reinstatement of its Allowed Other Secured Claim; or (iv) such other treatment rendering its Allowed Other Secured Claim Unimpaired in accordance with section 1124 of the Bankruptcy Code.
- (c) *Voting:* Class 1 is Unimpaired under the Plan. Holders of Claims in Class 1 are conclusively presumed to accept the Plan pursuant to section 1126(f) of the Bankruptcy Code. Therefore, such Holders are not entitled to vote to accept or reject the Plan.

2. Class 2 — Other Priority Claims.

- (a) *Classification:* Class 2 consists of all Other Priority Claims.
- (b) *Treatment:* Except to the extent that a Holder of an Allowed Other Priority Claim agrees to a less favorable treatment of its Allowed Claim, each Holder of an Allowed Other Priority Claim shall receive treatment in a manner consistent with section 1129(a)(9) of the Bankruptcy Code.
- (c) *Voting:* Class 2 is Unimpaired under the Plan. Holders of Claims in Class 2 are conclusively presumed to accept the Plan pursuant to section 1126(f) of the Bankruptcy Code. Therefore, such Holders are not entitled to vote to accept or reject the Plan.

3. Class 3 — Bond Claims.

- (a) *Classification:* Class 3 consists of all Bond Claims.
- (b) *Treatment:* Except to the extent that a Holder of a Bond Claim agrees to a less favorable treatment of its Allowed Claim, each such Holder shall receive, as applicable, as follows:

- (i) each Holder of an Allowed Bond Claim (other than the LBM Subordinated Claims) shall receive, on the Effective Date, its pro rata share of the Portfolio Proceeds Amount, if any; *provided, however*, that the Indenture Fee and Expense Claim shall be satisfied first from the Portfolio Proceeds Amount prior to any such further pro rata distributions in accordance with this subsection (i);
- (ii) each Holder of an Allowed Bond Claim (other than the LBM Subordinated Claims) shall receive, on the Effective Date (or as soon as practicably thereafter), its pro rata share of the New Series A1 WDT Interests. The New Series A1 WDT Interests may be redeemed at any time without penalty at stated value and, pending any such redemption, shall be entitled to Cash distributions pursuant to the priority of payment waterfalls described in Article IV.H and Article VI.C. Any New Series A1 WDT Interests issued to the Indenture Trustee on account of any outstanding Indenture Fee and Expense Claims shall be expressly senior in all respects to any New Series A1 WDT Interests issued to Holders on account of their respective Allowed Class 3 Bond Claims; and
- (iii) each Holder of an Allowed LBM Subordinated Claim shall receive, on the Effective Date, its pro rata share of the New Series A2 WDT Interests. The New Series A2 WDT Interests may be redeemed at any time without penalty at stated value and, pending any such redemption, shall be entitled to Cash distributions, but only pursuant to the priority of payment waterfalls described in Article IV.H and Article VI.C of this Plan.

The pro rata distributions on account of the Allowed Class 3 Bond Claims shall be calculated based upon the sum of the aggregate amount of Allowed Class 3 Bond Claims (less any LBM Subordinated Claims) as of the Petition Date with respect to subsections (i) and (ii) above, and the sum of the aggregate amount of Allowed LBM Subordinated Claims as of the Petition Date with respect to subsection (iii) above, and after accounting for each Holder's receipt of its pro rata share of the Portfolio Proceeds Amount, as applicable.

- (c) *Voting*: Class 3 is Impaired under the Plan. Holders of Allowed Claims in Class 3 are entitled to vote to accept or reject the Plan.

4. Class 4(a) — General Unsecured Claims.

- (a) *Classification*: Class 4(a) consists of all General Unsecured Claims.
- (b) *Treatment*: Except to the extent that a Holder of a General Unsecured Claim agrees to a less favorable treatment of its Allowed Claim, on the Effective Date, each Holder of an Allowed General Unsecured Claim shall receive its

pro rata share of the New Series B WDT Interests. The New Series B WDT Interests may be redeemed at any time without penalty at stated value and, pending any such redemption, shall be entitled to Cash distributions, but only pursuant to the priority of payment waterfalls described in Article IV.H and Article VI.C of this Plan.

- (c) *Voting:* Class 4(a) is Impaired under the Plan. Holders of Allowed Claims in Class 4(a) are entitled to vote to accept or reject the Plan.

5. Class 4(b) — GUC Convenience Claims.

- (a) *Classification:* Class 4(b) consists of all GUC Convenience Claims.
- (b) *Treatment:* Except to the extent that a Holder of a GUC Convenience Claim agrees to a less favorable treatment of its Allowed Claim, in full and final satisfaction, settlement, release, and discharge of, and in exchange for each Allowed GUC Convenience Claim, each Holder thereof shall receive, and the option of the applicable Debtor, either:
 - (i) payment in full in Cash of the due and unpaid portion of its Allowed GUC Convenience Claim on the later of (x) the Effective Date (or as soon thereafter as reasonably practicable), or (y) as soon as practicable after the date such Claim becomes due and payable; or
 - (ii) such other treatment rendering its Allowed GUC Convenience Claim Unimpaired.
- (c) *Voting:* Class 4(b) is Unimpaired under the Plan. Holders of Claims in Class 4(b) are conclusively presumed to accept the Plan pursuant to section 1126(f) of the Bankruptcy Code. Therefore, such Holders are not entitled to vote to accept or reject the Plan.

6. Class 5 — DLP Entity General Unsecured Claims.

- (a) *Classification:* Class 5 consists of all DLP Entity General Unsecured Claims.
- (b) *Treatment:* On the Effective Date or as soon thereafter as such Claim becomes an Allowed Claim, each Holder of an Allowed DLP Entity General Unsecured Claim shall receive payment in full in Cash.
- (c) *Voting:* Class 5 is Unimpaired under the Plan. Holders of Claims in Class 5 are conclusively presumed to accept the Plan pursuant to section 1126(f) of the Bankruptcy Code. Therefore, such Holders are not entitled to vote to accept or reject the Plan.

7. Class 6 — Intercompany Claims.

- (a) *Classification:* Class 6 consists of all Intercompany Claims.
- (b) *Treatment:* Other than the Policy Portfolio Equity Interests, which shall be transferred to the Wind Down Trust as set forth herein, on the Effective Date, any Debtor's Claim against any other Debtor shall be deemed satisfied except to the extent necessary to effectuate the other terms of this Plan.
- (c) *Voting:* Class 6 is Impaired under the Plan. Holders of Claims in Class 6 are deemed to have rejected the Plan pursuant to section 1126(g) of the Bankruptcy Code and are not entitled to vote to accept or reject the Plan.

8. Class 7 — Intercompany Interests.

- (a) *Classification:* Class 7 consists of all Intercompany Interests.
- (b) *Treatment:* On the Effective Date, any Debtor's equity Interests in any other Debtor shall be deemed cancelled except to the extent necessary to effectuate the other terms of this Plan.
- (c) *Voting:* Class 7 is Impaired under the Plan. Holders of Interests in Class 7 are deemed to have rejected the Plan pursuant to section 1126(g) of the Bankruptcy Code and are not entitled to vote to accept or reject the Plan.

9. Class 8 — Series 1 Preferred Interests.

- (a) *Classification:* Class 8 consists of all Series 1 Preferred Interests.
- (b) *Treatment:* On the Effective Date, and in all instances, each Holder of a Series 1 Preferred Interest shall receive its pro rata share of the New Series C WDT Interests. The New Series C WDT Interests may be redeemed at any time without penalty at stated value and, pending any such optional redemption, shall be entitled to Cash distributions, but only pursuant to the priority of payment waterfalls described in Article IV.H and Article VI.C herein. The New Series C WDT Interests shall rank junior in right of payment to the New Series A1 WDT Interests, the New Series A2 WDT Interests, and the New Series B WDT Interests, *pari passu* with the New Series D WDT Interests, and senior to the New Series E WDT Interests.
- (c) *Voting:* Class 8 is Impaired under the Plan. Holders of Allowed Interests in Class 8 are entitled to vote to accept or reject the Plan.

10. Class 9 — Series 2 Preferred Interests.

- (a) *Classification:* Class 9 consists of all Series 2 Preferred Interests.

- (b) *Treatment:* On the Effective Date, and in all instances, each Holder of a Series 2 Preferred Interest shall receive its pro rata share of the New Series D WDT Interests. The New Series D WDT Interests may be redeemed at any time without penalty at stated value and, pending any such optional redemption, shall be entitled to Cash distributions, but only pursuant to the priority of payment waterfalls described in Article IV.H and Article VI.C herein. The New Series D WDT Interests shall rank junior in right of payment to the New Series A1 WDT Interests, the New Series A2 WDT Interests, and the New Series B WDT Interests, *pari passu* with the New Series C WDT Interests, and senior to the New Series E WDT Interests.
- (c) *Voting:* Class 9 is Impaired under the Plan. Holders of Allowed Interests in Class 9 are entitled to vote to accept or reject the Plan.

11. Class 10 — Common Stock in GWGH.

- (a) *Classification:* Class 10 consists of all Holders of Common Stock in GWGH.
- (b) *Treatment:* On the Effective Date, each Holder of Common Stock in GWGH shall receive its pro rata share of the New Series E WDT Interests. The holders of the New Series E WDT Interests shall only be entitled to Cash distributions upon the satisfaction and redemption of all other classes of New WDT Interests, pursuant to the priority of payment waterfalls described in Article IV.H and Article VI.C herein.
- (c) *Voting:* Class 10 is Impaired under the Plan. Holders of Allowed Interests in Class 10 are entitled to vote to accept or reject the Plan.

C. Special Provision Governing Unimpaired Claims.

Except as otherwise provided in the Plan, nothing under the Plan shall affect the rights of the Debtors or Wind Down Debtors in respect of any Unimpaired Claims, including all rights in respect of legal and equitable defenses to or setoffs or recoupments against any such Unimpaired Claims. Unimpaired Claims shall remain Disputed Claims under the Plan until such Claims are Allowed.

D. Elimination of Vacant Classes.

Any Class of Claims or Interests that does not have a Holder of an Allowed Claim or Allowed Interest or a Claim or Interest temporarily Allowed by the Bankruptcy Court as of the date of the Confirmation Hearing shall be deemed eliminated from the Plan for purposes of voting to accept or reject the Plan and for purposes of determining acceptance or rejection of the Plan by such Class pursuant to section 1129(a)(8) of the Bankruptcy Code.

E. Voting Classes; Presumed Acceptance by Non-Voting Classes.

If a Class contains Claims or Interests eligible to vote and no Holders of Claims or Interests eligible to vote in such Class vote to accept or reject the Plan, the Plan shall be presumed accepted by the Holders of such Claims or Interests in such Class; *provided, however*, that such Class shall not qualify as an impaired accepting class under section 1129(a)(8) of the Bankruptcy Code.

F. Subordinated Claims.

The allowance, classification, and treatment of all Allowed Claims and Allowed Interests and the respective distributions and treatments under the Plan take into account and conform to the relative priority and rights of the Claims and Interests in each Class in connection with any contractual, legal, and equitable subordination rights relating thereto, whether arising under general principles of equitable subordination, section 510(b) of the Bankruptcy Code, or otherwise. Pursuant to section 510 of the Bankruptcy Code, the Debtors or Wind Down Debtors reserve the right to re-classify any Allowed Claim (including the LBM L Bond Claims to the extent provided by Article IV.I hereof) or Allowed Interest in accordance with any contractual, legal, or equitable subordination relating thereto.

G. Presumed Acceptance of Plan.

If a Class contains Claims eligible to vote and no Holder of Claims eligible to vote in such Class votes to accept or reject the Plan, the Plan shall be presumed accepted by the Holders of such Claims in such Class. Classes 1, 2, 4(b), and 5 are Unimpaired under this Plan. Therefore, the Holders of Claims in such Classes are deemed to have accepted this Plan pursuant to section 1126(f) of the Bankruptcy Code and are not entitled to vote to accept or reject the Plan.

H. Presumed Rejection of Plan.

Classes 6 and 7 are Impaired, and the Holders of Claims or Interests in such Classes shall receive no distribution under the Plan on account of such Claims or Interests. Therefore, the Holders of Claims or Interests in such Classes are deemed to have rejected this Plan pursuant to section 1126(g) of the Bankruptcy Code and are not entitled to vote to accept or reject this Plan.

I. Acceptance by Impaired Classes of Claims.

Pursuant to section 1126(c) of the Bankruptcy Code and except as otherwise provided in section 1126(e) of the Bankruptcy Code, an Impaired Class of Claims has accepted this Plan if the Holders of at least two-thirds (2/3) in dollar amount and more than one-half (1/2) in number of the Allowed Claims in such Class actually voting have voted to accept this Plan.

J. Acceptance by Impaired Classes of Interests.

Pursuant to section 1126(d) of the Bankruptcy Code and except as otherwise provided in section 1126(e) of the Bankruptcy Code, an Impaired Class of Interests has accepted this Plan if the Holders of at least two-thirds (2/3) in dollar amount of the Allowed Interests in such Class actually voting have voted to accept this Plan.

K. Confirmation Pursuant to Sections 1129(a)(10) and 1129(b) of the Bankruptcy Code.

Section 1129(a)(10) of the Bankruptcy Code shall be satisfied for purposes of Confirmation by acceptance of this Plan by Classes 3 or 4(a). The Debtors request Confirmation of this Plan under section 1129(b) of the Bankruptcy Code with respect to any Impaired Class that does not accept this Plan pursuant to section 1126 of the Bankruptcy Code. The Debtors reserve the right to modify this Plan, subject to the Proponents' Consent Right, including the Plan Supplement, in order to satisfy the requirements of section 1129(b) of the Bankruptcy Code, if necessary.

L. Controversies Regarding Impairment.

If a controversy arises as to whether any Claims or Interests, or any Class of Claims or Interests, are Impaired, the Bankruptcy Court shall, after notice and a hearing, determine such controversy on or before the Confirmation Date.

**ARTICLE IV.
MEANS FOR IMPLEMENTATION OF THE PLAN**

A. Wind Down Trust.

1. Wind Down Trust Generally.

The Confirmation Order shall provide that, upon the occurrence of the Effective Date, the Wind Down Trust shall be deemed established in accordance with the Wind Down Trust Agreement and the Plan. On the Effective Date, the Wind Down Trust shall commence the taking of all necessary steps to wind down the business affairs of the Debtors.

The Wind Down Trust Assets shall be deemed disbursed by the Debtors and transferred to the Wind Down Trust on the Effective Date, the proceeds of which shall be distributed in accordance with the waterfall set forth in Article IV.H. The powers, authorities, responsibilities, and duties of the Wind Down Trust and the Wind Down Trustee are set forth in and shall be governed by this Plan and the Wind Down Trust Agreement. The Wind Down Trust Agreement, which shall be part of the Plan Supplement, shall be consistent with the Plan and shall contain provisions customary to trust agreements utilized in comparable circumstances, including, without limitation, any and all provisions necessary to ensure the continued treatment of the Wind Down Trust as a grantor trust. The Wind Down Trust Agreement may provide powers, duties, and authorities in addition to those explicitly stated herein, but only to the extent that such powers, duties, and authorities do not affect the status of the Wind Down Trust as a "liquidating trust" for United States federal income tax purposes or as an entity that can fall within the exception from registration in Section 7 of the 1940 Act for activities of companies that are merely incidental to their dissolution.

Notwithstanding anything to the contrary herein, the Wind Down Trust's sole purpose is to liquidate the Wind Down Trust Assets with a view towards maximizing the value of such assets for the benefit of New WDT Interest holders, and promptly distributing such liquidation proceeds (in accordance with the provisions of this Plan) to New WDT Interest holders. The Wind Down Trust will have no going concern operations and will not be permitted to continue or engage in the conduct of a trade or business or to make any investments (other than holding, on a temporary

basis (pending distribution to holders or use for payment of permitted expenses) certain short-term, high-quality cash equivalents (as set out in the Wind Down Trust Agreement); instead the Wind Down Trust's activities will be limited to those reasonably necessary to, and consistent with, the Wind Down Trust's liquidating purpose and reasonably necessary to conserve, protect, and/or maximize the value of the Wind Down Trust Assets and provide for the orderly liquidation thereof. The Wind Down Trust Agreement shall contain appropriate provisions for monetizing the Wind Down Trust Assets in an orderly fashion, subject to the Wind Down Trustee's reasonable business judgment. The Wind Down Trustee, on behalf of the Wind Down Trust, will have discretion to enter into, consummate, settle, or otherwise resolve any transaction or dispute with respect to each of the Wind Down Trust Assets that have an economic value of less than \$5 million (in the Wind Down Trustee's good faith determination) as of the date of the consummation, settlement, or resolution of such transaction or dispute. The Wind Down Trustee will submit all other matters to the Bankruptcy Court for approval after notice and an opportunity for a hearing.

The Wind Down Trust will have an initial term of three years, which, subject to applicable law, may be extended by the Wind Down Trustee Filing a motion with the Bankruptcy Court prior to the expiration of the existing term and obtaining Bankruptcy Court approval of an extension for up to two years per request (subject, in each instance, to reasonable due consideration being given to implications of tax law and other applicable law of the proposed extension of the term of the Wind Down Trust). The Wind Down Trustee and the Litigation Trustee will cooperate and confer to ensure that the Wind Down Trust does not terminate prior to the Litigation Trust.

2. Transfer of Assets Into the Wind Down Trust.

Except as otherwise provided in this Plan or the Confirmation Order, on the Effective Date, the Wind Down Trust Assets shall be deemed transferred to the Wind Down Trust by the Debtors, such assets shall vest in the Wind Down Trust on such date, to be administered by the Wind Down Trustee in accordance with this Plan and the Wind Down Trust Agreement, and the Debtors and their Estates shall have no further interest with respect to the Wind Down Trust Assets. The Wind Down Trust Assets will vest in the Wind Down Trust free and clear of all Liens, Claims, Interests, encumbrances, etc. The act of transferring the Wind Down Trust Assets, as authorized by this Plan, shall not be construed to destroy or limit any such assets or rights or be construed as a waiver of any right, and such rights may be asserted by the Wind Down Trustee as if the asset or right was still held by the relevant Debtor.

The Wind Down Trustee shall have the authority to create additional sub-trusts within (or other subsidiary Entities under) the Wind Down Trust, which may have a separate legal existence, but which shall be considered sub-trusts (or other subsidiary Entities under, as applicable) of the Wind Down Trust.

3. Wind Down Trustee.

The Wind Down Trustee shall have the sole authority to make decisions and take action with respect to the Wind Down Trust in accordance with the terms of this Plan and the Wind Down Trust Agreement. The Wind Down Trustee shall be the successor to and representative of the Estates of the Debtors within the meaning of section 1123(b)(3)(B) of the Bankruptcy Code. Following the Effective Date, the Wind Down Trust and the Wind Down Trustee shall be deemed

a party in interest with standing to appear in the Chapter 11 Cases and object to any pleading Filed thereafter; *provided, however*, such standing and right to object does not alter the respective rights or responsibilities of the Wind Down Trustee or the Litigation Trustee under the Plan, the Wind Down Trust Agreement, or the Litigation Trust Agreement, alter any governing approval standard under applicable law, or otherwise limit the ability of any party with standing to respond to pleadings Filed, or objections raised, by the Wind Down Trustee. The powers, rights, and responsibilities of the Wind Down Trustee shall be specified in this Plan and the Wind Down Trust Agreement, and shall include, within the confines of the stated purpose of the Wind Down Trust, taking all appropriate actions to maximize the value of and monetize the Wind Down Trust Assets for the benefit of stakeholders, whether by accepting, preserving, receiving, collecting, administering, selling, liquidating, or transferring, as applicable, the Wind Down Trust Assets. All determinations with respect to the monetization of the Wind Down Trust Assets, including the Wind Down Trust's interests in Beneficient and FOXO, will be subject to the reasonable business judgment of the Wind Down Trustee, subject to compliance with any applicable lock-up agreement or securities law requirements and subject to the requirement that the Wind Down Trustee seek and obtain Bankruptcy Court approval of any transaction with an economic value of \$5 million or more, as set forth herein.

For the avoidance of doubt, the Wind Down Trustee may conduct sales or liquidations of Wind Down Trust Assets on any terms it deems reasonable, without further order of the Bankruptcy Court (except as provided herein). The Wind Down Trustee may also abandon any Wind Down Trust Assets that the Wind Down Trustee determines in its reasonable discretion to be of *de minimis* value or burdensome to the Wind Down Trust.

The Wind Down Trustee shall use the Wind Down Amount (and any subsequent monetization proceeds from the Wind Down Trust) to fund all expenses related to its duties under this Plan. The Wind Down Trustee, on behalf of the Wind Down Trust, may employ, without further order of the Bankruptcy Court, professionals (including professionals previously engaged in the Chapter 11 Cases), employees, or other independent contractors to assist in carrying out its duties this Plan, including the Wind Down Trust Agreement, and may compensate and reimburse the expenses of these professionals, employees, or other independent contractors based upon the nature of the work performed by such parties without further order of the Bankruptcy Court, subject to any limitations and procedures established by the Wind Down Trust Agreement.

4. Reports to Be Filed by the Wind Down Trust.

Following the Effective Date, and during the existence of the Wind Down Trust, the Wind Down Trust shall File with the Bankruptcy Court (and provide to any other party entitled to receive any such report pursuant to the Wind Down Trust Agreement), within 90 days after the end of each calendar year during the term of the Wind Down Trust, and within 45 days after the end of each calendar quarter during the term of the Wind Down Trust (other than the fourth quarter) and as soon as practicable upon termination of the Wind Down Trust, the Wind Down Trustee shall make available on its website, a written report including: (a) financial statements of the Wind Down Trust for such period, and, if the end of a calendar year, an unaudited report (which may be prepared by an independent certified public accountant employed by the Wind Down Trustee) reflecting the result of such agreed-upon procedures relating to the administration of the Wind Down Trust as proposed by the Wind Down Trustee; (b) a summary description of any action

taken by the Wind Down Trust which, in the judgment of the Wind Down Trustee, materially affects the Wind Down Trust; (c) a description of the progress of liquidating the Wind Down Trust Assets and making distributions to the holders of the New WDT Interests, which description shall include a written report detailing, among other things, the status of the equity interests in Beneficient and FOXO that are held by the Wind Down Trust, the status of Portfolio Co., the status of the Litigation Trust, the proceeds recovered as of the relevant date with respect to assets of the Wind Down Trust or any of the foregoing, and the distributions made by the Wind Down Trust as of the relevant date; and (d) any other material or significant information relating to the Wind Down Trust Assets and the administration of the Wind Down Trust deemed appropriate to be disclosed by the Wind Down Trustee. In addition, the Wind Down Trust shall provide unaudited financial statements to each holder of the New WDT Interests on a quarterly basis (which may be quarterly operating reports Filed with the Bankruptcy Court). The Wind Down Trustee may post any such report on a website maintained by or on behalf of the Wind Down Trustee and electronically File it with the Bankruptcy Court in lieu of actual notice to each holder of New WDT Interests (unless required by law).

Notwithstanding the foregoing, so long as the Wind Down Trust files periodic reports with the SEC pursuant to Section 13(a) or Section 15(d) of the Securities Exchange Act, the Wind Down Trustee shall be deemed to have satisfied its obligations set forth in the preceding paragraph by filing such periodic reports with the SEC, posting a copy of such reports on a website maintained by or on behalf of the Wind Down Trustee, and Filing a copy of such reports with the Bankruptcy Court.

5. 1940 Act Matters.

The implementation of this Plan and the Wind Down Transactions, *inter alia*, via the creation and administration of the Wind Down Trust, the Portfolio Co. and the Litigation Trust, is intended to enable the Wind Down Trust and the Debtors to fall within an exception to registration for companies that are dissolving, in accordance with Section 7 of the 1940 Act and the SEC staff's guidance regarding the same (the "Liquidating Company Exception"). In the event that the Wind Down Trustee determines in its sole and absolute discretion at any time that, notwithstanding such remedial actions undertaken or to be undertaken by the Wind Down Trust and/or the Debtors pursuant to the provisions of this Plan, the Wind Down Trust and the Debtors nonetheless are or will be unable to comply with or otherwise qualify for the Liquidating Company Exception or any other exception to or an exemption from registering under the 1940 Act, the Wind Down Trustee shall have the sole discretion and authority to develop another strategy to comply with or otherwise qualify under an exception to or exemption from such requirements of the 1940 Act. If it becomes necessary for 1940 Act compliance purposes to change the organization, operations and/or activities of the Wind Down Trust, the Wind Down Trustee will attempt to do so in a way to preserve the economic benefits of ownership of Wind Down Trust to the maximum extent possible.

B. U.S. Federal Income Tax Treatment and Reporting.

The Wind Down Trust is intended to qualify as a "grantor trust" as governed by sections 671 through section 679 of the Internal Revenue Code for U.S. federal income tax purposes with the New WDT Interest holders treated as grantors and owners of the Wind Down Trust. For all U.S. federal and applicable state and local income tax purposes, all parties (including,

without limitation, the Debtors, the Wind Down Trustee and the New WDT Interest holders) shall treat the Wind Down Trust, other than any portion thereof in respect of which a “disputed ownership fund” election has been made, as a liquidating trust under Treasury Regulation Section 301.7701-4 of which the New WDT Interest holders are the grantors and owners. Accordingly, for federal income tax purposes, it is intended that the New WDT Interest holders be treated as if they had received a transfer from the Debtors of an undivided interest in the Wind Down Trust Assets (to the extent of the value of their respective share in the applicable Assets) and then contributed such interests to the Wind Down Trust, and the New WDT Interest holders will be treated as the grantors and owners thereof. As soon as practicable after the Effective Date, the Wind Down Trustee shall make a good faith determination of the fair market value of the Wind Down Trust Assets as of the Effective Date. This valuation shall be used consistently by all parties (including the Debtors, the Wind Down Trustee and the New WDT Interest holders) for all U.S. federal income tax purposes.

The Wind Down Trust shall be established for the primary purpose of liquidating and distributing the assets transferred to it, in accordance with Treasury Regulation section 301.7701-4(d), with no objective to continue or engage in the conduct of a trade or business, except to the extent reasonably necessary to, and consistent with, the liquidating purpose of the Wind Down Trust. The Wind Down Trust shall not be deemed a successor-in-interest of the Debtors for any purpose other than as specifically set forth in this Plan or in the Wind Down Trust Agreement. The record holders of New WDT Interests shall be recorded and set forth in a register maintained by the Wind Down Trustee expressly for such purpose.

The Wind Down Trustee shall be responsible for filing all federal, state, and local tax returns for the Wind Down Trust and for the Debtors. The Wind Down Trustee shall be responsible for payment, out of the Wind Down Trust Assets, of any taxes imposed on the Wind Down Trust or the Wind Down Trust Assets. The Wind Down Trustee may request an expedited determination of taxes of the Wind Down Trust under section 505(b) of the Bankruptcy Code for all returns filed for, or on behalf of, the Wind Down Trust for all taxable periods through the dissolution of the Wind Down Trust.

The Wind Down Trust shall comply with all withholding and reporting requirements imposed by any federal, state, or local taxing authority, and all distributions made by the Wind Down Trust shall be subject to any such withholding and reporting requirements. The Wind Down Trustee shall be authorized to take any and all actions that may be necessary or appropriate to comply with such withholding and reporting requirements including, without limitation, requiring that, as a condition to the receipt of a distribution, the Holder of an Allowed Claim or Interest complete the appropriate IRS Form W-8 or IRS Form W-9. Notwithstanding any other provision of the Plan to the contrary, (1) each Holder of an Allowed Claim or Interest that is to receive a distribution pursuant to this Plan shall have the sole and exclusive responsibility for the satisfaction and payment of any tax obligations imposed on such Holder by any Governmental Unit, including income and other tax obligations, on account of such distribution (whether from the Debtors, the Wind Down Trust, or otherwise), and (2) no distribution shall be made to or on behalf of such Holder under the Plan unless and until such Holder has made arrangements satisfactory to the Wind Down Trustee to allow it to comply with its tax withholding and reporting requirements. Any property to be distributed by the Wind Down Trust shall, pending the implementation of such arrangements, be treated as an undeliverable distribution to be held by the Wind Down Trustee

until such time as the Wind Down Trustee is satisfied with the Holder's arrangements for any withholding tax obligations.

C. General Settlement of Claims and Interests.

As discussed further in the Disclosure Statement and as otherwise provided herein, pursuant to section 1123 of the Bankruptcy Code and Bankruptcy Rule 9019 and in consideration for the classification, distributions, releases, and other benefits provided under this Plan, upon the Effective Date, the provisions of this Plan shall constitute a good faith compromise and settlement of Claims and Interests and controversies resolved pursuant to the Plan. The Plan shall be deemed a motion to approve the good faith compromise and settlement of all such Claims, Interests, and controversies pursuant to Bankruptcy Rule 9019. Entry of the Confirmation Order shall constitute the Bankruptcy Court's approval of such compromise and settlement under section 1123 of the Bankruptcy Code and Bankruptcy Rule 9019, as well as a finding by the Bankruptcy Court that such settlement and compromise is fair, equitable, reasonable, and in the best interests of the Debtors and their Estates. Distributions made to Holders of Allowed Claims and Allowed Interests in any Class are intended to be and shall be final.

D. Wind Down Transactions.

On the Effective Date, the Wind Down Trustee will enter into such Wind Down Transactions as may be necessary or appropriate on each of the Debtors' or the Wind Down Debtors', as applicable, behalf to merge, dissolve, or otherwise terminate the corporate existence of each of the Debtors in accordance with the Wind Down Trust Agreement and the constituent documents of the Debtors without further order of the Bankruptcy Court; *provided*, that the Debtors and the Creditor Proponents may agree to dissolve the Debtors on a later date in order to promote efficiencies in the accrual of tax and other payment liabilities. The actions to effect the Wind Down Transactions may include: (1) the execution and delivery of appropriate agreements or other documents of transfer, merger, consolidation, disposition, liquidation, or dissolution containing terms that, among other things, are consistent with the terms of this Plan; (2) the execution and delivery of appropriate instruments of transfer, assignment, assumption, or delegation of any asset, property, right, liability, duty, or obligation on terms consistent with the terms of this Plan and that satisfy the requirements of applicable law; (3) the filing of appropriate certificates or articles of merger, consolidation, continuance, or dissolution, or similar instruments with the applicable governmental authorities; and (4) the taking of all other actions that the Wind Down Trustee determines, in its sole discretion, to be necessary or appropriate, including making other filings or recordings that may be required by applicable law in connection with the Wind Down Transactions.

On the Effective Date, subject in all respects (and after giving effect) to the treatment, distribution, and all other provisions of the Plan and the Confirmation Order, all property in each Estate, all Causes of Action, and any property acquired by any of the Debtors pursuant to this Plan shall vest in the Wind Down Debtors (and thereafter ultimately in the Wind Down Trust and/or the Litigation Trust, as applicable), free and clear of all Liens, Claims, charges, Causes of Action, or other encumbrances, except for those Liens, Claims, charges, or other encumbrances arising from or related to the Vida Exit Financing Facility. Each Debtor may be deemed dissolved in accordance with applicable law, without any further notice to or action, order, or approval of the

Bankruptcy Court or any other Entity. The Wind Down Trust shall be the issuer of the New WDT Interests as set forth herein.

On or before the Effective Date, the Policy Portfolio will be transferred free and clear of all Liens, Claims, charges, Causes of Action, or other encumbrances (except solely with respect to any such interests expressly granted in connection with the Vida Exit Financing Facility) to the fullest extent provided by the Bankruptcy Code to Portfolio Co., and the Policy Portfolio Equity Interests will be issued and transferred pursuant to the provisions of this Plan to the Wind Down Trust.

The Confirmation Order shall and shall be deemed to, pursuant to sections 363 and 1123 of the Bankruptcy Code, authorize, among other things, all actions as may be necessary or appropriate to effect any transaction described, contemplated, or necessary to effectuate this Plan. The Debtors, Wind Down Trust, Wind Down Trustee, Litigation Trust, and Litigation Trustee shall all use best efforts to cooperate with each other to ensure all necessary actions are taken as contemplated under this Plan.

E. Litigation Trust.

1. Litigation Trust Generally.

The Litigation Trust will be established on the Effective Date to retain and hold all Retained Causes of Action, the proceeds of which shall be deemed distributed to the Wind Down Trust for ultimate distribution by or at the direction of the Wind Down Trustee in accordance with the waterfall set forth in Article VI.C hereof. On the Effective Date, the Initial Litigation Trust Assets shall be deemed transferred to the Litigation Trust by the Wind Down Trust and will vest in the Litigation Trust free and clear of all Liens, Claims, interests, encumbrances, etc., with all reversionary and beneficial interests in the Litigation Trust to be held by the Wind Down Trust, subject to the waterfall set forth in Article VI.C hereof. The sole beneficiary of the Litigation Trust will be the Wind Down Trust (or the Wind Down Trustee on behalf of the Wind Down Trust, to the extent provided by applicable law), and all proceeds of the Litigation Trust distributed to the Wind Down Trust on account of such reversionary interest shall be for the sole purpose of distributions to the holders of the New WDT Interests issued by the Wind Down Trust; *provided, however*, such proceeds may be otherwise retained and used by the Wind Down Trust only with the consent of the Litigation Trustee or by order of the Bankruptcy Court. The act of transferring the Initial Litigation Trust Assets, as authorized by this Plan, shall not be construed to destroy or limit any such assets or rights or be construed as a waiver of any right, and such rights may be asserted by the Litigation Trust as if the asset or right was still held by the relevant Debtor. Notwithstanding anything to the contrary herein, the Litigation Trust may abandon to creditors or otherwise not accept any Retained Causes of Action that the Litigation Trustee believes, in good faith, have no value to the Litigation Trust; *provided*, that the Litigation Trust Agreement shall provide for the assignment by creditors to the Litigation Trust of any such Retained Causes of Action so abandoned to creditors.

For the avoidance of doubt, the Litigation Trustee, on behalf of the Litigation Trust, shall step into the shoes of the Debtors as it relates to either communications that occurred prior to, or documents prepared before, April 20, 2022 with respect to Debtors' right to assert attorney-client

privilege or any other privilege or immunity Debtor possesses, if any, and the Litigation Trustee shall be entitled to preserve, assert, access, or waive such privilege or immunity of the Debtors as it relates to such documents or communications. On the Effective Date, the Litigation Trustee shall have the power, right and responsibility to access or take possession of all books, files and records of the Debtors or Wind Down Debtors, as applicable, for purposes of carrying out the purpose of the Litigation Trust. At any time after the Effective Date, upon reasonable request of the Litigation Trustee, the Wind Down Trustee shall provide the Litigation Trustee with any of the Debtors' or the Wind Down Debtors' books, records, and files in the Wind Down Trust's or Wind Down Trustee's possession, custody, or control, and the Wind Down Trustee may, in good faith, provide such privileged information of the Debtors as is in the Wind Down Trustee's possession that relates to the evaluation and prosecution of the Retained Causes of Action; *provided*, that, notwithstanding the foregoing, the privilege of the Independent Directors, the DLP Independent Directors, and David F. Chavenson in his capacity as a former member of the Special Committee, in each case, is hereby recognized and shall remain in full force and effect and shall not be waived, nor shall any such privileged documents be turned over to any person or Entity without the consent of all Independent Directors or all DLP Independent Directors, as applicable. For the avoidance of doubt, neither the Independent Directors nor the DLP Independent Directors may waive Mr. Chavenson's personal privilege. The Wind Down Trustee shall use commercially reasonable efforts to assist the Litigation Trustee by providing additional information based on the books, files, and records in the Wind Down Trust's possession, provided that any such request for assistance is reasonable. Following the Effective Date, the Litigation Trust and the Litigation Trustee shall be deemed a party in interest with standing to appear in the Chapter 11 Cases and object to any pleadings Filed thereafter; *provided, however*, such standing and right to object does not alter the respective rights or responsibilities of the Litigation Trustee or the Wind Down Trustee under the Plan, the Wind Down Trust Agreement, or the Litigation Trust Agreement, alter any governing approval standard under applicable law, or otherwise limit the ability of any party with standing to respond to pleadings Filed, or objections raised, by the Litigation Trustee.

2. Litigation Trustee.

The Litigation Trustee shall be an independent, third-party fiduciary selected by the Bondholder Committee and identified in the Plan Supplement, and shall be compensated at market rates; *provided*, that, for the avoidance of doubt, the Litigation Trustee shall have no affiliation with any Bondholder Committee member and must not own any Public L Bonds, New WDT Interests, or other Interests in or Securities issued by any of the Debtors. The Litigation Trustee shall have the sole authority to make decisions and take action with respect to the Initial Litigation Trust Assets, the Retained Causes of Action, and the Litigation Trust Reconciliation Claims, and shall have a duty to maximize the value of the assets of the Litigation Trust in accordance with the Litigation Trust Agreement. The Litigation Trustee shall confer with the Wind Down Trustee with respect to the commencement of any litigation in respect of such assets, provided that the ultimate decision with respect to whether to commence any litigation shall be in the sole discretion of the Litigation Trustee. For the avoidance of doubt, in exercising such sole discretion, the Litigation Trustee shall consider and may take such actions in connection with the exercise of such sole discretion that promote the greatest recovery to the holders of the New WDT Interests. The Litigation Trustee shall seek Bankruptcy Court approval, after notice and an opportunity for a hearing, of (a) any settlements with respect to the Retained Causes of Action, and (b) any other transaction with respect to any assets of the Litigation Trust, in each case, that has an economic

value of \$5 million or more (in the Litigation Trustee's good faith determination) as of the date of such transaction.

The Litigation Trustee shall use the Initial Litigation Trust Funding Amount to fund all expenses related to its duties under this Plan and the Litigation Trust Agreement. Thereafter, the Litigation Trust and the Litigation Trustee may use proceeds from monetizing the Retained Causes of Action to fund the reasonable and customary out-of-pocket expenses incurred by the Litigation Trust and Litigation Trustee. Beginning on the Effective Date, the Litigation Trustee shall have customary powers, including the power to employ (without further order of the Bankruptcy Court) professionals (including professionals previously engaged in the Chapter 11 Cases), employees, or other independent contractors to assist in carrying out its duties under this Plan, including the Litigation Trust Agreement, and may compensate and reimburse the expenses of these professionals, employees, or other independent contractors based upon the nature of the work performed by such parties without further order of the Bankruptcy Court, subject to any limitations and procedures established by the Litigation Trust Agreement.

3. Reports to Be Filed by the Litigation Trust.

Following the Effective Date, and unless otherwise ordered by the Bankruptcy Court, and during the existence of the Litigation Trust, the Litigation Trust shall File with the Bankruptcy Court (and provide to any other party entitled to receive any such report pursuant to the Litigation Trust Agreement), within 90 days after the end of each calendar year during the term of the Litigation Trust, and within 45 days after the end of each calendar quarter during the term of the Litigation Trust (other than the fourth quarter), a quarterly report regarding the administration of property subject to its ownership and control pursuant to this Plan, receipts, distributions made by it, an update regarding the status of the Retained Causes of Action being prosecuted by the Litigation Trust, and a summary of all major activities during the period.

4. Termination of the Litigation Trust.

The initial term of the Litigation Trust shall be the lesser of: (a) three years; (b) the date all holders of New Series A1 WDT Interests and New Series A2 WDT Interests receive the full amount to which they are entitled to pursuant to this Plan; and (c) the date that all Retained Causes of Action have been fully resolved, as reasonably determined by the Litigation Trustee in its sole determination; *provided, however*, that, subject to applicable law, the Litigation Trustee may extend the term of the Litigation Trust solely in the event termination would otherwise occur under subsection (a) of this paragraph by Filing a motion with the Bankruptcy Court prior to the expiration of the initial term and obtaining court approval of such extension, with a maximum extension of two (2) years per request (subject, in each instance, to reasonable consideration being given to implications of tax law and other applicable law of a proposed extension of the term of the Litigation Trust). The Wind Down Trustee and the Litigation Trustee will cooperate and confer to ensure that the Wind Down Trust does not terminate prior to the Litigation Trust. For the avoidance of doubt, no later than the termination of the Litigation Trust, the Litigation Trustee shall transfer all of the Litigation Trust's assets, including any remaining Retained Causes of Action and net proceeds realized therefrom, to the Wind Down Trust. Notwithstanding the foregoing, and for the avoidance of doubt, nothing in this Plan (or the Plan Supplement, as applicable) shall prohibit the Litigation Trustee from making interim transfers of Cash realized by

the Litigation Trust to the Wind Down Trust for distribution to holders of New WDT Interests in accordance with this Plan.

F. Sources of Plan Consideration.

1. Vida DIP Financing Facility and Vida Exit Financing Facility.

On the Effective Date, the Debtors (or the Wind Down Debtors, as applicable) shall obtain the Vida Exit Financing Facility from an affiliate of Vida, the terms of which will be set forth in the Vida Exit Financing Facility Documents. The proceeds from the Vida Exit Financing Facility shall be used to refinance the Vida DIP Financing Facility. Confirmation of this Plan shall be deemed approval of the Vida Exit Financing Facility and the Vida Exit Financing Facility Documents, as applicable, and all transactions contemplated thereby, and all actions to be taken, undertakings to be made, and obligations to be incurred by the Portfolio Co. in connection therewith, including the payment of all fees, indemnities, expenses, and other payments provided for therein and authorization of the Portfolio Co. to enter into and execute the Vida Exit Financing Facility Documents and such other documents as may be required to effectuate the treatment afforded by the Vida Exit Financing Facility. The proceeds from the Vida DIP Financing Facility and Vida Exit Financing Facility, as applicable, shall be used to fund, among other things, the Portfolio Proceeds Amount, the Initial Litigation Trust Funding Amount, and the Wind Down Amount. For the avoidance of doubt, PJT shall not earn an additional Capital Raising Fee on account of the Vida Exit Facility Financing.

On the Effective Date, all of the Liens and security interests in respect of the assets of Portfolio Co. to be granted in accordance with the Vida Exit Financing Facility Documents: (a) shall be deemed to be granted; (b) shall be legal, binding, and enforceable Liens on, and security interests in, the collateral granted thereunder in accordance with the terms of the Vida Exit Financing Facility Documents; (c) shall be deemed automatically perfected, subject only to such Liens and security interests as may be permitted under the Vida Exit Financing Facility Documents; and (d) shall not be subject to recharacterization or equitable subordination for any purposes whatsoever and shall not constitute preferential transfers or fraudulent conveyances under the Bankruptcy Code or any applicable non-bankruptcy law. The Wind Down Debtors shall be authorized to make all filings and recordings, and to obtain all governmental approvals and consents necessary to establish and perfect all Liens and security interests under the Vida Exit Financing Facility Documents under the provisions of the applicable state, federal, or other law that would be applicable in the absence of this Plan and the Confirmation Order (it being understood that perfection shall occur automatically by virtue of the Confirmation Order and any such filings, recordings, approvals, and consents shall not be required to perfect such Liens and security interests).

2. New WDT Interests.

On the Effective Date, the Wind Down Trust shall issue the New WDT Interests directly or indirectly to Holders of Claims and Interests to the extent provided in this Plan as follows:

- (a) New Series A1 WDT Interests: The Wind Down Trust shall issue the New Series A1 WDT Interests in an amount equal to the outstanding amount of

the Allowed Class 3 Bond Claims (less any LBM Subordinated Claims) after taking into consideration the Cash payment(s) made on account of such Claims on the Effective Date in connection with Article III.B.3 of this Plan. The New Series A1 WDT Interests shall be satisfied, redeemed, and cancelled in full in accordance with the terms and provisions of the New WDT Documents prior to any distributions on account of any subsequent series of New WDT Interests. Any New Series A1 WDT Interests, if any, issued to the Indenture Trustee on account of any outstanding Indenture Fee and Expense Claims shall be expressly senior in all respects to any New Series A1 WDT Interests issued to other Holders on account of their respective Allowed Class 3 Bond Claims.

- (b) New Series A2 WDT Interests: The Wind Down Trust shall issue the New Series A2 WDT Interests in an amount equal to the aggregate amount of Allowed LBM Subordinated Claims in Class 3. The New Series A2 WDT Interests shall be satisfied, redeemed, and cancelled in full in accordance with the terms and provisions of the New WDT Documents prior to any distributions on account of any subsequent series of New WDT Interests. The New Series A2 WDT Interests shall not receive any distributions prior to the satisfaction, redemption, and cancellation of the New Series A1 WDT Interests
- (c) New Series B WDT Interests: The Wind Down Trust shall issue the New Series B WDT Interests in an amount equal to the aggregate amount of Class 4(a) Allowed General Unsecured Claims. The New Series B WDT Interests shall be satisfied, redeemed, and cancelled in full in accordance with the terms and provisions of the New WDT Documents prior to any distributions on account of any subsequent series of New WDT Interests. The New Series B WDT Interests shall not receive any distributions prior to the satisfaction, redemption, and cancellation of the New Series A1 WDT Interests and the New Series A2 WDT Interests.
- (d) New Series C WDT Interests: The Wind Down Trust shall issue New Series C WDT Interests in an amount equal to the aggregate amount of Allowed Class 8 Series 1 Preferred Interests (based on each Series 1 Preferred Interest having an initial stated value of \$1,000.00 per share). The New Series C WDT Interests shall receive distributions on a *pari passu* basis with the New Series D WDT Interests, and the New Series C WDT Interests shall be satisfied, redeemed, and cancelled in full in accordance with the terms and provisions of the New WDT Documents prior to any distributions on account of the New Series E WDT Interests. The New Series C WDT Interests shall not receive any distributions prior to the satisfaction, redemption, and cancellation of the New Series A1 WDT Interests, the New Series A2 WDT Interests, and the New Series B WDT Interests.
- (e) New Series D WDT Interests: The Wind Down Trust shall issue the New Series D WDT Interests in an amount equal to the aggregate amount of

Allowed Class 9 Series 2 Preferred Interests (based on each Series 2 Preferred Interest having an initial stated value of \$1,000.00 per share). The New Series D WDT Interests shall receive distributions on a *pari passu* basis with the New Series C WDT Interests, and the New Series D WDT Interests shall be satisfied, redeemed, and cancelled in full in accordance with the terms and provisions of the New WDT Documents prior to any distributions on account of the New Series E WDT Interests. The New Series D WDT Interests shall not receive any distributions prior to the satisfaction, redemption and cancellation of the New Series A1 WDT Interests, the New Series A2 WDT Interests, and the New Series B WDT Interests.

- (f) New Series E WDT Interests: The Wind Down Trust shall issue the New Series E WDT Interests in a number equal to the aggregate number of Allowed Class 10 Common Stock. Holders of New Series E WDT Interests shall receive distributions as authorized by the Wind Down Trustee; *provided*, that (a) holders of New Series E WDT Interests shall not be entitled to receive any distributions until all other series of New WDT Interests have been satisfied, cancelled, and redeemed in accordance with the terms and provisions of the New WDT Documents, and (b) nothing herein requires the Wind Down Trustee to authorize any distributions to holders of New Series E WDT Interests.

The issuance of the New WDT Interests shall be authorized without the need for any further corporate action and without any further action by any party. The terms of the New WDT Interests shall be governed by the New WDT Documents, the terms of which shall be set forth in the Plan Supplement.

All of the New WDT Interests issued pursuant to this Plan shall be duly authorized, validly issued, fully paid, and non-assessable. Each distribution and issuance referred to in Article III hereof shall be governed by the terms and conditions set forth in this Plan applicable to such distribution or issuance, and by the terms and conditions relating to such distribution or issuance, which terms and conditions shall bind each Entity receiving such distribution or issuance.

G. Redemption of New WDT Interests.

Each Cash distribution from or at the direction of the Wind Down Trustee on behalf of the Wind Down Trust (including any Cash distributions consisting of any proceeds realized from the prosecution and/or settlement of the Retained Causes of Action by the Litigation Trust) on account of any New WDT Interests shall be deemed to constitute the redemption, satisfaction, and cancellation of such New WDT Interests in an amount equal to such Cash distribution. Cash recoveries from the Debtors' Estates, including the Wind Down Trust, or the Litigation Trust shall be deemed applied on a dollar-for-dollar basis as a redemption of, and in reduction of, the amount of such New WDT Interests.

Holders of the New WDT Interests cannot recover more than the full amounts owed on account of such New WDT Interests unless such recovery is: (1) permissible under applicable

law; and (2) from third-party sources other than the Debtors, the Wind Down Trust, or the Litigation Trust, as provided for under this Plan.

H. Priority of Cash Distributions to Holders of New WDT Interests.

The Wind Down Trustee shall make an initial Cash distribution to holders of New WDT Interests consisting of the Net Cash Proceeds, if any, within 60 days after the Effective Date, and on a semi-annual basis thereafter to the extent of any Net Cash Proceeds; *provided*, that the Wind Down Trustee may, in its sole discretion, make additional special distributions to the extent of any Net Cash Proceeds available; *provided, further*, that, in each instance, no distribution shall be required unless the Net Cash Proceeds then held by the Wind Down Trustee is equal to or greater than the Minimum Distribution Amount.

Any Cash distributions, including any distributions consisting of the Net Cash Proceeds realized from the monetization of the Wind Down Trust Assets, including the interests in Beneficial or FOXO, made by the Wind Down Trust to holders of New WDT Interests, after establishment of appropriate reserves for payment of Wind Down Trust expenses to the extent provided in the Wind Down Budget or the Wind Down Trust Agreement (or approved by separate order of the Bankruptcy Court), shall be distributed in the following order of priority (with no distributions to any junior class until all payments are made to senior classes in full):

1. the New Series A1 WDT Interests (if any) issued to the Indenture Trustee in connection with the Indenture Fee and Expense Claims in Class 3, up to the outstanding amount of such Claims;
2. all other New Series A1 WDT Interests, up to the Allowed outstanding prepetition amount of Allowed Bondholder Claims in Class 3;
3. the New Series A2 WDT Interests, up to the Allowed outstanding prepetition amount of Allowed LBM Subordinated Claims in Class 3;
4. the New Series A1 WDT Interests and the New Series A2 WDT Interests, up to the amount of interest accrued on such New Series A1 WDT Interests and New Series A2 WDT Interests, which interest shall accrue under the New WDT Documents from April 20, 2022 calculated at a 9% per annum interest rate;
5. the New Series B WDT Interests, up to the Allowed prepetition outstanding amount of Class 4(a) Allowed General Unsecured Claims;
6. the New Series B WDT Interests, up to the Allowed postpetition balance of Class 4(a) Allowed General Unsecured Claims, comprised of interest on the Allowed prepetition amount of such Claims starting from April 20, 2022 calculated at the Federal Judgment Rate;
7. the New Series C WDT Interests and the New Series D WDT Interests, on a pro rata *pari passu* basis, per liquidation rights under the New WDT Documents and applicable law, up to the Allowed aggregate outstanding amount of the Class 8 Series 1 Preferred Interests and Class 9 Series 2 Preferred Interests (based on each

Series 1 Preferred Interest and each Series 2 Preferred Interest having an initial stated value of \$1,000.00 per share); and

8. the New Series E WDT Interests.

I. LBM Settlement.

Unless LBM withdraws from the LBM Settlement as provided in the following paragraphs of this Article IV.I, on the Effective Date, the LBM L Bond Claims shall be: (1) Allowed in full with the LBM Subordinated Claims classified as Allowed Class 3 Bond Claims to be treated as provided in Article III.B.3.(b).(iii) of this Plan, and the remainder of the LBM L Bond Claims as Allowed Bondholder Claims in Class 3 to be treated as provided in Article III.B.3.(b).(i) and (ii) of this Plan; and (2) the LBM Released Claims shall be fully and finally released against all of the LBM Released Parties.

In the event that the Debtors reach a settlement with Beneficient, LBM shall have the right to withdraw from the agreements with respect to the allowance and treatment of the LBM L Bond Claims, and the right to releases, each as described and provided in the preceding paragraph by Filing a written notice on the docket within three Business Days of a motion to approve such Beneficient settlement being Filed on the docket. In event of such a timely-Filed withdrawal: (a) all agreements memorialized above shall be deemed withdrawn, including, but not limited to, all subordination agreements and all Claim allowances; (b) all claims, offsets, credits, objections and challenges of any kind to claims proposed to be settled above are reinstated in their entirety and shall be transferred to the Litigation Trust on the Effective Date as Litigation Trust Reconciliation Claims; and (c) the LBM L Bond Claims will be deemed Disputed Class 3 Claims without further action, Filing, or other request by the Debtors or the Bondholder Committee until the Claim Objection Bar Date at which time the LBM L Bond Claims shall be Allowed; *provided*, that such LBM L Bond Claims shall be considered Allowed only if and to the extent that no objection or other challenge in respect of the LBM L Bond Claims has been Filed on or prior to the Claim Objection Bar Date or such timely objection or other challenge has been Filed and the Claim thereafter has been Allowed by a Final Order. In any case, the LBM L Bond Claims shall be fully Allowed for voting purposes, and LBM agrees to and shall support and shall be deemed to accept this Plan on account of the LBM L Bond Claims and be a Creditor Proponent consistent with the Mediation Agreement (it being understood that any settlement with Beneficient shall be set forth in an order approving any such settlement under Bankruptcy Rule 9019 and that LBM's only rights with respect to a settlement with Beneficient are (i) withdrawing from the settlement set forth in this Article IV.I and/or (ii) objecting to such settlement with Beneficient).

In the event of such a withdrawal and subject to the timely Filing of an objection or other challenge to the LBM L Bond Claims: (i) the New Series A1 WDT Interests shall not be issued on account of any portion of the LBM L Bond Claims on the Effective Date; (ii) pending the resolution of such timely-Filed disputes, the Wind Down Trustee shall not make any distributions of any kind on account of the LBM L Bond Claims, but shall maintain appropriate reserves for the LBM L Bond Claims in any distribution on account of New Series A1 WDT Interests made during that period, in a manner the Wind Down Trustee solely determines is reasonable; (iii) no New Series A2 WDT Interests shall be issued on the Effective Date; *provided, however*, that prior to the Allowance (if any) of the LBM L Bond Claims, such class of New WDT Interests, as

applicable, shall not be deemed vacant; and (iv) upon the final resolution of any timely-Filed objection or other challenge of any kind through the entry of a Final Order of the Bankruptcy Court, the Wind Down Trustee shall cause to be issued or cancelled, as applicable, the New Series A1 WDT Interests and New Series A2 WDT Interests (as necessary), or any other class of New WDT Interests, as appropriate, so that LBM receives the New Series A1 WDT Interests in the Allowed, non-subordinated amount of its LBM L Bond Claims, if any, and the New Series A2 WDT Interests in the subordinated amount, if any, of its Allowed Class 3 LBM Subordinated Claims, or any other class of New WDT Interests, as appropriate, as determined by such Final Order, and the Wind Down Trustee shall thereafter promptly distribute (or redistribute) any such maintained reserve amounts, as appropriate, consistent with the determination in such Final Order. Notwithstanding any other provision of this Plan to the contrary: (x) the Debtors or the Wind Down Trustee, as the case may be, may modify the Plan to provide for treatment of the LBM L Bond Claims consistent with the determination in any such Final Order in subsection (iv) above; and (y) any conflict between the provisions of this subsection and any other provision of this Plan shall be governed by the provisions of this subsection.

J. Exemption from Registration Requirements.

The Debtors intend that the Wind Down Trust will be organized in compliance with applicable law such that the New WDT Interests will not be deemed to be or treated as securities under applicable law. As a result, the Debtors do not believe that registration under the Securities Act and applicable state law in connection with the issuance and distribution of the New WDT Interests or an exemption from such registration requirements is required. However, to the extent that the New WDT Interests issued under this Plan are deemed securities, the issuance and distribution thereof would qualify for issuance without registration under the Securities Act or any similar federal, state, or local law pursuant to section 1145 of the Bankruptcy Code. To the extent that the issuance and distribution of the New WDT Interests issued under this Plan is completed pursuant to section 1145 of the Bankruptcy Code, such New WDT Interests would be exempt from, among other things, the registration requirements of Section 5 of the Securities Act and any other applicable U.S. state or local law requiring registration prior to the offering, issuance, distribution, or sale of securities. Pursuant to section 1145 of the Bankruptcy Code, any such New WDT Interests issued under this Plan: (1) would not be “restricted securities” as defined in Rule 144(a)(3) under the Securities Act; and (2) as a matter of federal securities law, would be freely tradable and transferrable under the federal securities laws by any holder thereof that (a) is not an “affiliate” of the Wind Down Trust, as defined in Rule 144(a)(1) under the Securities Act, (b) has not been such an “affiliate” within three months of such transfer, (c) has not acquired the New WDT Interests from an “affiliate” within one year of such transfer, and (d) is not an Entity that is an “underwriter” as defined in section 1145(b) of the Bankruptcy Code.

Notwithstanding the forgoing or anything to the contrary in this Plan, the New WDT Documents will provide that the New WDT Interests may not be transferred, sold, pledged or otherwise disposed of, or offered for sale, except for transfers by will, intestacy or operation of law. The Wind Down Trust will be organized in compliance with applicable law such that the New WDT Interests will not be treated as securities and under such facts the Debtors do not believe that registration under the Securities Act and applicable state law in connection with the issuance and distribution of the New WDT Interests or an exemption from such registration requirements would be required. The Wind Down Trustee will be permitted to determine in its sole discretion

to take such actions that are necessary or reasonably advisable (including, without limitation, completing a registration under the Securities Exchange Act) to modify or remove any contractual restrictions on transferability of the New WDT Interests, with any such determination by the Wind Down Trustee, and all costs associated therewith, to be deemed a determination with respect to the monetization of the Wind Down Trust Assets subject to Bankruptcy Court approval to the extent provided pursuant to Article IV.A.3 hereof and to be evaluated solely under a reasonable business judgment standard.

To the extent that the New WDT Interests are rendered transferable as described in the preceding paragraph, DTC shall be required to accept and conclusively rely upon this Plan or the Confirmation Order in lieu of a legal opinion regarding whether such securities are exempt from registration and/or eligible for DTC book-entry delivery, settlement, and depository services. Notwithstanding anything to the contrary in this Plan, no legal opinion regarding the offering, issuance, and distribution of any securities contemplated by this Plan, including, for the avoidance of doubt, whether the New WDT Interests are exempt from registration and/or eligible for DTC book-entry delivery, settlement, and depository services shall be required.

K. Section 1146(a) Exemption.

To the fullest extent permitted by section 1146(a) of the Bankruptcy Code, any transfers (whether from a Debtor to the Wind Down Trust, the Litigation Trust, or to any other from any other party, as the case may be) of property under this Plan or pursuant to: (1) the issuance, Reinstatement, distribution, transfer, or exchange of any debt, equity interest, or other interest in the Debtors or the Wind Down Trust; (2) the transactions, including the Wind Down Transactions, described herein; (3) the creation, modification, consolidation, termination, refinancing, and/or recording of any mortgage, deed of trust, or other security interest, or the securing of additional indebtedness by such other means; (4) the making, assignment, or recording or any lease or sublease; (5) the grant of collateral as security for any or all of the Debtors or Wind Down Debtors' obligations under or in connection with the Vida Exit Financing Facility; or (6) the making, delivery, or recording of any deed or other instrument of transfer under, in furtherance of, or in connection with, this Plan, including any deeds, bills of sale, assignments, or other instrument of transfer executed in connection with any transaction arising out of, contemplated by, or in any way related to this Plan, shall not be subject to any document recording tax, stamp tax, conveyance fee, intangibles or similar tax, mortgage tax, stamp act, real estate transfer tax, personal property transfer tax, mortgage recording tax, Uniform Commercial Code filing or recording fee, regulatory filing or recording fee, or other similar tax or governmental assessment, and upon entry of the Confirmation Order, the appropriate state or local governmental officials or agents shall forego the collection of any such tax, recordation fee or governmental assessment and accept for filing and recordation of any of the foregoing instruments or other documents without the payment of any such tax, recordation fee, or governmental assessment. All filing or recording officers (or any other person with authority over any of the foregoing), wherever located and by whomever appointed, shall comply with the requirements of section 1146(c) of the Bankruptcy Code, shall forego the collection of any such tax, recordation fee or governmental assessment, and shall accept for filing and recordation any of the foregoing instruments or other documents without the payment of any such tax, recordation fee, or governmental assessment.

L. Cancellation of Securities and Agreements.

On the Effective Date, except to the extent otherwise provided in the Plan, the Confirmation Order, or any agreement, instrument or other document entered into in connection with the Plan, all prepetition credit agreements, security agreements, intercreditor agreements, notes, instruments, Certificates, and other documents evidencing, or in any way related to, Claims or Interests (including the Indenture Documents) shall be deemed cancelled and surrendered without further action or approval of the Bankruptcy Court or any Holder of a Claim or Interest, and the obligations of the Debtors thereunder or in any way related thereto shall be released, settled, and compromised, and the Indenture Trustee, and its agents, successors and assigns shall each be automatically and fully released and discharged of and from all duties and obligations thereunder; *provided*, that, notwithstanding Confirmation or the occurrence of the Effective Date, any such prepetition credit agreement, security agreement, intercreditor agreement, or other document that governs the rights of the Holder of a Claim or Interest (including the Indenture Documents) shall continue in effect solely for purposes of: (1) enabling Holders of Allowed Claims and Allowed Interests to receive distributions under the Plan as provided herein; (2) governing the contractual rights and obligations among creditor parties (including, without limitation, indemnification, expense reimbursement, and distribution provisions); (3) allowing the Indenture Trustee to exercise its Indenture Trustee Charging Lien against distributions to Holders of Claims under the Indenture Documents, as applicable; (4) preserving all rights, remedies, indemnities, powers, and protections, including rights of enforcement, of the Indenture Trustee against any person or entity (including, without limitation, with respect to any indemnification or contribution from Holders of Bond Claims under the Indenture), other than the Debtors or the Wind Down Debtors (except as otherwise provided in this Plan) or any exculpations of the Indenture Trustee, to the extent that such rights, remedies, indemnities, powers, or protections exist pursuant to the terms of the Indenture Documents and applicable law; (5) permitting the Indenture Trustee to appear in the Chapter 11 Cases or in any proceeding in the Bankruptcy Court or any other court, including to enforce the obligations owed to it under this Plan and to enforce any obligations owed to Holders of Bond Claims under this Plan in accordance with the applicable Indenture Documents; and (6) permitting the Indenture Trustee to perform any functions that are necessary to effectuate the foregoing; *provided, further*, that, except to the extent otherwise provided in this Plan, the Confirmation Order, or any agreement, instrument or other document entered into in connection with this Plan, the survival of any prepetition credit agreements, security agreements, intercreditor agreements, rights, notes, instruments, Certificates, and other documents evidencing Claims or Interests shall not give rise to any Claims against the Debtors, the Wind Down Debtors, or the Wind Down Trustee or their respective officers, managers, directors, representatives, and agents for fees, expenses, or otherwise. As a condition precedent to receiving any distribution on account of its Allowed Class 3 Bond Claim, each Holder of an Allowed Class 3 Bond Claim shall be deemed to have surrendered its respective bonds and other documentation underlying its Class 3 Bond Claims, and all such surrendered bonds and other documentation shall be deemed to be cancelled pursuant to this section, except to the extent otherwise provided herein.

M. Corporate Action.

Upon the Effective Date, or as soon thereafter as is reasonably practicable, and without the need for any further corporate action or other action by Holders of Claims or Interests, all corporate actions contemplated under this Plan shall be deemed authorized and approved in all respects,

without the need for any approvals, authorizations, or consents, except for those expressly required pursuant to this Plan, or any further notice to or action, order, or approval of the Bankruptcy Court, including, as applicable: (1) selection and appointment of the Wind Down Trustee; (2) the creation of and vesting in the Wind Down Trust, including the adoption, execution, acknowledgement, delivery, recording, and/or filing (as applicable) of the Wind Down Trust Agreement; (3) the authorization, issuance, delivery, and distribution of the New WDT Interests issued pursuant to this Plan; (4) the execution of and entry into the Vida Exit Financing Facility Documents; (5) the creation of and vesting in the Litigation Trust; and (6) all other actions contemplated by this Plan (whether to occur before, on, or after the Effective Date).

Upon the Effective Date, all matters provided for in this Plan involving the corporate or company structure of the Debtors, the Wind Down Debtors, or the Wind Down Trust and any corporate or company action required by the Debtors or the Wind Down Trustee in connection with this Plan, including the transfer of the Policy Portfolio to Portfolio Co. and the issuance of the Policy Portfolio Equity Interests, shall be deemed to have occurred and shall be in effect, without any requirement or further action by the security holders, directors, managers, or officers of the Debtors, the Wind Down Debtors, or the Wind Down Trustee. On or prior to the Effective Date (as applicable), the appropriate officers of the Debtors, the Wind Down Trustee, or the Litigation Trustee (as applicable) shall be authorized and (as applicable) directed to issue, execute, and deliver the agreements, documents, securities, and instruments contemplated under this Plan (or necessary or desirable to effect the transactions contemplated under this Plan) in the name of and on behalf of the Wind Down Debtors, the Wind Down Trust, and/or the Litigation Trust including the New WDT Interests, the Wind Down Trust Agreement, the Litigation Trust Agreement, the Vida Exit Financing Facility Documents, and any and all other agreements, documents, securities, and instruments relating to the foregoing. The authorizations and approvals contemplated by this Article IV.M shall be effective notwithstanding any requirements under non-bankruptcy law.

N. Dissolution and Board of Directors.

As of the Effective Date, the term of the current members of the board of directors of the Debtors, including the Independent Directors and the DLP Independent Directors, shall expire, the Investigations Committee, the Special Committee and each conflicts committee at each DLP Entity shall cease to exist; *provided, that*, following the Effective Date, the Independent Directors and the DLP Independent Directors shall retain authority solely with respect to matters related to Accrued Professional Compensation Claims by Professionals acting at their authority and direction in accordance with the terms of the Plan. Any Causes of Action that have been commenced by the Investigations Committee, and are not released pursuant to Article VIII.C hereof, shall be included in the Retained Causes of Action and transferred to the Litigation Trust on the Effective Date. Notwithstanding any other language to the contrary herein, solely with respect to communications that occurred on or after April 20, 2022, each of the Independent Directors in their capacity as such, the DLP Independent Directors in their capacity as such, and David F. Chavenson in his capacity as a former member of the Special Committee, shall not have any of their respective privileged and confidential documents, communications or information transferred (or deemed transferred) to the Wind Down Debtors, the Wind Down Trustee, the Wind Down Trust, the Litigation Trust, the Litigation Trustee, any liquidation trust that may be formed or its trustee or board, or any related party of any of the foregoing Entities, or any other person or Entity,

without the prior written consent of the Independent Directors or the DLP Independent Directors, as applicable. For the avoidance of doubt, neither the Independent Directors nor the DLP Independent Directors may waive Mr. Chavenson's personal privilege.

As of the Effective Date, the Wind Down Trustee shall act as the Wind Down Debtors' sole officer, director, and manager, as applicable, with respect to the Wind Down Debtors' affairs, other than with respect to the Litigation Trust or Portfolio Co., as set forth herein. On the Effective Date, any remaining officers, managers, or managing members of any Debtor shall be dismissed without further action required on the part of any such Debtor or any other party.

O. Effectuating Documents; Further Transactions.

On and after the Effective Date, the Wind Down Trust and the Wind Down Trustee are authorized to and may issue, execute, deliver, file, or record such contracts, securities, instruments, releases, and other agreements or documents and take such actions as may be necessary to effectuate, implement, and further evidence the terms and conditions of the Plan and the New WDT Interests issued pursuant to this Plan, without the need for any approvals, authorizations, or consents, except for those expressly set forth in and required pursuant to this Plan. On and after the Effective Date, except as otherwise provided herein, the Wind Down Trust and the Litigation Trust, as applicable, may engage in activities as set forth herein and may use, acquire, or dispose of property and pursue, compromise, or settle any Claims, Interests, or Retained Causes of Action without supervision or approval by the Bankruptcy Court (except as otherwise provided herein) and free of any restrictions of the Bankruptcy Code or Bankruptcy Rules.

P. Vesting of Assets.

Except as otherwise provided herein, or in any agreement, instrument, or other document incorporated in this Plan, on the Effective Date, all property in each Debtor's Estate, all claims, rights, defenses, and Retained Causes of Action, and any property acquired by the Wind Down Trust, Litigation Trust, or Wind Down Debtors under or in connection with this Plan shall vest in the Wind Down Trust, Litigation Trust, or each of the Wind Down Debtors, as applicable, free and clear of all Liens, Claims, charges, or other encumbrances (except for those Liens, Claims, charges, or other encumbrances arising from or related to the Vida Exit Financing Facility), for subsequent or deemed transfer by each such party, pursuant to the provisions of this Plan.

Q. Preservation of Causes of Action.

In accordance with section 1123(b) of the Bankruptcy Code, the Litigation Trust shall retain and may enforce all rights to commence and pursue, as appropriate, any and all Causes of Action, whether arising before or after the applicable Petition Date, including without limitation any Causes of Action specifically enumerated in the schedule of Retained Causes of Action included in the Plan Supplement and the Litigation Trust's right to commence, prosecute, or settle such Causes of Action shall be preserved notwithstanding the occurrence of the Effective Date. For the avoidance of doubt, Causes of Action that are or were settled, released, waived, exculpated, or transferred pursuant to the Plan or any order of the Bankruptcy Court entered in these Chapter 11 Cases (as the same may be amended, modified, or supplemented from time to time by the Debtors), shall not constitute Retained Causes of Action.

The Litigation Trust may pursue such Retained Causes of Action, as appropriate and in accordance with the Litigation Trust Agreement. **No Entity may rely on the absence of a specific reference in this Plan, the Litigation Trust Agreement, the Plan Supplement, or the Disclosure Statement to any Cause of Action against it as any indication that the Debtors, the Wind Down Debtors, the Wind Down Trust, or the Litigation Trust, as applicable, will not pursue any and all available Causes of Action against it. The Debtors, the Wind Down Debtors, the Wind Down Trust, or the Litigation Trust, as applicable, expressly reserve all rights to prosecute any and all Causes of Action against any Entity, except as otherwise expressly provided in this Plan, including Article VIII of this Plan.** Unless any Causes of Action against an Entity is expressly waived, relinquished, exculpated, released, compromised, or settled in this Plan or a Bankruptcy Court order, the Wind Down Debtors expressly reserve all Causes of Action for later adjudication and, therefore, no preclusion doctrine, including the doctrines of res judicata, collateral estoppel, issue preclusion, claim preclusion, estoppel (judicial, equitable, or otherwise), or laches shall apply to such Causes of Action upon, after, or as a consequence of the Confirmation of this Plan.

The Litigation Trust reserves and shall retain such Causes of Action notwithstanding the rejection or repudiation of any Executory Contract or Unexpired Lease during the Chapter 11 Cases or pursuant to this Plan. In accordance with section 1123(b)(3) of the Bankruptcy Code, any Causes of Action that a Debtor may hold against any Entity shall be deemed transferred to and vest in the Litigation Trust except as otherwise expressly provided in this Plan. The Litigation Trust, through its authorized agents or representatives, shall retain and may exclusively enforce any and all Retained Causes of Action. The Litigation Trust shall have the exclusive right, authority, and discretion to determine and to initiate, file, prosecute, enforce, abandon, settle, compromise, release, withdraw, or litigate to judgement any such Causes of Action and to decline to do any of the foregoing without the consent or approval of any third party or further notice to or action, order, or approval of the Bankruptcy Court; *provided*, that the entry into any settlement of any Claim, Cause of Action, or other dispute with an economic value of \$5 million or more (in the Litigation Trustee's good faith determination) as of the date of the consummation, settlement, or resolution of such transaction or dispute shall require the approval of the Bankruptcy Court after notice and an opportunity for a hearing.

Notwithstanding anything contained herein to the contrary (including the Debtor Release described in Article VIII.C hereof), to the extent the Debtors are releasing or have previously released certain claims and Causes of Action against a party, including pursuant to this Plan or any Final Order of the Bankruptcy Court entered in these Chapter 11 Cases on or before the Effective Date, nothing in this Plan shall be construed to revive such released claims and Causes of Action against such party or be construed to impair or otherwise limit the releases provided thereunder.

R. Continuing Effectiveness of Final Orders.

Payment authorization granted to the Debtors under any prior Final Order entered by the Bankruptcy Court shall continue in effect after the Effective Date. Accordingly, the Debtors, the Wind Down Debtors, the Wind Down Trustee, and the Litigation Trustee, as applicable, may pay or otherwise satisfy any Claim to the extent permitted by, and subject to, the applicable Final Order without regard to the treatment that would otherwise be applicable to such Claim under this Plan.

S. D&O Liability Insurance Policies.

Notwithstanding anything in this Plan to the contrary, all of the Debtors' D&O Liability Insurance Policies and any agreements, documents, or instruments relating thereto, are treated as and deemed to be Executory Contracts under this Plan. On the Effective Date, pursuant to section 365(a) of the Bankruptcy Code, the Debtors shall be deemed to have assumed all D&O Liability Insurance Policies and any agreements, documents, and instruments related thereto (including tail coverage liability insurance). Entry of the Confirmation Order will constitute the Bankruptcy Court's approval of the Debtors' assumption of all such insurance policies, including the D&O Liability Insurance Policies. After the Effective Date, the Wind Down Debtors and the Litigation Trust, as applicable, shall not terminate or otherwise reduce, modify, or restrict in any way the coverage under any D&O Liability Insurance Policy (including such tail coverage liability insurance) in effect as of the Effective Date, including with respect to conduct occurring on or prior to April 20, 2022, and all members, managers, directors, and officers of the Debtors who served in such capacity at any time prior to the Effective Date of the Plan and who are covered by any such policy shall be entitled to the full benefits of any such policy for the full term of such policy regardless of whether such members, managers, directors, and/or officers remain in such positions after the Effective Date. Without limiting the generality of the other provisions of this Plan, and following such assumption, all right, title, and interest of the Debtors (and of the Wind Down Debtors and the Litigation Trust, as applicable) in and to any D&O Liability Insurance Policy (including any such tail coverage liability insurance) in effect as of the Effective Date covering claims relating to conduct occurring on or prior to April 20, 2022 shall be deemed assigned and fully transferred on the Effective Date to the Litigation Trust and shall constitute Initial Litigation Trust Assets for all purposes.

T. Payment of Certain Fees.

On the Effective Date, the Debtors or the Wind Down Debtors, as applicable, shall pay in full in Cash the Indenture Fee and Expense Claim incurred at any time prior to and through the Effective Date from the Portfolio Proceeds up to the amount: (1) agreed to by the Debtors, the Indenture Trustee, and the Creditor Proponents, without the need for the Indenture Trustee to File any Proof of Claim, request for payment of Administrative Claim, fee application, itemized time details, or any other pleading or document in the Chapter 11 Cases, and without reduction to recoveries on account of any of the Allowed Bond Claims; or (2) as determined by the Bankruptcy Court, in the event that the amount is not resolved pursuant to mediation. From and after the Effective Date, the Wind Down Debtors shall pay in full in Cash the Indenture Fee and Expense Claim incurred in connection with distributions, communications to Holders, responses to Holder inquiries, or the cancellation and discharge of the Indenture Documents, without any requirement for the Indenture Trustee to File any Proof of Claim, request for payment of Administrative Claim, fee application, or any other pleading or documents in the Chapter 11 Cases, or to provide itemized time details, and without reduction to recoveries on account of any of the Allowed Bond Claims. In the event the Portfolio Proceeds are insufficient to provide such payment (after taking into account the full amounts of the Initial Litigation Trust Funding Amount and the Wind Down Amount), the Indenture Trustee shall be issued New Series A1 WDT Interests on account of any unpaid amount of such Claim, and such unpaid amount of such Claim shall be satisfied via Cash distributions pursuant to the priority of payment waterfalls described in Article IV.H and

Article VI.C on account of the New Series A1 WDT Interests issued to the Indenture Trustee in respect of such unpaid amount pursuant to this Plan.

If the Debtors or Wind Down Debtors, as applicable, dispute any requested Indenture Fee and Expense Claims, the Debtors or the Wind Down Debtors, as applicable, shall: (a) pay the undisputed portion of the Indenture Fee and Expense Claims in accordance with this Plan; and (b) notify the Indenture Trustee and the Creditor Proponents of such dispute within two Business Days after presentment of summary invoices by the Indenture Trustee to the Debtors or the Wind Down Trustee, as applicable, and the Creditor Proponents. Upon such notification, the Indenture Trustee may submit such dispute for resolution by the Bankruptcy Court; *provided, however*, that the Bankruptcy Court's review shall be limited to a determination that such amounts are compensable under the Indenture Documents. Nothing herein shall in any way affect or diminish the right of the Indenture Trustee to exercise its Indenture Trustee Charging Lien against distributions on account of Claims under the Indenture Documents with respect to any Indenture Fee and Expense Claims that are not paid pursuant to this Article IV.T. The Indenture Trustee shall provide notice of any intent to exercise its Indenture Trustee Charging Lien against distributions on account of Claims under the Indenture Documents with respect to any unpaid Indenture Fee and Expense Claims to the Debtors or the Wind Down Trustee, as applicable, and the Creditor Proponents, and such parties shall have five (5) Business Days from service of such notice to File an objection with the Bankruptcy Court; *provided, however*, that the Bankruptcy Court's review shall be limited to a determination that such amounts are compensable under the Indenture Documents.

U. Beneficient SPAC Transaction Consents.

For the avoidance of doubt, prior to the Effective Date, any consents necessary in connection with approval of a special purpose acquisition company (SPAC) transaction of Beneficient shall require the consent of the Debtors and the Special Committee and shall be subject to Bankruptcy Court approval. For the avoidance of doubt, the required Bankruptcy Court approval may be contained in an order approving a proposed settlement with Beneficient. After the Effective Date, any such consents shall require the consent of the Wind Down Trustee and shall be subject to Bankruptcy Court approval. For the avoidance of doubt, after the Effective Date, such consent (and request for Bankruptcy Court approval by the Wind Down Trustee) may not include any releases or compromises of any Retained Causes of Action that are transferred to the Litigation Trust on the Effective Date without the consent of the Litigation Trustee.

V. Termination of Any Continuing Business Relationship With Beneficient.

For the avoidance of doubt, on and after the Effective Date, it is expected, whether as the result of the rejection of the Shared Services Agreement or a consensual resolution and termination thereof, that there will be no continuing or other business relationship between the Wind Down Debtors, Wind Down Trust, or Litigation Trust, on the one hand, and Beneficient, on the other, of any nature or type whatsoever, other than the Wind Down Trust's ownership of interests in Beneficient constituting the Wind Down Assets, except as may be necessary or advisable to effectuate a smooth transition of shared services from Beneficient to Portfolio Co. or the Wind Down Trust. The terms of any continued relationship with Beneficient, including any amounts

proposed to be paid to Beneficient, necessary to effect such transition shall be subject to the Proponents' Consent Right.

W. Compensation for Messrs. Stein and Horton.

On the Effective Date, the Debtors shall pay: (1) to Jeffrey S. Stein, a modified "Success Bonus" pursuant to Mr. Stein's Consulting Agreement (as defined in the CRO/ID Order), which shall be (a) \$1,830,000 in Cash, and (b) 40,000 common units of Beneficient owned by the Debtors, in each case to be paid on the Effective Date of this Plan; *provided, however*, that if Beneficient has consummated the special purpose acquisition company transaction of Beneficient prior to the Effective Date, Mr. Stein shall be entitled to receive 50,000 shares of Class A common stock, par value \$0.001 per share, of Beneficient, a Nevada corporation, owned by the Debtors; and (2) to Anthony R. Horton, additional compensation to the compensation payable in accordance with Mr. Horton's engagement letter in the amount of \$120,000 in Cash.

ARTICLE V.

TREATMENT OF EXECUTORY CONTRACTS AND UNEXPIRED LEASES

A. Assumption and Rejection of Executory Contracts and Unexpired Leases.

On the Effective Date, except as otherwise provided herein, all Executory Contracts or Unexpired Leases will be deemed rejected in accordance with the provisions and requirements of sections 365 and 1123 of the Bankruptcy Code, other than: (1) those that are identified on the Schedule of Assumed Executory Contracts and Unexpired Leases; (2) those that have been previously assumed, assumed and assigned, or rejected by a Final Order; (3) those that are the subject of a motion to assume, assume and assign, or reject Executory Contracts or Unexpired Leases that is pending on the Confirmation Date; (4) those that are subject to a motion to assume, assume and assign, or reject an Executory Contract or Unexpired Lease pursuant to which the requested effective date of such assumption, assumption and assignment, or rejection is after the Effective Date; or (5) those Executory Contracts and Unexpired Leases that expired pursuant to the terms thereof before the applicable Petition Date.

Entry of the Confirmation Order shall constitute a Final Order approving the assumptions, assumptions and assignments, or rejections of such Executory Contracts or Unexpired Leases as provided under this Plan or the Schedule of Assumed Executory Contracts and Unexpired Leases, pursuant to sections 365(a) and 1123 of the Bankruptcy Code. Unless otherwise indicated, assumptions or rejections of Executory Contracts and Unexpired Leases pursuant to this Plan are effective as of the Effective Date. Any motions to assume Executory Contracts or Unexpired Leases pending on the Effective Date shall be subject to approval by a Final Order of the Bankruptcy Court on or after the Effective Date.

To the extent any provision in any Executory Contract or Unexpired Lease assumed or assumed and assigned (as applicable) pursuant to this Plan or any prior order of the Bankruptcy Court (including, without limitation, any "change of control" provision) prohibits, restricts or conditions, or purports to prohibit, restrict or condition, or is modified, breached or terminated, or deemed modified, breached or terminated by (a) the commencement of these Chapter 11 Cases or the insolvency or financial condition of any Debtor at any time before the closing of its respective

Chapter 11 Case, (b) any Debtor's or Wind Down Debtor's assumption or assumption and assignment (as applicable) of such Executory Contract or Unexpired Lease, or (c) the Confirmation or Consummation of this Plan, then such provision shall be deemed modified such that the transactions contemplated by this Plan shall not entitle the non-Debtor party thereto to modify or terminate such Executory Contract or Unexpired Lease or to exercise any other default-related rights or remedies with respect thereto, and any required consent under any such Executory Contract or Unexpired Lease shall be deemed satisfied by the Confirmation of this Plan.

Rejection of any Executory Contract or Unexpired Lease pursuant to this Plan or otherwise shall not constitute a termination of any preexisting obligations owed to the Debtors or Wind Down Debtors, as applicable, under such Executory Contracts or Unexpired Leases.

B. Claims Based on Rejection of Executory Contracts or Unexpired Leases.

Proofs of Claim with respect to Claims arising from the rejection of Executory Contracts or Unexpired Leases, if any, must be Filed with the Bankruptcy Court within 30 days after the date of entry of an order of the Bankruptcy Court (including the Confirmation Order) approving such rejection. Any Claims arising from the rejection of an Executory Contract or Unexpired Lease not Filed within such time shall be automatically disallowed, forever barred from assertion, and shall not be enforceable against, as applicable, the Debtors, the Wind Down Debtors, the Wind Down Trustee, the Wind Down Trust, the Litigation Trust, or property of the foregoing parties, without the need for any objection by such parties and without the need for any further notice to, or action, order, or approval of the Bankruptcy Court or any other Entity, and any Claim arising out of the rejection of such Executory Contract or Unexpired Lease shall be deemed fully satisfied, released, and discharged, notwithstanding anything to the contrary in the Schedules or a Proof of Claim. Claims arising from the rejection of the Debtors' Executory Contracts or Unexpired Leases shall be classified as General Unsecured Claims in Class 4(a) or a GUC Convenience Claim in Class 4(b), depending on the amount of the Allowed Claim (or, to the extent the counterparty to the rejected Executory Contract or Unexpired Lease is one of the DLP Entities, Class 5), and shall be treated in accordance with Article III and Article IV.H of this Plan, as applicable.

C. Cure of Defaults for Assumed Executory Contracts and Unexpired Leases.

Any monetary defaults under an Executory Contract and Unexpired Lease, as reflected on the Schedule of Assumed Executory Contracts and Unexpired Leases, shall be satisfied, pursuant to section 365(b)(1) of the Bankruptcy Code, by payment of the Cure Amount in Cash on the Effective Date, subject to the limitations described below, or on such other terms as the parties to such Executory Contracts or Unexpired Leases may otherwise agree. In the event of a dispute regarding (1) the Cure Amount, (2) the ability of the Wind Down Debtors or any assignee to provide "adequate assurance of future performance" (within the meaning of section 365 of the Bankruptcy Code) under the Executory Contract or Unexpired Lease to be assumed, or (3) any other matter pertaining to assumption, the cure payments required by section 365(b)(1) of the Bankruptcy Code shall be made following the entry of a Final Order or orders resolving the dispute and approving the assumption.

In any case, if the Bankruptcy Court determines that the Allowed Cure Amount with respect to any Executory Contract or Unexpired Lease is greater than the amount set forth in the

Schedule of Assumed Executory Contracts and Unexpired Leases, the Debtors or the Wind Down Debtors, as applicable, will have the right to remove such Executory Contract or Unexpired Lease from the Schedule of Assumed Executory Contracts and Unexpired Leases, in which case such Executory Contract or Unexpired Lease will be deemed rejected as the Effective Date.

Assumption of any Executory Contract or Unexpired Lease pursuant to this Plan or otherwise shall result in the full release and satisfaction of any Claims or defaults, whether monetary or nonmonetary, including defaults of provisions restricting the change in control or ownership interest composition or other bankruptcy-related defaults, arising under any assumed Executory Contract or Unexpired Lease at any time before the date that the Debtors assume such Executory Contract or Unexpired Lease. Any Proofs of Claim Filed with respect to an Executory Contract or Unexpired Lease that has been assumed shall be deemed disallowed and expunged, without further notice to or action, order, or approval of the Bankruptcy Court.

Any objection regarding the ability of the Wind Down Debtors to provide “adequate assurance of future performance” (within the meaning of section 365 of the Bankruptcy Code) must have been Filed with the Bankruptcy Court by the deadline set by the Bankruptcy Court for objecting to Confirmation of the Plan. To the extent any such objection is not determined by the Bankruptcy Court at the Confirmation Hearing, such objection may be heard and determined at a subsequent hearing. Any counterparty to an Executory Contract or Unexpired Lease of the Debtors that does not timely object to such “adequate assurance of future performance” by such deadline will be deemed to have forever released and waived any such objection.

D. Insurance Policies.

Notwithstanding anything herein to the contrary, the Debtors shall retain the ability to supplement any D&O Liability Insurance Policies as the Debtors deem necessary, including purchasing any tail coverage. For the avoidance of doubt, prior to the Effective Date, the Debtors shall obtain additional director and officer liability tail insurance coverage for the period from April 20, 2022 to the Effective Date, which insurance coverage must not terminate or otherwise reduce the coverage set forth in the existing D&O Liability Insurance Policies. On and after the Effective Date, Portfolio Co., the Wind Down Trust, and the Litigation Trust, as applicable, shall be authorized to obtain additional director and officer or similar liability coverage for Portfolio Co., the Wind Down Trustee and the Litigation Trustee, as applicable, for the period following the Effective Date.

E. Modifications, Amendments, Supplements, Restatements, or Other Agreements.

Unless otherwise provided in this Plan, each Executory Contract or Unexpired Lease that is assumed shall include all modifications, amendments, supplements, restatements, or other agreements that in any manner affect such Executory Contract or Unexpired Lease, and Executory Contracts and Unexpired Leases related thereto, if any, including easements, licenses, permits, rights, privileges, immunities, options, rights of first refusal, and any other interests, unless any of

the foregoing agreements has been previously rejected or repudiated or is rejected or repudiated under the Plan.

Modifications, amendments, supplements, and restatements to prepetition Executory Contracts and Unexpired Leases that have been executed by the Debtors during the Chapter 11 Cases shall not be deemed to alter the prepetition nature of the Executory Contract or Unexpired Lease, or the validity, priority, or amount of any Claims that may arise in connection therewith.

F. Reservation of Rights.

Neither the exclusion nor inclusion of any Executory Contract or Unexpired Lease on the Schedule of Assumed Executory Contracts and Unexpired Leases, nor anything contained in the Plan, shall constitute an admission by the Debtors or any other Entity, as applicable, that any such contract or lease is in fact an Executory Contract or Unexpired Lease or that either any Debtor or any other Entity, as applicable, has any liability thereunder.

G. Non-occurrence of the Effective Date.

In the event that the Effective Date does not occur, the Bankruptcy Court shall retain jurisdiction with respect to any request to extend the deadline for assuming or rejecting Unexpired Leases pursuant to section 365(d)(4) of the Bankruptcy Code.

**ARTICLE VI.
PROVISIONS GOVERNING DISTRIBUTIONS**

A. Timing and Calculation of Amounts to Be Distributed.

Unless otherwise provided in this Plan or the Confirmation Order (and except with respect to Cash distributions from the Wind Down Trust or the Litigation Trust), on the Effective Date (or if a Claim is not an Allowed Claim on the Effective Date, on the date that such Claim becomes an Allowed Claim, or as soon as reasonably practicable thereafter), each Holder of an Allowed Claim entitled to a Cash distribution on the Effective Date shall receive the full amount of the distributions that the Plan provides for such Allowed Claim as set forth in Article III hereof. In the event that any payment or act under this Plan is required to be made or performed on a date that is not a Business Day, then the making of such payment or the performance of such act may be completed on the next succeeding Business Day, but shall be deemed to have been completed as of the required date. If and to the extent that there are Disputed Claims, distributions on account of any such Disputed Claims shall be made pursuant to Article VII (or, with respect to LBM, Article VI.C) hereof. Except as otherwise expressly provided in this Plan, Holders of Claims and Interests shall not be entitled to interest, dividends, or accruals on the distributions provided for herein, regardless of whether such distributions are delivered on or at any time after the Effective Date.

B. Distributing Parties.

After the Effective Date, all distributions under this Plan shall be made by or at the direction of the Wind Down Trustee on behalf of the Debtors or the Wind Down Trust, as applicable. The

Wind Down Trustee shall not be required to give any bond or surety or other security for the performance of its duties unless otherwise ordered by the Bankruptcy Court.

Subject to the terms of this Plan, the Wind Down Trustee shall be empowered to: (a) effect all actions and execute all agreements, instruments, and other documents necessary to perform its duties under the Plan; (b) make all distributions contemplated under the Plan; (c) employ professionals to represent it with respect to its responsibilities; and (d) exercise such other powers as may be vested in the Wind Down Debtors or the Wind Down Trustee, as applicable, by order of the Bankruptcy Court, pursuant to this Plan, or as deemed by the Wind Down Trustee to be necessary and proper to implement the provisions of hereof.

C. Delivery of Distributions Related to the Litigation Trust.

All distributions of the net proceeds realized by the Litigation Trust shall be made by the Wind Down Trustee (or by the Litigation Trustee, at the direction of the Wind Down Trustee) pursuant to the terms of this Plan and governed by the Litigation Trust Agreement.

Distributions of net proceeds realized by the Litigation Trust shall be made by the Wind Down Trustee, or by the Litigation Trustee at the direction of the Wind Down Trustee, in the following order of priority (with no distributions to junior classes until each senior class is paid in full):

1. to holders of New Series A1 WDT Interests (subject to prior payment in full of Indenture Fee and Expense Claims) on account of the Indenture Diminution Claims, up to the Allowed amount of such Claims;
2. on a *pari passu* pro rata basis (a) holders of the New Series A1 WDT Interests and the New Series A2 WDT Interests (subject to the prior payment in full of the Indenture Fee and Expense Claims and recognizing the intercreditor arrangements described in Article IV.H.1 through H.4 hereof vis-à-vis the New Series A1 WDT Interests and the New Series A2 WDT Interests), on the one hand, and (b) holders of New Series B WDT Interests on the other hand, up to the aggregate outstanding prepetition amounts of Allowed Bondholder Claims and Allowed LBM Subordinated Claims in Class 3, and Allowed Class 4(a) General Unsecured Claims, calculated in accordance with Article IV.H hereof;
3. on a *pari passu* pro rata basis (a) holders of the New Series A1 WDT Interests and the New Series A2 WDT Interests (subject to recognizing the intercreditor arrangements described in Article IV.H.1 through H.4 hereof vis-à-vis the New Series A1 WDT Interests and the New Series A2 WDT Interests), on the one hand, and (b) holders of New Series B WDT Interests on the other hand, up to the amount of interest accrued on such New Series A1 WDT Interests and New Series A2 WDT Interests as set forth in the New WDT Documents, and Allowed Class 4(a) General Unsecured Claims, calculated in accordance with Article IV.H hereof;
4. holders of New Series C WDT Interests and New Series D WDT Interests on a *pari passu* pro rata basis, per liquidation rights under the New WDT Documents and applicable law, up to the outstanding Allowed aggregate amount of the Class 8

Series 1 Preferred Interests and Class 9 Series 2 Preferred Interests (based on each Series 1 Preferred Interest and each Series 2 Preferred Interest having an initial stated value of \$1,000.00 per share); and

5. holders of the New Series E WDT Interests.

D. Delivery of Distributions and Undeliverable or Unclaimed Distributions.

1. Record Date for Distributions.

On the Distribution Record Date, the Claims Register shall be closed and any party responsible for making distributions shall instead be authorized and entitled to recognize only those record Holders listed on the Claims Register as of the close of business on the Distribution Record Date. Accordingly, any party responsible for making distributions will have no obligation to recognize the assignment, transfer or other disposition of, or the sale of any participation in, any Allowed Claim listed on the Claims Register that occurs after the close of business on the Distribution Record Date.

2. Delivery of Distributions in General.

Except as otherwise provided herein, the Wind Down Trustee shall make distributions to Holders of Allowed Claims and Allowed Interests as of the Distribution Record Date at the address for each such Holder as indicated on the Debtors' records as of the date of any such distribution; *provided*, that the manner of such distributions shall be determined at the discretion of the Wind Down Trustee; *provided, further*, that the address for each Holder of an Allowed Claim or Allowed Interest shall be deemed to be the address set forth in any Proof of Claim or Interest Filed by that Holder pursuant to Bankruptcy Rule 3001. If a Holder holds more than one Claim or Interest in any one Class, all Claims or Interests, as applicable, of the Holder will be aggregated into one Claim or Interest and one distribution will be made with respect to the aggregated Claim (to the extent possible). The Indenture Trustee Charging Lien shall attach to any distributions made to the Holders of Claims under the Indenture Documents in the same manner as if such distributions were made through the Indenture Trustee.

Notwithstanding any policies, practices, or procedures of DTC, DTC shall cooperate with and take all actions reasonably requested by the Wind Down Trustee or the Indenture Trustee to facilitate distributions to Holders of Allowed Bond Claims without requiring that such distributions be characterized as repayments of principal or interest. Neither the Wind Down Trustee nor the Indenture Trustee shall be required to provide indemnification or other security to DTC in connection with any distributions to Holders of Allowed Bond Claims through the facilities of DTC. The Indenture Trustee shall not incur any liability whatsoever on account of any distributions under this Plan.

3. Minimum Distributions.

Notwithstanding anything to the contrary herein, no Cash payment of less than \$100.00, in the reasonable discretion of the Wind Down Trustee, shall be made to a Holder of an Allowed Claim or Allowed Interest on account of such Allowed Claim or Allowed Interest. Each such Claim or Interest to which this limitation applies shall be discharged pursuant to Article VIII of

this Plan, and its Holder shall be forever barred pursuant to Article III hereof from asserting that Claim against or Interest in the Wind Down Debtors, the Wind Down Trustee, the Wind Down Trust, or the Litigation Trust, or any property of the foregoing.

No fractional interests of New WDT Interests shall be distributed and no Cash shall be distributed in lieu of such fractional amounts. When any distribution pursuant to the Plan on account of an Allowed Claim or Allowed Interest (as applicable) would otherwise result in the issuance of a number of New WDT Interests that is not a whole number, the actual distribution of New WDT Interests shall be rounded as follows: (a) fractions of one-half (1/2) or greater shall be rounded to the next higher whole number; and (b) fractions of less than one-half (1/2) shall be rounded to the next lower whole number with no further payment therefor. The total number of authorized New WDT Interests to be distributed to Holders of Allowed Claims and Allowed Interests shall be adjusted as necessary to account for the foregoing rounding.

4. Undeliverable Distributions and Unclaimed Property.

In the event that either (a) a distribution to any Holder is returned as undeliverable or (b) the Holder of an Allowed Claim or Allowed Interest does not timely respond to a request by the Debtors or the Wind Down Trustee for information necessary to facilitate a particular distribution, no distribution to such Holder shall be made unless and until the Wind Down Trustee is notified in writing of the then-current address of such Holder or the Wind Down Trustee has received the necessary information with sufficient time to facilitate a particular distribution, at which time such distribution shall be made to such Holder without interest, dividends, or other accruals of any kind; *provided*, that such distributions shall be deemed unclaimed property under section 347(b) of the Bankruptcy Code on the date that is six months after the later of (x) the Effective Date and (y) the date of the distribution; *provided, further*, that the Wind Down Trustee shall use commercially reasonable efforts to accurately determine the address or other contact information for any Holder (or holder, as applicable) that does not hold such Class 3 Bond Claims or New WDT Interests through DTC or by other indirect means before such distribution may be deemed unclaimed property. After such date, all unclaimed property or interests in property shall revert to the Wind Down Trust automatically and without need for a further order by the Bankruptcy Court (notwithstanding any applicable local, state, federal, or foreign escheat, abandoned, or unclaimed property laws to the contrary), and the Claim or Interest of any Holder to such property or interest in property shall be discharged and forever barred. For the avoidance of doubt, any unclaimed property in the form of Cash shall be distributed in accordance with Article III, Article IV.H, and Article VI.C of this Plan to Holders of Claims within the same Class to which the unclaimed property was to be distributed.

5. Manner of Payment Pursuant to the Plan.

Any payment in Cash to be made pursuant to the Plan shall be made at the election of the Wind Down Trustee by check or by wire transfer, at the sole and exclusive discretion of the Wind Down Trustee.

E. Single Satisfaction of Claims and Interests.

In no case shall the aggregate value of all property received or retained under this Plan on account of each Allowed Claim or Allowed Interest exceed 100% of the underlying Allowed Claim or Allowed Interest (plus any applicable interest).

F. No Postpetition Interest On Claims.

Unless otherwise specifically provided for in the Plan, the Confirmation Order, or Final Order of the Bankruptcy Court, or required by applicable bankruptcy or non-bankruptcy law (including, without limitation, as required pursuant to section 506(b) and section 511 of the Bankruptcy Code), postpetition interest shall not accrue or be paid on any prepetition Claims against the Debtors, and no Holder of a prepetition Claim against the Debtors shall be entitled to interest accruing on or after the applicable Petition Date on any such prepetition Claim. Additionally, and without limiting the foregoing, interest shall not accrue or be paid on any Disputed Claim with respect to the period from the Effective Date to the date a final distribution is made on account of such Disputed Claim, until such Disputed Claim becomes an Allowed Claim.

G. Compliance with Tax Requirements/Allocations.

In connection with the Plan and all distributions hereunder, to the extent applicable, the Debtors, the Wind Down Debtors, Wind Down Trustee, the Wind Down Trust, the Litigation Trust, and any applicable withholding agent shall comply with all tax withholding and reporting requirements imposed on them by any Governmental Unit, and all distributions made pursuant to the Plan shall be subject to such withholding and reporting requirements. Notwithstanding any provision in the Plan to the contrary, such parties shall (1) be authorized to take all actions necessary or appropriate to comply with such withholding and reporting requirements, including liquidating a portion of the distribution to be made under the Plan to generate sufficient funds to pay applicable withholding taxes, withholding distributions pending receipt of information necessary to facilitate such distributions, or establishing any other mechanisms they believe are reasonable and appropriate, and (2) shall reasonably cooperate with the relevant recipients to minimize any such withholding to the extent permitted by applicable law. The Debtors, the Wind Down Debtors, the Wind Down Trustee, the Wind Down Trust, and the Litigation Trust each reserve the right to allocate all distributions made under the Plan in compliance with all applicable wage garnishments, alimony, child support, and other spousal awards, Liens, and encumbrances.

Distributions in respect of Allowed Claims shall be allocated first to the principal amount of such Claims (as determined for federal income tax purposes) and then, to the extent the consideration exceeds the principal amount of the Claims, to any portion of such Claims for accrued but unpaid interest.

H. Setoffs.

Except as otherwise expressly provided for herein, the Wind Down Trustee, pursuant to the Bankruptcy Code (including section 553 of the Bankruptcy Code), applicable non-bankruptcy law, or as may be agreed to by the Holder of a Claim, may exercise setoff rights against any Allowed Claim and the distributions to be made pursuant to the Plan on account of such Allowed

Claim (before any distribution is made on account of such Allowed Claim), any claims, rights, and Causes of Action of any nature that such Debtor or Wind Down Debtor, as applicable, may hold against the Holder of such Allowed Claim, to the extent such claims, rights, or Causes of Action against such Holder have not been otherwise compromised or settled on or prior to the Effective Date (whether pursuant to the Plan or otherwise); *provided, however*, that neither the failure to effect such a setoff nor the allowance of any Claim pursuant to the Plan shall constitute a waiver or release by the Wind Down Trustee of any such claims, rights, and Causes of Action that the Wind Down Trustee may possess against such Holder; *provided, further*, that such Holder may contest any such set off by the Wind Down Trustee in the Bankruptcy Court or any other court of competent jurisdiction. For the avoidance of doubt, any such right of setoff may be preserved by timely Filing a Proof of Claim related to such right of setoff.

I. Allocation of Plan Distributions between Principal and Interest.

To the extent that any Allowed Claim entitled to a distribution under this Plan is comprised of indebtedness and accrued but unpaid interest thereon, such distribution shall, to the extent permitted by applicable law, be allocated for U.S. federal income tax purposes to the principal amount of the Claim first and then, to the extent that the consideration exceeds the principal amount of the Claim, to the portion of the Claim representing accrued but unpaid interest.

J. Claims Paid or Payable by Third Parties.

1. Claims Paid by Third Parties.

The Debtors or the Wind Down Trustee, as applicable, shall reduce in full a Claim, and such Claim shall be disallowed without a Claims objection having to be Filed and without any further notice to or action, order, or approval of the Bankruptcy Court, to the extent that the Holder of such Claim receives payment in full on account of such Claim from a party that is not a Debtor or the Wind Down Trustee. Subject to the last sentence of this paragraph, to the extent a Holder of a Claim receives a distribution on account of such Claim and receives payment from a party that is not a Debtor on account of such Claim, such Holder shall, within 14 days of receipt thereof, repay or return the distribution to the Wind Down Trustee to the extent the Holder's total recovery on account of such Claim from the third party and under the Plan exceeds the amount of such Claim as of the date of any such distribution under the Plan. The failure of such Holder to timely repay or return such distribution shall result in the Holder owing the Wind Down Trustee annualized interest at the Federal Judgment Rate on such amount owed for each Business Day after the 14-day grace period specified above until the amount is repaid.

2. Claims Payable by Third Parties.

Other than with respect to Class 3, no distributions under the Plan shall be made on account of a Claim that is payable by a third party (including by an Entity that is jointly and severally liable on such Claim and/or by one or more of the Debtors' insurers pursuant to one of the Debtors' insurance policies) until the Holder of such Claim has exhausted all rights and remedies with respect to such third party (including adjudicating any liability of any Entity that is jointly and severally liable on such Claim and/or adjudicating its rights under any applicable insurance policy). To the extent that any third party (including one or more of the Debtors' insurers) agrees

to satisfy in full or in part a Claim or such Claim is adjudicated by the Bankruptcy Court or another court of competent jurisdiction, the applicable portion of such Claim shall be automatically expunged without a Claims objection having to be Filed and without any further notice to or action, order, or approval of the Bankruptcy Court.

3. Applicability of Insurance Policies.

Except as otherwise provided in the Plan, distributions to Holders of Allowed Claims shall be in accordance with the provisions of any applicable insurance policy. Nothing contained in the Plan shall constitute or be deemed a waiver of any Cause of Action that the Debtors or any Entity may hold against any other Entity, including insurers under any policies of insurance, nor shall anything contained herein constitute or be deemed a waiver by such insurers of any defenses, including coverage defenses, held by such insurers.

ARTICLE VII. PROCEDURES FOR RESOLVING CONTINGENT, UNLIQUIDATED, AND DISPUTED CLAIMS

A. Allowance of Claims.

After the Effective Date, and subject to the terms of this Plan and the Confirmation Order, the Wind Down Trustee shall have and retain any and all rights and defenses such Debtor had with respect to any Claim or Interest immediately prior to the Effective Date. The Debtors may affirmatively determine to deem Unimpaired Claims Allowed to the same extent such Claims would be allowed under applicable non-bankruptcy law. No Claim shall become an Allowed Claim prior to the Claim Objection Bar Date unless and until such Claim is deemed Allowed under the Plan or the Bankruptcy Code, or the Bankruptcy Court has entered a Final Order (including the Confirmation Order) in the Chapter 11 Cases Allowing such Claim.

B. Claims Administration Responsibilities.

Except as otherwise specifically provided in the Plan, and notwithstanding any requirements that may be imposed pursuant to Bankruptcy Rule 9019, after the Effective Date, but not later than the Claims Objection Bar Date, the Wind Down Trustee shall have the sole authority: (1) to File, withdraw, or litigate to judgment objections to Claims or Interests (other than Claims or Interests deemed to be Allowed in this Plan); (2) to settle, compromise, or resolve any Disputed Claim or Disputed Interest without any further notice to or action, order, or approval by the Bankruptcy Court; and (3) to administer and adjust the Claims Register to reflect any such settlements or compromises without any further notice to or action, order, or approval by the Bankruptcy Court; *provided*, that, notwithstanding the foregoing, the Litigation Trustee shall have the sole authority to, on or before the Claims Objection Bar Date, File, withdraw, or litigate to judgment objections to Litigation Trust Reconciliation Claims, including any such Claims that are Disputed Claims or Interests. Notwithstanding the foregoing, the entry into any settlement of any Claim, settlement, or dispute with an economic value of \$5 million or more shall (on an individual basis) require the approval of the Bankruptcy Court after notice and an opportunity for a hearing. For the avoidance of doubt, except as otherwise provided herein, from and after the Effective Date, the Wind Down Trustee and the Litigation Trustee, as applicable, shall have and retain any and all

rights and defenses such Debtor had immediately prior to the Effective Date with respect to any Disputed Claim or Interest.

C. Estimation of Claims.

Before or after the Effective Date, the Debtors or Wind Down Debtors may (but are not required to), at any time, request that the Bankruptcy Court estimate any Disputed Claim or contingent or unliquidated Claim pursuant to applicable law, including pursuant to section 502(c) of the Bankruptcy Code and/or Bankruptcy Rule 3012, for any reason, regardless of whether any party previously has objected to such Claim or whether the Bankruptcy Court has ruled on any such objection, and the Bankruptcy Court shall retain jurisdiction under 28 U.S.C. §§ 157 and 1334 to estimate any such Claim, including during the litigation of any objection to any Claim or during the pendency of any appeal relating to such objection. Notwithstanding any provision otherwise in the Plan, a Claim that has been expunged from the Claims Register, but that either is subject to appeal or has not been the subject of a Final Order, shall be deemed to be estimated at zero dollars, unless otherwise ordered by the Bankruptcy Court. In the event that the Bankruptcy Court estimates any Claim, that estimated amount shall constitute a maximum limitation on such Claim for all purposes under the Plan (including for purposes of distributions) and may be used as evidence in any supplemental proceedings, and the Debtors or the Wind Down Trustee, as applicable, may elect to pursue any supplemental proceedings to object to any ultimate distribution on such Claim. Notwithstanding section 502(j) of the Bankruptcy Code, in no event shall any Holder of a Claim that has been estimated pursuant to section 502(c) of the Bankruptcy Code or otherwise be entitled to seek reconsideration of such estimation unless such Holder has Filed a motion requesting the right to seek such reconsideration on or before 7 days after the date on which such Claim is estimated. Each of the foregoing Claims and objection, estimation, and resolution procedures are cumulative and not exclusive of one another. Claims may be estimated and subsequently compromised, settled, withdrawn, or resolved by any mechanism approved by the Bankruptcy Court.

D. Adjustment to Claims or Interests without Objection.

Any duplicate Claim or Interest, any Claim or Interest that is substantiated by an invoice that is invalid, previously rejected, or otherwise deemed erroneous by the Debtors, or any Claim or Interest that has been paid, satisfied, amended, or superseded, may be adjusted or expunged on the Claims Register by the Debtors or the Wind Down Trustee, as applicable, without the Debtors or the Wind Down Trustee, as applicable, having to File an application, motion, complaint, objection, or any other legal proceeding seeking to object to such Claim or Interest and without any further notice to or action, order, or approval of the Bankruptcy Court.

E. Disallowance of Claims and Interests.

All Claims or Interests held by Entities from which property is recoverable under sections 542, 543, 550, or 553 of the Bankruptcy Code or that the Debtors, the Wind Down Trust, or the Litigation Trust, as applicable, allege is a transferee of a transfer avoidable under sections 522(f), 522(h), 544, 545, 547, 548, 549, or 724(a) of the Bankruptcy Code, shall be deemed disallowed pursuant to section 502(d) of the Bankruptcy Code, and Holders of such Claims or Interests may not receive any distributions on account of such Claims until such time as such

Causes of Action against that Entity have been settled or a Bankruptcy Court order with respect thereto has been entered and all sums due, if any, to the Debtors by that Entity have been turned over or paid to the Wind Down Trustee. All Proofs of Claim Filed on account of an indemnification obligation to a director, officer, or employee shall be deemed satisfied and expunged from the Claims Register as of the Effective Date to the extent such indemnification obligation is assumed (or honored or reaffirmed, as the case may be) pursuant to this Plan, without any further notice to or action, order, or approval of the Bankruptcy Court; *provided, however*, for the avoidance of doubt, no indemnification obligations of the Debtors to any former directors, officers, or employees of the Debtors or any other indemnification obligations of the Debtors arising from or relating to the prepetition period shall be assumed (provided, however, that nothing contained herein is intended to adversely affect any such director's, officer's, or employee's rights to an interest in Side A coverage under such policies).

Except as otherwise provided herein, if a party Files a Proof of Claim and the Debtors or the Wind Down Trustee, as applicable, do not determine, and without the need for notice to or action, order, or approval of the Bankruptcy Court, that the Claim subject to such Proof of Claim is Allowed, such Claim shall be Disputed unless Allowed or disallowed by a Final Order or as otherwise set forth in this Plan. Except as provided herein or otherwise agreed, any and all Proofs of Claim Filed after the applicable Claims Bar Date shall be deemed disallowed and forever barred, estopped, and enjoined from assertion and expunged as of the Effective Date without any further notice to or action, order, or approval of the Bankruptcy Court, and Holders of such Claims may not receive any distributions on account of such Claims, unless on or before the Confirmation Hearing such late Claim has been deemed timely Filed by a Final Order.

F. Disputed Claims Reserve.

On or before the Effective Date, the Debtors or the Wind Down Trustee, as applicable, shall deposit in the Disputed Claims Reserve the Disputed Claims Reserve Amount to the extent applicable and to the extent of Cash available or realized for distribution. The Wind Down Trustee shall administer the Disputed Claims Reserve and shall distribute amounts held in the Disputed Claims Reserve (net of any expenses, including any taxes relating thereto), as provided herein, as such Disputed Claims are resolved by a Final Order or agreed to by settlement, and such amounts will be distributable on account of such Disputed Claims as such amounts would have been distributable had such Disputed Claims been Allowed Claims as of the Effective Date solely to the extent of the amounts available in the applicable reserves. For the avoidance of doubt, any Cash held in the Disputed Claims Reserve on account of a Disputed Class 3 Bond Claim is ultimately disallowed by a Final Order or otherwise resolved between the Holder of the Disputed Claim and the Wind Down Debtors shall be distributed to other Holders of Class 3 Bond Claims in Accordance with Article III and Article IV.H of the Plan. The Wind Down Trustee (1) may timely elect to treat any Wind Down Trust Assets allocable to Disputed Claims as a “disputed ownership fund” governed by Treas. Reg. § 1.468B-9, and (2) to the extent permitted by applicable law, shall report consistently for state and local income tax purposes. If a “disputed ownership fund” election is made, all parties (including the Wind Down Trustee and New WDT Interests holders) shall report for United States federal, state and local income tax purposes consistently with the foregoing.

G. Amendments to Claims.

On or after the Effective Date, except as provided in the Plan or the Confirmation Order, a Claim or Interest may not be Filed or amended without the prior authorization of the Debtors or the Wind Down Debtors, as applicable, or the Bankruptcy Court, and any such new or amended Claim or Interest Filed shall be deemed disallowed in full and expunged without any further action, order, or approval of the Bankruptcy Court.

H. No Distributions Pending Allowance.

If an objection to a Claim or Interest or portion thereof is Filed as set forth in Article VII of this Plan, or if such Claim or Interest is scheduled as Disputed, no payment or distribution provided under the Plan shall be made on account of such Claim or Interest or any portion thereof unless and until such Disputed Claim or Disputed Interest becomes an Allowed Claim or Allowed Interest, unless otherwise determined by the Debtors or the Wind Down Trustee.

I. Distributions After Allowance.

To the extent that a Disputed Claim or Disputed Interest ultimately becomes an Allowed Claim or Allowed Interest, distributions (if any) shall be made to the Holder of such Allowed Claim or Allowed Interest in accordance with the provisions of this Plan. As soon as practicable after the date that the order or judgment of the Bankruptcy Court Allowing any Disputed Claim or Disputed Interest becomes a Final Order, the Wind Down Trustee shall provide to the Holder of such Claim or Interest the distribution (if any) to which such Holder is entitled under the Plan as of the Effective Date, less any previous distribution (if any) that was made on account of the undisputed portion of such Claim or Interest, without any interest, dividends, or accruals to be paid on account of such Claim or Interest unless required under applicable bankruptcy law or as otherwise provided in Article III.B of this Plan.

ARTICLE VIII.

SETTLEMENT, RELEASE, INJUNCTION, AND RELATED PROVISIONS

A. Settlement, Compromise, and Release of Claims and Interests.

Except as otherwise specifically provided in the Plan or in any contract, instrument, or other agreement or document created or entered into pursuant to the Plan, the distributions, rights, and treatment that are provided in the Plan shall be in complete satisfaction and release, effective as of the Effective Date, of Claims, Interests, and Causes of Action of any nature whatsoever, whether liquidated or unliquidated, fixed or contingent, matured or unmatured, including any interest accrued on Claims or Interests from and after the applicable Petition Date, whether known or unknown, against, liabilities of, Liens on, obligations of, rights against, and Interests in, the Debtors or any of their assets or properties, regardless of whether any property shall have been distributed or retained pursuant to the Plan on account of such Claims and Interests, including demands, liabilities, and Causes of Action that arose before the Effective Date, any liability (including withdrawal liability) to the extent such Claims or Interests relate to services performed by employees of the Debtors prior to the Effective Date and that arise from a termination of employment, any contingent or non-contingent liability on account of representations or warranties issued on or before the Effective Date, all debts of the kind specified in sections 502(g), 502(h),

or 502(i) of the Bankruptcy Code, in each case whether or not: (1) a Proof of Claim based upon such debt or right is Filed or deemed Filed pursuant to section 501 of the Bankruptcy Code; (2) a Claim or Interest based upon such debt, right, or interest is Allowed pursuant to section 502 of the Bankruptcy Code; or (3) the holder of such a Claim or Interest has accepted the Plan. The Confirmation Order shall be a judicial determination that the holders of Claims, Interests, and Causes of Action shall be limited to the distributions, if any, under this Plan for the satisfaction of such Claims, Interests, and Causes of Action against the Debtors and that, subject to the occurrence of the Effective Date, the distributions hereunder shall be in complete satisfaction of such Claims, Interests and Causes of Action insofar as the satisfaction of such Claims, Interests, and Causes of Action from any asset of the Debtors shall be concerned.

B. Release of Liens.

Except as otherwise provided herein or in any contract, instrument, release, or other agreement or document created pursuant to or in connection with the Plan, the Confirmation Order, or any contract, instrument, release, or other agreement or document created pursuant to the Plan, on the Effective Date and concurrently with the applicable distributions made pursuant to the Plan and, in the case of a Secured Claim, satisfaction in full of the portion of the Secured Claim that is Allowed as of the Effective Date, all mortgages, deeds of trust, Liens, pledges, or other security interests against any property of the Estates shall be fully released and discharged, and all of the right, title, and interest of any Holder of such mortgages, deeds of trust, Liens, pledges, or other security interests shall revert to the Debtors and their successors and assigns (including the Wind Down Debtors, Wind Down Trust, and/or the Litigation Trust, as applicable). Any Holder of such Secured Claim (and the applicable agents for such Holder) shall be authorized and directed, at the sole cost and expense of the Wind Down Trust, to release any collateral or other property of any Debtor or their successors and assigns (including the Wind Down Debtors, Wind Down Trust, and/or the Litigation Trust, as applicable), including any cash collateral and possessory collateral, held by such Holder (and the applicable agents for such Holder), and to take such actions as may be reasonably requested by the Wind Down Trust to evidence the release of such Lien, including the execution, delivery, and filing or recording of such releases. The presentation or filing of the Confirmation Order to or with any federal, state, provincial, or local agency or department shall constitute good and sufficient evidence of, but shall not be required to effect, the termination of such Liens.

C. Releases by the Debtors.

Pursuant to section 1123(b) of the Bankruptcy Code, in exchange for good and valuable consideration, the adequacy of which is hereby confirmed, on and after the Effective Date, each Released Party (but no Non-Released Party) is, and is deemed hereby to be, fully, conclusively, absolutely, unconditionally, irrevocably, and forever released and discharged by the Debtors, the Wind Down Debtors, and their Estates, and any person seeking to exercise the rights of the Debtors or their Estates, including any successors to the Debtors or any Estates representatives appointed or selected pursuant to section 1123(b)(3) of the Bankruptcy Code, in each case on behalf of themselves and their respective successors, assigns, and representatives, and any and all other Entities who may purport to assert any Cause of Action, directly or derivatively, by, through or for the Debtors or their Estates,

from any and all Claims and Causes of Action, whether known or unknown, including any derivative claims, asserted or assertable on behalf of the Debtors, whether known or unknown, foreseen or unforeseen, matured or unmatured, existing or hereafter arising, contingent or non-contingent, in law, equity, contract, tort or otherwise, except for any claims related to any act or omission that is determined in a Final Order to have constituted actual fraud, willful misconduct, intentional breach of fiduciary duty, or gross negligence, that the Debtors, the Wind Down Debtors, or their Estates, including any successors to the Debtors or any Estates representative appointed or selected pursuant to section 1123(b) of the Bankruptcy Code, would have been legally entitled to assert in their own right (whether individually or collectively) or on behalf of the Holder of any Claim or Interest in, a Debtor or other Entity, or that any Holder of any Claim against, or Interest in, a Debtor or other Entity could have asserted on behalf of the Debtors, based on or relating to, or in any manner arising from, in whole or in part, the Debtors (including the capital structure, management, ownership or operation thereof), the business or contractual arrangement between the Debtors and any Released Party, any Securities issued by the Debtors and the ownership thereof, the assertion or enforcement of rights and remedies against the Debtors, the Debtors' in- or out-of-court restructuring efforts, any Avoidance Actions (but excluding Avoidance Actions brought as counterclaims or defenses to Claims asserted against the Debtors), intercompany transactions between or among a Debtor and another Debtor, the formulation, preparation, dissemination, negotiation, or Filing of the Disclosure Statement, the Plan (including, for the avoidance of doubt, the Plan Supplement), the Vida DIP Financing Facility, the Vida Exit Financing Facility, or any Wind Down Transaction, contract, instrument, release, or other agreement or document (including any legal opinion requested by any Entity regarding any transaction, contract, instrument, document or other agreement contemplated by the Plan or the reliance by any Released Party on the Plan or the Confirmation Order in lieu of such legal opinion) created or entered into in connection with the Disclosure Statement, the Vida Exit Financing Facility Documents, the Plan, or the Plan Supplement, before or during the Chapter 11 Cases, the Chapter 11 Cases, the filing of the Chapter 11 Cases, the pursuit of Confirmation, the administration and implementation of the Plan, including the issuance or distribution of Securities pursuant to the Plan, or the distribution of property under the Plan, or upon any related act or omission, transaction, agreement, event, or other occurrence related or relating to any of the foregoing taking place on or before the Effective Date related or relating to the foregoing including all relief obtained by the Debtors in the Chapter 11 Cases. For the avoidance of doubt, the LBM Released Parties, to the extent that LBM has not withdrawn from the settlement described in Article IV.I of this Plan, shall constitute Released Parties with respect to this Debtor Release.

Notwithstanding anything to the contrary in the foregoing, the releases set forth above do not release: (1) post-Effective Date obligations of any party or Entity under the Plan, the Confirmation Order, any Wind Down Transaction, or any other document, instrument, or agreement (including those set forth in the Plan Supplement) executed to implement the Plan, including the Vida Exit Financing Facility Documents, or any Claim or obligation arising under the Plan; (2) the rights of any Holder of Allowed Claims to receive distributions under the Plan; (3) the Retained Causes of Action; (4) any claims related to any act or omission that is determined in a Final Order to have constituted actual fraud, willful misconduct, intentional breach of fiduciary duty, or gross negligence; (5) the Debtors'

prepetition legal counsel solely with respect to claims or causes of action arising from such counsel's prepetition advice to the Debtors and/or any former directors or officers of the Debtors other than advice directly relating to the preparation and filing of the Chapter 11 Cases (it being understood any prepetition advice to the Debtors relating to prepetition transactions between the Debtors and Beneficient shall not constitute advice directly relating to the preparation and filing of the Chapter 11 Cases); or (6) any Non-Released Party.

Entry of the Confirmation Order shall constitute the Bankruptcy Court's approval, pursuant to Bankruptcy Rule 9019, of the foregoing Debtor Release, which includes by reference each of the related provisions and definitions contained in the Plan, and further, shall constitute the Bankruptcy Court's finding that the Debtor Release is: (a) in exchange for the good and valuable consideration provided by the Released Parties, including, without limitation, the Released Parties' contributions to facilitating the Wind Down Transactions and implementing the Plan; (b) a good faith settlement and compromise of the Claims released by the Debtor Release; (c) in the best interests of the Debtors and all holders of Claims and Interests; (d) fair, equitable, and reasonable; (e) given and made after due notice and opportunity for hearing; and (f) a bar to any of the Debtors, the Wind Down Debtors, or the Debtors' Estates asserting any Claim or Cause of Action released pursuant to the Debtor Release.

D. *[RESERVED.]*

[RESERVED.]

E. *Exculpation.*

Except as otherwise expressly stated in this Plan or the Confirmation Order, as of the Effective Date, each Exculpated Party shall be deemed to be released and exculpated from any claim, obligation, Cause of Action, or liability for any Exculpated Claim, except for claims related to any act or omission that is determined in a Final Order to have constituted intentional breach of fiduciary duty, actual fraud, willful misconduct, or gross negligence, but in all respects each Debtor and each Exculpated Party shall be entitled to reasonably rely upon the advice of counsel with respect to their duties and responsibilities pursuant to the Plan. The Exculpated Parties have, and upon the Consummation of the Plan, shall be deemed to have, participated in good faith and in compliance with applicable law with regard to the restructuring of Claims and Interests in the Chapter 11 Cases and in connection with the Wind Down Transactions, the negotiation, formulation, or preparation of the Wind Down Documents or related agreements, instruments, or other documents (including, for the avoidance of doubt, providing any legal opinion requested by any Entity regarding any transaction, contract, instrument, document, or other agreement contemplated by the Plan or the reliance by any Released Party on the Plan or the Confirmation Order in lieu of such legal opinion) in connection with the Plan, and the solicitation of the Plan and distributions pursuant to the Plan and, therefore, are not, and on account of such distributions shall not be, liable at any time for the violation of any applicable law, rule, or regulation governing the solicitation of acceptances or rejections of the Plan or such distributions made pursuant to the Plan, except for claims related to any act or omission that is determined in a Final Order to have constituted intentional breach of fiduciary duty, actual fraud, willful

misconduct, or gross negligence. The Debtors and the Creditor Proponents agree that (1) neither the act itself of Filing or prosecuting a motion to approve a settlement of any Estate Causes of Action with Beneficient, any of its Affiliates or related parties, and/or any other Non-Released Party nor the act itself of Filing or prosecuting any objection to any such settlement in and of itself constitutes an intentional breach of fiduciary duty, and (2) any claims that the Debtors or the Creditor Proponents may seek to bring against any Exculpated Party shall be limited to any actions of such Exculpated Party solely after the date of execution of the Mediation Agreement; *provided* that any such claims must be Filed exclusively in the Bankruptcy Court and in accordance with the Federal Rules of Civil Procedures, and such claims shall be pled with specificity with respect to the who, what, when, where, and how of the alleged wrongful conduct.

F. Protections Against Discriminatory Treatment after the Effective Date.

In accordance with section 525 of the Bankruptcy Code, and consistent with paragraph 2 of Article VI of the United States Constitution, no Governmental Unit shall discriminate against any Wind Down Debtor, or any Entity with which a Wind Down Debtor has been or is associated (including the Wind Down Trustee), solely because such Wind Down Debtor was a Debtor under Chapter 11 of the Bankruptcy Code, may have been insolvent before the commencement of the Chapter 11 Cases (or during the Chapter 11 Cases but before such Debtor was granted or denied a discharge), or has not paid a debt that is dischargeable in the Chapter 11 Cases. For the avoidance of doubt, 28 U.S.C. § 959(b) shall apply.

G. Injunction.

Except as otherwise expressly provided in the Plan or the Confirmation Order or for obligations or distributions required to be paid pursuant to the Plan or the Confirmation Order, all Entities who have held, hold, or may hold claims that have been released pursuant to Article VIII hereof are permanently enjoined, from and after the Effective Date, from taking any of the following actions against, as applicable, the Debtors, the Released Parties, or the Exculpated Parties: (1) commencing or continuing in any manner any action or other proceeding of any kind on account of or in connection with or with respect to any of the claims or interests released hereunder; (2) enforcing, attaching, collecting, or recovering by any manner or means any judgment, award, decree, or order against such Entities on account or in connection with or with respect to any claims or interests released hereunder; (3) creating, perfecting, or enforcing any Lien or encumbrance of any kind against such Entities or the property of such Entities on account or in connection with or with respect to any claims or interests released hereunder; (4) asserting any right of setoff, subrogation, or recoupment of any kind against any obligation due from such Entities or against the property or the Estates of such Entities on account or in connection with or with respect to any claims or interests released hereunder, unless such holder has Filed a motion requesting the right to perform such setoff on or before the Effective Date, and notwithstanding an indication of a Claim or Interest or otherwise that such Holder asserts, has, or intends to preserve any right of setoff pursuant to applicable law or otherwise; and (5) commencing or continuing in any manner any action or other proceeding of any kind on account of or in connection with or with respect to any claims or interests released or settled pursuant to this Plan.

Upon entry of the Confirmation Order, all Holders of Claims and Interests and their respective current and former employees, agents, officers, directors, principals, and direct and indirect Affiliates shall be enjoined from taking any actions to interfere with the implementation or Consummation of this Plan. Except as otherwise set forth in the Confirmation Order, each Holder of an Allowed Claim or Allowed Interest, as applicable, by accepting, or being eligible to accept, distributions under this Plan shall be deemed to have consented to the injunction provisions set forth herein.

H. Recoupment.

In no event shall any Holder of Claims or Interests be entitled to recoup any Claim or Interest against any claim, right, or Cause of Action of the Debtors, the Wind Down Debtors, the Wind Down Trustee, the Wind Down Trust, or the Litigation Trust, as applicable, unless such Holder actually has performed such recoupment and provided notice thereof in writing to the Debtors on or before the Confirmation Date, notwithstanding any indication in any Proof of Claim or Interest or otherwise that such Holder asserts, has, or intends to preserve any right of recoupment.

I. Subordination Rights.

The classification and treatment of all Claims and Interests under the Plan shall conform to and with the respective contractual, legal, and equitable subordination rights of such Claims and Interests, and may only be modified upon entry of a Final Order approving or directing the settlement, compromise, release, and/or other alteration of any such rights.

K Document Retention.

On and after the Effective Date, the Wind Down Debtors, the Wind Down Trustee, the Wind Down Trust, and the Litigation Trust, as applicable, may maintain documents in accordance with the Wind Down Debtors' standard document retention policy, as may be altered, amended, modified, or supplemented by the Wind Down Debtors, Wind Down Trust, Wind Down Trustee, or the Litigation Trust, as applicable.

J. Ipso Facto and Similar Provisions Ineffective.

To the extent permitted by applicable law, any term of any prepetition policy, contract, or other obligation applicable to the Debtors shall be void and of no further force or effect to the extent that such policy, contract, or other obligation is conditioned on, creates an obligation as a result of, or gives rise to a right of any Entity based on: (1) the insolvency or financial condition of a Debtor; (2) the commencement of any of the Chapter 11 Cases; (3) either the Confirmation or Consummation of the Plan; or (4) any of the Wind Down Transactions.

K. Reimbursement or Contribution.

If the Bankruptcy Court disallows a Claim for reimbursement or contribution of an Entity pursuant to section 502(e)(1)(B) of the Bankruptcy Code, then to the extent that such Claim is contingent as of the time of allowance or disallowance, such Claim shall be forever disallowed and expunged notwithstanding section 502(j) of the Bankruptcy Code, unless before the

Confirmation Date: (1) such Claim has been adjudicated as non-contingent or (2) the relevant Holder of a Claim has Filed a non-contingent Proof of Claim on account of such Claim and a Final Order has been entered before the Confirmation Date determining such Claim as no longer contingent.

ARTICLE IX.
CONDITIONS PRECEDENT TO CONFIRMATION AND THE EFFECTIVE DATE

A. Conditions Precedent to the Effective Date.

It shall be a condition to Consummation that the following conditions shall have been satisfied or waived pursuant to the provisions of Article IX.C hereof:

- (a) the Bankruptcy Court shall have entered the Confirmation Order, subject to the Proponents' Consent Right, and such order shall have become a Final Order that has not been stayed, modified, or vacated on appeal, subject to the Debtors' right to waive any appeal period (with the reasonable consent of the Creditor Proponents);
- (b) the Debtors shall have assumed the D&O Liability Insurance Policies, which shall include, for the avoidance of doubt, policies that provide coverage for periods and were purchased prior to April 20, 2022;
- (c) the Debtors shall have obtained additional director and officer liability tail insurance coverage for the period from April 20, 2022 to the Effective Date, which insurance coverage must not terminate or otherwise reduce the coverage set forth in the existing D&O Liability Insurance Policies, the form and substance of which being subject to the Proponents' Consent Right;
- (d) the Vida Exit Financing Facility Documents shall have been executed, delivered, be in full force and effect (with all conditions precedent thereto having been satisfied or waived), and any amendments, modifications or supplements to the Vida Exit Financing Facility Documents that were Filed at Docket No. 975 shall be in form and substance subject to the Proponents' Consent Right;
- (e) the Investigations Committee shall have completed its independent investigation with respect to any releases granted pursuant to this Plan;
- (f) the Wind Down Trust Agreement shall have been executed and shall be in form and substance subject to the Proponents' Consent Right;
- (g) the Wind Down Budget shall have been delivered to the Creditor Proponents and shall be in form and substance subject to the Proponents' Consent Right;

- (h) the Wind Down Trust Assets shall have been transferred to the Wind Down Trust;
- (i) the Wind Down Trustee shall have accepted the appointment;
- (j) the Litigation Trust Agreement shall have been executed and shall be in form and substance subject to the Proponents' Consent Right;
- (k) the Litigation Trustee shall have been appointed and have accepted the appointment;
- (l) the Initial Litigation Trust Assets shall have been transferred to the Litigation Trust;
- (m) the New WDT Interests shall have been issued
- (n) the New WDT Documents shall be in form and substance subject to the Proponents' Consent Right;
- (o) any Plan Supplement documents, including any exhibits, schedules, amendments, modifications, or supplements thereto, not otherwise identified above in this Article IX.A, shall have been Filed and shall be in form and substance subject to the Proponents' Consent Right;
- (p) all governmental and material third party approvals and consents, including Bankruptcy Court approval, necessary in connection with the transactions contemplated by the Plan shall have been obtained, not be subject to unfulfilled conditions and be in full force and effect, and all applicable waiting periods shall have expired without any action being taken or threatened by any competent authority that would restrain, prevent, or otherwise impose materially adverse conditions on such transactions; *provided*, it being understood that any 1940 Act matters in connection with the Wind Down Trust shall be addressed as set forth in Article IV.A herein;
- (q) the Professional Fee Escrow Account shall have been funded with Cash in the amount of the aggregate Professional Fee Escrow Amount for all Professionals;
- (r) to the extent of Cash distributions would apply to any such Disputed Claims, and to the extent that Cash is available, the Disputed Claims Reserve shall have been established and funded; and
- (s) any other corporate or related actions necessary or advisable in the reasonable business judgment of the Debtors and subject to the Proponents' Consent Right for the Plan to become effective shall have been taken.

B. Effect of Non-Occurrence of Conditions Precedent to Consummation.

If the Effective Date does not occur, then: (1) this Plan will be null and void in all respects; and (2) nothing contained in the Plan or the Disclosure Statement shall (a) constitute a waiver or release of any Claims, Interests, or Causes of Action by an Entity, (b) prejudice in any manner the rights of any Debtor or any other Entity, (c) constitute an admission, acknowledgment, offer, or undertaking of any sort by any Debtor or any other Entity, or (d) constitute an Allowance of any Claim or Interest.

C. Waiver of Conditions Precedent.

The conditions to Confirmation and Consummation set forth in Article IX of this Plan, other than the condition that the Confirmation Order has been entered by the Bankruptcy Court, may be waived only by prior written consent of the Debtors and the Creditor Proponents (subject to the Proponents' Consent Rights), without notice, leave, or order of the Bankruptcy Court or any formal action other than proceedings to confirm or consummate the Plan. Upon the occurrence of all the conditions to Confirmation and Consummation set forth in Article IX of this Plan, the Debtor shall immediately declare the Effective Date. The failure of the Debtors, the Wind Down Debtors, the Wind Down Trustee, or the Creditor Proponents, as applicable, to exercise any of the foregoing rights shall not be deemed a waiver of any other rights, and each such right shall be deemed an ongoing right that may be asserted at any time.

**ARTICLE X.
MODIFICATION, REVOCATION, OR WITHDRAWAL OF THE PLAN**

A. Modification and Amendments.

Except as otherwise specifically provided in the Plan, the Debtors reserve the right to modify this Plan subject to the Proponents' Consent Right or whether materially or immaterially, and seek Confirmation, in each instance, to the extent permitted under the Bankruptcy Code. Subject to certain restrictions and requirements set forth in section 1127 of the Bankruptcy Code and Bankruptcy Rule 3019 and those restrictions on modifications set forth in the Plan, the Debtors expressly reserve their rights to alter, amend, or modify materially the Plan, subject to the Proponents' Consent Right, one or more times, after Confirmation, and, to the extent necessary, may initiate proceedings in the Bankruptcy Court, subject to the Proponents' Consent Right, to so alter, amend, or modify the Plan, or remedy any defect or omission, or reconcile any inconsistencies in the Plan, the Disclosure Statement, or the Confirmation Order, in such matters as may be necessary to carry out the purposes and intent of this Plan. Notwithstanding the foregoing and for the avoidance of doubt, any such modification or amendments pursuant to this Article X.A shall be consistent in all material respects with the Mediation Agreement. Any such modification or supplement shall be considered a modification of this Plan and shall be made in accordance with Article X of this Plan.

B. Effect of Confirmation on Modifications.

Entry of a Confirmation Order shall mean that all modifications or amendments to this Plan occurring after the solicitation thereof and before the Confirmation Date are approved pursuant to

section 1127(a) of the Bankruptcy Code and do not require additional disclosure or resolicitation under Bankruptcy Rule 3019.

C. Revocation or Withdrawal of the Plan.

The Debtors reserve the right, with the consent of the Creditor Proponents, to revoke or withdraw the Plan with respect to one or more of the Debtors before the Confirmation Date or the Effective Date and to File subsequent plans under chapter 11 of the Bankruptcy Code. If the Debtors revoke or withdraw the Plan with respect to any Debtor, or if Confirmation or Consummation does not occur with respect to any Debtor, then: (1) the Plan with respect to such Debtor shall be null and void in all respects; (2) any settlement or compromise embodied in the Plan with respect to such Debtor (including the fixing or limiting to an amount certain of any Claim or Interest or Class of Claims or Interests), assumption and assignment or rejection of Executory Contracts or Unexpired Leases effected by the Plan with respect to such Debtor, and any document or agreement executed pursuant to the Plan with respect to such Debtor, shall be deemed null and void; and (3) nothing contained in the Plan with respect to such Debtor shall (a) constitute a waiver or release of any Claims or Interests, (b) prejudice in any manner the rights of the Debtors or any other Entity, or (c) constitute an admission, acknowledgement, offer, or undertaking of any sort by the Debtors or any other Entity.

Notwithstanding any provision of this Article X or otherwise in this Plan to the contrary, the Debtors and any of the Debtors' directors, managers, and officers shall maintain the right to exercise their fiduciary duties in accordance with applicable law.

**ARTICLE XI.
RETENTION OF JURISDICTION**

Notwithstanding the entry of the Confirmation Order and the occurrence of the Effective Date, on and after the Effective Date, the Bankruptcy Court shall retain exclusive jurisdiction over the Chapter 11 Cases and all matters, arising out of, or related to, the Chapter 11 Cases and the Plan pursuant to sections 105 and 1142 of the Bankruptcy Code, including jurisdiction to:

1. allow, disallow, determine, liquidate, classify, estimate, or establish the priority, Secured or unsecured status, or amount of any Claim or Interest, including the resolution of any request for payment of any Claim or Interest and the resolution of any and all objections to the Secured or unsecured status, priority, amount, or allowance of Claims or Interests;
2. decide and resolve all matters related to the granting and denying, in whole or in part, any applications for allowance of compensation or reimbursement of expenses to Professionals authorized pursuant to the Bankruptcy Code or the Plan;
3. resolve any matters related to: (a) the assumption, assumption and assignment, or rejection of any Executory Contract or Unexpired Lease to which a Debtor is party or with respect to which a Debtor may be liable in any manner and to hear, determine, and, if necessary, liquidate, any Claims arising therefrom, including Claims related to the rejection of an Executory Contract or Unexpired Lease, Cure Amounts pursuant to section 365 of the Bankruptcy Code, or any other matter related to such Executory Contract or Unexpired Lease; (b) any potential contractual obligation under any Executory Contract or Unexpired Lease that is assumed and/or assigned;

(c) the Debtors amending, modifying, or supplementing, after the Effective Date, pursuant to Article V of the Plan, any Executory Contracts or Unexpired Leases to the Schedule of Assumed Executory Contracts and Unexpired Leases or otherwise; and (d) any dispute regarding whether a contract or lease is or was executory or expired;

4. ensure that distributions to Holders of Allowed Claims and Allowed Interests are accomplished pursuant to the provisions of the Plan and adjudicate any and all disputes arising from or relating to distributions under the Plan or any transactions contemplated therein;

5. adjudicate, decide, or resolve any motions, adversary proceedings, contested or litigated matters, and any other matters, and grant or deny any applications involving a Debtor that may be pending on the Effective Date;

6. adjudicate, decide, or resolve any and all matters related to the Retained Causes of Action;

7. enter and implement such orders as may be necessary or appropriate to execute, implement, or consummate the provisions of the Plan and all contracts, instruments, releases, indentures, and other agreements or documents created in connection with the Plan or the Disclosure Statement;

8. enforce any order for the sale of property pursuant to sections 361, 1123, or 1146(a) of the Bankruptcy Code;

9. grant any consensual request to extend the deadline for assuming or rejecting Unexpired Leases pursuant to section 365(d)(4) of the Bankruptcy Code;

10. resolve any cases, controversies, suits, disputes, or Causes of Action that may arise in connection with the Consummation, interpretation, or enforcement of the Plan or any Entity's obligations incurred in connection with the Plan;

11. issue injunctions, enter and implement other orders, or take such other actions as may be necessary or appropriate to restrain interference by any Entity with Consummation or enforcement of the Plan;

12. resolve any cases, controversies, suits, disputes, or Causes of Action with respect to the settlements, compromises, releases, injunctions, exculpations, and other provisions contained in Article VIII of this Plan and enter such orders as may be necessary or appropriate to implement such releases, injunctions, and other provisions;

13. resolve any cases, controversies, suits, disputes, or Causes of Action with respect to the repayment or return of distributions and the recovery of additional amounts owed by the Holder of a Claim or Interest for amounts not timely repaid pursuant to Article VI.E of this Plan;

14. enter and implement such orders as are necessary or appropriate if the Confirmation Order is for any reason modified, stayed, reversed, revoked, or vacated;

15. determine any other matters that may arise in connection with or relate to the Plan, the Disclosure Statement, the Confirmation Order, the Wind Down Trust Agreement, the Litigation Trust Agreement, the Vida Exit Financing Facility Documents, or any contract, instrument, release, indenture, or other agreement or document created in connection with the Plan or the Disclosure Statement;

16. decide and resolve all matters related to the issuance of New WDT Interests;

17. consider any modifications of the Plan, to cure any defect or omission, or to reconcile any inconsistency in any Bankruptcy Court order, including the Confirmation Order;

18. determine requests for the payment of Claims and Interests entitled to priority pursuant to section 507 of the Bankruptcy Code;

19. hear and determine disputes arising in connection with the interpretation, implementation, or enforcement of the Plan, or the Confirmation Order, including disputes arising under agreements, documents, or instruments executed in connection with the Plan;

20. hear and determine matters concerning state, local, and federal taxes in accordance with sections 346, 505, and 1146 of the Bankruptcy Code;

21. hear and determine matters concerning section 1145 of the Bankruptcy Code;

22. hear and determine all disputes involving the existence, nature, or scope of the Debtor Release, including any dispute relating to any liability arising out of the termination of employment or the termination of any employee or retiree benefit program, regardless of whether such termination occurred before or after the Effective Date;

23. enforce all orders previously entered by the Bankruptcy Court;

24. hear any other matter not inconsistent with the Bankruptcy Code;

25. enter an order concluding or closing the Chapter 11 Cases; and

26. Enforce the injunction, release, and exculpation provisions set forth in Article VIII hereof.

ARTICLE XII. MISCELLANEOUS PROVISIONS

A. Immediate Binding Effect.

Subject to Article IX of this Plan and notwithstanding Bankruptcy Rules 3020(e), 6004(h), or 7062 or otherwise, upon the occurrence of the Effective Date, the Plan and the Plan Supplement shall be immediately effective and enforceable and deemed binding upon the Debtors, any and all Holders of Claims or Interests (irrespective of whether the Holders of such Claims or Interests accepted or rejected the Plan), all Entities that are parties to or are subject to the settlements, compromises, releases, and injunction described in the Plan, each Entity acquiring property under

the Plan, and any and all non-Debtor parties to Executory Contracts and Unexpired Leases with the Debtors. All Claims against and Interests in the Debtors shall be fixed, adjusted, or compromised, as applicable, pursuant to the Plan regardless of whether any Holder of a Claim or Interest has voted on the Plan.

B. Additional Documents.

On or before the Effective Date, the Debtors may File with the Bankruptcy Court such agreements and other documents as may be necessary or appropriate to effectuate and further evidence the terms and conditions of the Plan. The Debtors, all Holders of Claims or Interests receiving distributions pursuant to the Plan, and all other parties in interest shall, from time to time, prepare, execute, and deliver any agreements or documents and take any other actions as may be necessary or advisable to effectuate the provisions and intent of the Plan.

C. Payment of Statutory Fees.

All fees payable under section 1930 of chapter 123 of title 28 of the United States Code shall be paid on the Effective Date, or as soon as practicable thereafter, by the Debtors or Wind Down Debtors. Quarterly fees owed to the U.S. Trustee shall be paid when due in accordance with applicable law and the Debtors and Wind Down Debtors shall continue to file reports to show the calculation of such fees for the Debtors' Estates until the Chapter 11 Cases are closed under section 350 of the Bankruptcy Code. Each and every one of the Debtors shall remain obligated to pay quarterly fees to the U.S. Trustee until the earliest of that particular Debtor's case is closed, dismissed, or converted to a case under chapter 7 of the Bankruptcy Code.

D. Dissolution of the Bondholder Committee.

On the Effective Date, any statutory committee appointed in the Chapter 11 Cases (including the Bondholder Committee) shall dissolve and members thereof shall be released and discharged from all rights and duties from or related to the Chapter 11 Cases; *provided, however*, that following the Effective Date, the Bondholder Committee will continue in existence and have standing and a right to be heard for the following limited purposes: (1) adjudication of any final fee applications Filed pursuant to sections 330 and 331 of the Bankruptcy Code in accordance with the Plan; and (2) any (a) appeals of the Confirmation Order, and (b) any appeals, prosecution, or defense of any Causes of Action or proceedings with respect to which the Bondholder Committee is a party as of the Effective Date. Following the completion of the Bondholder Committee's remaining duties set forth above, the Bondholder Committee will be dissolved, and the retention or employment of the Bondholder Committee's respective attorneys, accountants and other agents will terminate without further notice to, or action by, any Entity. The Wind Down Debtors shall be responsible for fees incurred in connection with the foregoing purposes only and shall be paid in the ordinary course from the Professional Fee Escrow Account without need for Bankruptcy Court approval.

E. Reservation of Rights.

The Plan shall have no force or effect unless the Bankruptcy Court shall enter the Confirmation Order. Neither the Plan, any statement or provision contained in the Plan, nor any action taken or not taken by any Debtor, any Wind Down Debtor, the Wind Down Trustee, the

Wind Down Trust, or the Litigation Trust with respect to the Plan or any other Wind Down Document shall be or shall be deemed to be an admission or waiver of any rights of any such parties with respect to the Holders of Claims or Interests before the Effective Date.

F. Successors and Assigns.

The rights, benefits, and obligations of any Entity named or referred to in the Plan or the Confirmation Order shall be binding on, and shall inure to the benefit of any heir, executor, administrator, successor, or assign, Affiliate, officer, director, manager, trustee, agent, representative, attorney, beneficiaries, or guardian, if any, of each Entity.

G. Service of Documents.

Any pleading, notice, or other document required by the Plan to be served on or delivered to the Debtors shall be served on:

GWG Holdings, Inc.
Attn.: Jeffrey S. Stein
325 N. St. Paul Street, Suite 2650
Dallas, Texas 7520
E-mail address: jstein@steinadvisorsllc.com

with copies to:

Jackson Walker LLP
1401 McKinney Street, Suite 1900
Houston, Texas 77010
Attention: Kristhy M. Peguero and Matthew D. Cavanaugh
Email addresses: kpeguero@jw.com, mcavanaugh@jw.com

-and-

Mayer Brown LLP
700 Louisiana Street, Suite 3400
Houston, Texas 77002-3000
Attention: Charles S. Kelley
Email address: ckelley@mayerbrown.com

-and-

Mayer Brown LLP
71 South Wacker Drive
Chicago, Illinois 60606
Attention: Thomas S. Kiriakos and Louis Chiappetta
Email addresses: tkiriakos@mayerbrown.com, lchiappetta@mayerbrown.com

-and-

Mayer Brown LLP
1221 Avenue of the Americas
New York, New York 10020-1001
Attention: Adam Paul and Lucy Kweskin
Email addresses: apaul@mayerbrown.com, lkweskin@mayerbrown.com

After the Effective Date, the Wind Down Debtors and the Wind Down Trustee have authority to send a notice to Entities that, in order to continue to receive documents pursuant to Bankruptcy Rule 2002, such Entity must File a renewed request to receive documents pursuant to Bankruptcy Rule 2002. After the Effective Date, the Wind Down Debtors and the Wind Down Trustee are authorized to limit the list of Entities receiving documents pursuant to Bankruptcy Rule 2002 to those Entities who have Filed such renewed requests.

H. Enforcement of Confirmation Order.

On and after the Effective Date, the Debtors, the Wind Down Debtors, the Wind Down Trustee, the Wind Down Trust, and the Litigation Trust, as applicable, shall be entitled to enforce the terms of the Confirmation Order and the Plan.

I. Term of Injunctions or Stays.

Unless otherwise provided in the Plan or in the Confirmation Order, all injunctions or stays in effect in the Chapter 11 Cases pursuant to sections 105 or 362 of the Bankruptcy Code or any order of the Bankruptcy Court, and extant on the Confirmation Date (excluding any injunctions or stays contained in the Plan or the Confirmation Order) shall remain in full force and effect until the Effective Date. All injunctions or stays contained in the Plan or the Confirmation Order (including the injunction set forth in Article VIII.G of this Plan) shall remain in full force and effect in accordance with their terms.

J. Entire Agreement.

Except as specifically set forth herein, the Plan, the Confirmation Order, and the Plan Supplement supersede all previous and contemporaneous negotiations, promises, covenants, agreements, understandings, and representations made in these Chapter 11 Cases, all of which have become merged and integrated into the Plan.

K. Votes Solicited in Good Faith.

Upon entry of the Confirmation Order, the Debtors will be deemed to have solicited votes on the Plan in good faith and in compliance with section 1125(g) of the Bankruptcy Code, and pursuant to section 1125(e) of the Bankruptcy Code, the Debtors and each of their respective Affiliates, agents, representatives, members, principals, shareholders, officers, directors, managers, employees, advisors, and attorneys will be deemed to have participated in good faith and in compliance with the Bankruptcy Code in the offer, issuance, sale, and purchase of securities offered and sold under the Plan and any previous plan, and, therefore, neither any of such parties or individuals or the Wind Down Debtors will have any liability for the violation of any applicable

law, rule, or regulation governing the solicitation of votes on the Plan or the offer, issuance, sale, or purchase of the securities offered and sold under the Plan and any previous plan.

L. Exhibits.

All exhibits and documents included in the Plan Supplement are incorporated into and are a part of the Plan as if set forth in full in the Plan. After the exhibits and documents are Filed, copies of such exhibits and documents shall be available upon written request to the Debtors' counsel at the address above or by downloading such exhibits and documents from the Debtors' restructuring website at <http://www.donlinrecano.com/clients/gwg> or the Bankruptcy Court's website at www.txs.uscourts.gov.

M. Nonseverability of Plan Provisions.

If, before Confirmation, any term or provision of the Plan is held by the Bankruptcy Court to be invalid, void, or unenforceable, the Bankruptcy Court, at the request of the Debtors, shall have the power to alter and interpret such term or provision to make it valid or enforceable to the maximum extent practicable, consistent with the original purpose of the term or provision held to be invalid, void, or unenforceable, and such term or provision shall then be applicable as altered or interpreted. Notwithstanding any such holding, alteration, or interpretation, the remainder of the terms and provisions of the Plan will remain in full force and effect and will in no way be affected, impaired, or invalidated by such holding, alteration, or interpretation. The Confirmation Order shall constitute a judicial determination and shall provide that each term and provision of the Plan, as it may have been altered or interpreted in accordance with the foregoing, is: (1) valid and enforceable pursuant to its terms; (2) integral to the Plan and may not be deleted or modified without the consent of the Debtors; and (3) nonseverable and mutually dependent.

N. Closing of Chapter 11 Cases.

The Wind Down Trustee shall, promptly after the full administration of the Chapter 11 Cases, File with the Bankruptcy Court all documents required by Bankruptcy Rule 3022 and any applicable order of the Bankruptcy Court to close the Chapter 11 Cases; *provided* that, following the Effective Date, the Wind Down Trustee may seek to close certain of the Chapter 11 Cases that have been fully administered, notwithstanding the fact that the reconciliation of Claims is ongoing.

O. Creditor Default.

An act or omission by a Holder of a Claim or an Interest in contravention of the provisions of this Plan shall be deemed an event of default under this Plan and upon such an event of default, the Wind Down Trust may pursue any appropriate remedies under applicable law.

P. Waiver or Estoppel.

Each Holder of a Claim or an Interest shall be deemed to have waived any right to assert any argument, including the right to argue that its Claim or Interest should be Allowed in a certain amount, in a certain priority, Secured or not subordinated by virtue of an agreement made with the Debtors or their counsel, or any other Entity, if such agreement was not disclosed in the Plan, the Disclosure Statement, or papers Filed with the Bankruptcy Court before the Confirmation Date.

[Remainder of page intentionally left blank.]

Houston, Texas
April 20, 2023

Respectfully Submitted,

/s/ Jeffrey S. Stein

Jeffrey S. Stein as Chief Restructuring Officer,
President, Chief Executive Officer and
Independent Director of GWG Holdings, Inc.

/s/ Kade Baird

Kade Baird, as designated representative of Bank
of Utah, as Indenture Trustee and solely in its
capacity as Chair of the Official Committee of
Bondholders of GWG Holdings, Inc., *et al.*

/s/ Richard S. Schmidt

Richard S. Schmidt, as Restructuring Manager of
L Bond Management, LLC

JACKSON WALKER LLP

Kristhy M. Peguero (TX Bar No. 24102776)
Matthew D. Cavanaugh (TX Bar No. 24062656)
1401 McKinney Street, Suite 1900
Houston, TX 77010
Telephone: (713) 752-4200
Email: kpeguero@jw.com
mcaavanaugh@jw.com

Co-Counsel for the Debtors and Debtors in Possession

MAYER BROWN LLP

Charles S. Kelley (TX Bar No. 11199580)
700 Louisiana Street, Suite 3400
Houston, TX 77002-2730
Telephone: (713) 238-3000
Email: ckelley@mayerbrown.com

-and-

Thomas S. Kiriakos (admitted *pro hac vice*)
Louis S. Chiappetta (admitted *pro hac vice*)
Jamie R. Netznik (admitted *pro hac vice*)
Lisa Holl Chang
Joshua R. Gross (admitted *pro hac vice*)
Jade Edwards
71 S. Wacker Drive
Chicago, IL 60606
Telephone: (312) 782-0600
Email: tkiriakos@mayerbrown.com
lchiappetta@mayerbrown.com
jnetznik@mayerbrown.com
lhollchang@mayerbrown.com
jgross@mayerbrown.com
jmedwards@mayerbrown.com

-and-

Adam C. Paul (admitted *pro hac vice*)
Lucy F. Kweskin (admitted *pro hac vice*)
Ashley Anglade
1221 Avenue of the Americas
New York, NY 10020-1001
Telephone: (212) 506-2500
Email: apaul@mayerbrown.com
lkweskin@mayerbrown.com
aanglade@mayerbrown.com

Counsel for the Debtors and Debtors in Possession

PORTER HEDGES LLP

Eric M. English (TX Bar No. 24062714)
M. Shane Johnson (TX Bar No. 24083263)
1000 Main Street, 36th Floor
Houston, Texas 77002-2764
Telephone: (713) 226-6000
Facsimile: (713) 226-6248
eenglish@porterhedges.com
sjohnson@porterhedges.com

*Counsel to Creditor Proponent, the Official
Committee of Bondholders of GWG Holdings,
Inc., et al.*

**AKIN GUMP STRAUSS HAUER & FELD
LLP**

Lacy M. Lawrence
State Bar No. 24055913; S.D. Tex. No. 995675
2300 N. Field St., Suite 1800
Dallas, TX 75201
Telephone: (214) 969-2800
Facsimile: (214) 969-4343
Email: llawrence@akingump.com

-and-

Michael S. Stamer (admitted *pro hac vice*)
Abid Qureshi (admitted *pro hac vice*)
Jason P. Rubin (admitted *pro hac vice*)
One Bryant Park
New York, New York 10036
Telephone: (212) 872-1000
Facsimile: (212) 872-1002
Email: mstamer@akingump.com
aqureshi@akingump.com
jrubin@akingump.com

-and-

Scott L. Alberino (admitted *pro hac vice*)
Benjamin L. Taylor (admitted *pro hac vice*)
Robert S. Strauss Tower
2001 K Street, N.W.
Washington, DC 20006-1037
Phone: (202) 887-4000
Fax: (202) 887-4288
Email: salberino@akingump.com
taylorb@akingump.com

*Counsel to Creditor Proponent, the Official
Committee of Bondholders of GWG Holdings,
Inc., et al.*

OKIN ADAMS LLP

Matthew S. Okin (TX Bar No. 00784695)
David L. Curry, Jr. (TX Bar No. 24065107)
Edward A. Clarkson, III (TX Bar No. 24059118)
1113 Vine Street, Suite 240
Houston, Texas 77002
Tel: (713) 228-4100
Fax: (346) 247-7158
Email: mokin@okinadams.com
dcurry@okinadams.com
eclarkson@okinadams.com

*Counsel to Creditor Proponent, L Bond
Management, LLC*

**KATTEN MUCHIN ROSENMAN
LLP**

Steven J. Reisman (*pro hac vice*)
Cindi M. Giglio (*pro hac vice*)
Marc B. Roitman (*pro hac vice*)
Jerry L. Hall (*pro hac vice*)
50 Rockefeller Plaza
New York, NY 10020
Telephone: (212) 940-8800
Email: sreisman@katten.com
cgiglio@katten.com
marc.roitman@katten.com
jerry.hall@katten.com

-and-

Daniel Barnowski (*pro hac vice*)
2900 K Street NW, Suite 200
Washington, DC 20007
Telephone: (202) 625-3500
Email: dan.barnowski@katten.com

*Counsel to Jeffrey S. Stein and Anthony
R. Horton, in their capacity as members
of the Investigations Committee and
Special Committee of the Board of
Directors of GWG Holdings, Inc.*

Exhibit B

Disclosure Statement Order

[separately filed]

ENTERED

April 21, 2023

Nathan Ochsner, Clerk

**IN THE UNITED STATES BANKRUPTCY COURT
FOR THE SOUTHERN DISTRICT OF TEXAS
HOUSTON DIVISION**

In re:)	
)	Chapter 11
)	
GWG Holdings, Inc., <i>et al.</i> , ¹)	Case No. 22-90032 (MI)
)	
Debtors.)	(Jointly Administered)
)	Re: Docket No. 1423

ORDER (I) APPROVING THE DISCLOSURE STATEMENT; (II) APPROVING THE SOLICITATION PROCEDURES; (III) APPROVING THE FORM OF BALLOTS AND NOTICES; (IV) APPROVING CERTAIN DATES AND DEADLINES IN CONNECTION WITH THE SOLICITATION AND CONFIRMATION OF THE PLAN; AND (V) SCHEDULING A HEARING ON CONFIRMATION OF THE PLAN

The debtors and debtors in possession (collectively, the “Debtors”) in the above-captioned chapter 11 cases (the “Chapter 11 Cases”) filed their *Motion for Entry of an Order (I) Approving the Adequacy of the Disclosure Statement; (II) Approving the Solicitation Procedures; (III) Approving the Forms of Ballots and Notices; (IV) Approving the Confirmation Timeline; and (V) Granting Related Relief* (the “Motion”),² seeking, among other things, approval of the *Disclosure Statement for the Debtors’ Second Amended Joint Chapter 11 Plan* [Docket No. **1676**] (as may be amended, supplemented, or modified, the “Disclosure Statement”) and approval of procedures for the solicitation of, among other things, votes to accept or reject the *Debtors’ Second Amended Joint Chapter 11 Plan* [Docket No. **1678**] (as may be amended, supplemented, or modified, the “Plan”). The Court has considered the Motion and finds that it has jurisdiction over this matter

¹ The Debtors in these chapter 11 cases, along with the last four digits of each Debtor’s federal tax identification number, are: GWG Holdings, Inc. (2607); GWG Life, LLC (6955); GWG Life USA, LLC (5538) GWG DLP Funding IV, LLC (2598); GWG DLP Funding VI, LLC (6955) and GWG DLP Funding Holdings VI, LLC (6955). The location of Debtor GWG Holdings, Inc.’s principal place of business and the Debtors’ service address is 325 N. St. Paul Street, Suite 2650, Dallas, TX 75201. Further information regarding the Debtors and these chapter 11 cases is available at the website of the Debtors’ claims and noticing agent: <https://donlinrecano.com/gwg>.

² Unless otherwise indicated, capitalized terms used but not defined herein shall the meanings ascribed to such terms in the Motion.

pursuant to 28 U.S.C. § 1334; this is a core proceeding pursuant to 28 U.S.C. § 157(b)(2); and venue of the Chapter 11 Cases in this district is proper pursuant to 28 U.S.C. §§ 1408 and 1409. The Court further finds that the Debtors provided appropriate notice of the Motion and the opportunity for a hearing on the Motion under the circumstances. Upon considering the Motion and statements presented at a hearing before the Court, if any (the “Hearing”), the Court has determined that the legal and factual bases set forth in the Motion and at the Hearing establish just cause for the relief granted herein and, after due deliberation and sufficient cause appearing therefor, IT IS ORDERED THAT:

A. Approval of the Disclosure Statement

1. The Disclosure Statement attached to this order (this “Order”) as **Exhibit 1** is approved as containing adequate information in accordance with section 1125 of the Bankruptcy Code.

B. Approval of the Confirmation Timeline

2. The Debtors’ request for a Confirmation Hearing on Confirmation of the Plan, and the following Confirmation Timeline, are hereby approved:

Event	Date	Description
Voting Record Date	February 24, 2023	Date for determining: (i) which Holders of Claims and Interests in the Voting Classes are entitled to vote to accept or reject the Plan; and (ii) whether Claims or Interests have been properly assigned or transferred to an assignee under Bankruptcy Rule 3001(e) such that the assignee or transferee, as applicable, can vote to accept or reject the Plan as the Holder of such Claims or Interests (the “ <u>Voting Record Date</u> ”).

Event	Date	Description
Solicitation Deadline	April 28, 2023	Deadline for distributing Solicitation Packages, including Ballots, to Holders of Claims and Interests entitled to vote to accept or reject the Plan (the “ <u>Solicitation Deadline</u> ”).
Publication Notice Deadline	April 28, 2023	Deadline for the Debtors to publish the Confirmation Hearing Notice in a format modified for publication (the “ <u>Publication Notice Deadline</u> ”).
Claim Solicitation Objection Deadline	May 24, 2023	Date by which objections to Proofs of Claim must be filed for the objected-to portion of such Proofs of Claim to be excluded from solicitation and ballot tabulation (the “ <u>Claim Solicitation Objection Deadline</u> ”).
Plan Supplement Filing Deadline	May 24, 2023	Deadline for the Debtors to file the Plan Supplement (the “ <u>Plan Supplement Filing Deadline</u> ”).
Assumption Notice Service Deadline	May 30, 2023	Deadline for the Debtors to serve the Assumption Notices upon the applicable counterparties to the executory contracts and unexpired leases that will be assumed pursuant to the Plan (the “ <u>Assumption Notice Service Deadline</u> ”).
Voting Deadline	May 31, 2023, at 4:00 p.m., prevailing Central Time	Deadline for Donlin, Recano & Company, Inc. (the “ <u>Solicitation Agent</u> ”) to actually receive properly executed and completed Ballots from all Holders of Claims and Interests entitled to vote or their Nominees (defined below) (if applicable) (the “ <u>Voting Deadline</u> ”).

Event	Date	Description
Confirmation Objection Deadline	May 31, 2023, at 11:59 p.m., prevailing Central Time	Deadline for parties in interest to file objections to Confirmation of the Plan (the “ <u>Confirmation Objection Deadline</u> ”).
Deadline to file Voting Report	June 12, 2023	Deadline for the Debtors to file the report tabulating the voting on the Plan (the “ <u>Voting Report Deadline</u> ”).
Confirmation Hearing	June 15, 2023, at 1:30 p.m., prevailing Central Time	Date of the Confirmation Hearing at which the Court will consider Confirmation of the Plan.

C. Approval of the Procedures for Filing Objections to Confirmation of the Plan

3. Objections to Confirmation of the Plan must (a) be in writing; (b) conform to the Bankruptcy Rules, the Bankruptcy Local Rules, and any orders of the Court; (c) state the name, address, phone number, and e-mail address of the objecting party and the amount and nature of the Claim or Interest of such entity, if any; (d) state, with particularity, the legal and factual basis for the objection and, if practicable, a proposed modification to the Plan (or related materials) that would resolve such objection; and (e) be filed with the Court on or before the Confirmation Objection Deadline. Objections that fail to comply with this Order will not be considered by the Court.

D. Approval of the Solicitation Procedures

4. The Solicitation Procedures, substantially in the form attached to this Order as Exhibit 3, are approved.

5. The Solicitation Agent is authorized to assist the Debtors in (a) distributing the Solicitation Packages, (b) receiving, tabulating, and reporting on Ballots cast to accept or reject the Plan by Holders of Claims and Interests, (c) responding to inquiries from Holders of Claims or Interests and other parties in interest relating to the Plan and the Disclosure Statement, the Ballot, the Solicitation Packages, and all other related documents and matters related thereto, including the procedures and requirements for voting to accept or reject the Plan and for objecting to the Plan, (d) soliciting votes on the Plan, and (e) if necessary, contacting creditors and equity holders regarding the Plan. The Solicitation Agent may, but is not obligated to, contact parties that submit incomplete or otherwise deficient ballots to make a reasonable effort to cure such deficiencies.

6. The Solicitation Agent is also authorized to accept Ballots via electronic online transmission through a customized online balloting portal on the Debtors' case website maintained by the Solicitation Agent ("E-Ballot") or through electronic mail, in each case subject to the Solicitation Procedures. Parties entitled to vote through E-Ballot may cast an electronic Ballot and electronically sign and submit the Ballot instantly by utilizing E-Ballot and parties entitled to vote through electronic mail may submit their Ballot to GWGVote@donlinrecano.com. The encrypted data and audit trail created by such electronic submissions will become part of the record of any Ballot submitted in this manner and the creditor's electronic signature will be deemed to be immediately legally valid and effective. Ballots submitted via the customized online balloting portal or electronic mail shall be deemed to contain an original signature. Ballots submitted by facsimile or other unauthorized means of transmission shall not be counted.

7. To the extent that any a bank, broker, securities intermediary, registered investment advisor, or other nominee, or an agent of any of the foregoing (each, a "Nominee") receives a Solicitation Package on behalf of a Holder, such Nominee shall undertake commercially

reasonable efforts to ensure timely receipt of the full Solicitation Package, including the Bondholder Summary, by the Holder. No Nominee shall vote on the Plan on behalf of any Holder unless such Nominee is expressly authorized in writing by the Holder under applicable law to vote on a chapter 11 plan on such Holder's behalf. The Nominee shall provide evidence of such written authorization if requested by the Debtors.

8. For the avoidance of doubt, (i) the Debtors and the Solicitation Agent shall not distribute or cause to be distributed Solicitation Packages (or any Ballots or E-Ballots) to the Indenture Trustee for transmission to Holders of Bondholder Claims, and (ii) the Indenture Trustee shall not be responsible for the distribution of Solicitation Packages (or any portion thereof) or the distribution, completion, tabulation, or return of any Ballots or E-Ballots with respect to any Holders of Bondholder Claims.

E. Approval of the Contents and Distribution of the Solicitation Packages

9. The Solicitation Packages shall include the following materials (which, for the avoidance of doubt, shall not include printed copies of, or other physical or digital media containing, the Plan and the Disclosure Statement), the forms of each of which are hereby approved:

- a. the Solicitation Procedures (which will include links to the Order, Plan, and Disclosure Statement);
- b. the applicable Ballot(s);
- c. the Confirmation Hearing Notice;
- d. with respect to holders of Bonds, a plain-English summary of the treatment of Bondholder Claims substantially in the form filed as Docket No. 1677 (the "Bondholder Summary"); and
- e. any additional materials that the Court has ordered to be made available.

10. The Solicitation Packages provide the Holders of Claims and Interests entitled to vote on the Plan with adequate information to make informed decisions with respect to voting on the Plan in accordance with Bankruptcy Rules 2002(b) and 3017(d), the Bankruptcy Code, and the Bankruptcy Local Rules. The procedures for distributing the Solicitation Packages as set forth in the Motion and the Solicitation Procedures satisfy the requirements of the Bankruptcy Code and the Bankruptcy Rules and are approved.

11. The Debtors shall distribute or cause to be distributed Solicitation Packages to all entities who, as of the Voting Record Date, are entitled to vote to accept or reject the Plan as soon as practicable after entry of this Order, but in no event later than the Solicitation Deadline set forth above. The Debtors will also provide complete Solicitation Packages (excluding the Ballots) to the U.S. Trustee and all other parties on the Master Service List not otherwise receiving Solicitation Packages for informational purposes only. Additionally, no later than the Solicitation Deadline, the Debtors shall distribute or cause to be distributed to Beneficial Holders of Bonds whose Bonds are held through a Nominee and who filed a Proof of Claim with respect to such Bonds a notice substantially in the form attached hereto as **Exhibit 7**, the form of which is hereby approved. Additionally, the members of the Ad Hoc Committee of Broker/Dealers are authorized to distribute to their clients who hold investments in the Debtors a letter encouraging such clients to vote to accept the Plan, substantially in the form attached hereto as **Exhibit 8** (the “AHC Letter”), the form of which is hereby approved. The Debtors also may elect to include the AHC Letter in Solicitation Packages (or otherwise distribute the AHC Letter) in their sole discretion.

12. The Debtors are authorized, but not directed, to distribute the Confirmation Hearing Notice as a separate mailing from the remaining documents included in the Solicitation Package.

If the Debtors mail the Confirmation Hearing Notice separately, the Debtors are not required to include an additional copy of the Confirmation Hearing Notice in the Solicitation Package.

13. The Debtors shall not be required to mail Solicitation Packages or other solicitation materials to Holders of Claims and Interests that have already been paid in full during the Chapter 11 Cases either through a critical vendor or cure payment (or as per the agreements of the parties) or that are authorized to be paid in full in the ordinary course of business pursuant to an order previously entered by this Court.

14. Any party that receives materials in electronic format, but would prefer to receive materials in paper format, may contact the Solicitation Agent and request paper copies of the corresponding materials received in electronic format (to be provided at the Debtors' expense as soon as practical following such request).

F. Approval of the Confirmation Hearing Notice

15. The Confirmation Hearing Notice, substantially in the form attached to this Order as **Exhibit 6**, is approved and shall be served by the Debtors on all known Holders of Claims and Interests as of the Voting Record Date and any other party entitled to notice under Bankruptcy Rule 2002 and applicable Bankruptcy Local Rules (regardless of whether such parties are entitled to vote on the Plan) by no later than the Solicitation Deadline. The Debtors shall also publish the Confirmation Hearing Notice or a notice substantially similar thereto (excluding the release, exculpation, and injunction provisions quoted therein) by the Solicitation Deadline in the national edition of *USA Today*.

16. The Confirmation Hearing Notice constitutes adequate and sufficient notice of the Plan, the Disclosure Statement, the Confirmation Hearing, the Confirmation Objection Deadline, and the release, injunction, and exculpation provisions contained in the Plan.

G. Approval of the Form of Non-Voting Status Notices

17. The Non-Voting Status Notices, substantially in the forms attached to this Order as **Exhibits 4A** and **4B** are approved. Except to the extent that the Debtors determine otherwise, the Debtors are not required to provide Solicitation Packages to (a) Holders of Claims or Interests in Non-Voting Classes and (b) Holders of Claims and Interests that are subject to a pending objection by the Debtors and who are not entitled to vote the disputed portion of such Claims or Interests. Instead, on or before the Solicitation Deadline, the Solicitation Agent shall serve an applicable Non-Voting Status Notice in lieu of Solicitation Packages to those Holders of Claims and Interests in the Non-Voting Classes, who are not entitled to vote on the Plan. The Debtors shall serve a Non-Voting Status Notice upon on any Holder of Claims or Interests with respect to which the Debtors file an objection on or before the Claim Solicitation Objection Deadline.

H. Approval of the Form of Assumption Notice

18. The Assumption Notice, substantially in the form attached to this Order as **Exhibit 5**, is approved. The Debtors shall serve, by no later than the Assumption Notice Service Deadline, the Assumption Notice upon the applicable counterparties to the executory contracts and unexpired leases that will be assumed pursuant to the Plan. The deadline for any counterparty to object to the assumption or proposed cure amounts set forth in the Assumption Notice shall be **30 calendar days following the date of service thereof at 11:59 p.m. (prevailing Central Time)** (the "Cure Objection Deadline"). If no objection to the cure amount or the proposed assumption and assignment of any executory contract or unexpired lease is filed by the Cure Objection Deadline, then such party will be deemed to have stipulated that the applicable cure amount as determined by the Debtors is correct, and such party will be forever barred, estopped, and enjoined from asserting any additional cure amount under the executory contract or unexpired lease proposed to be assumed or from objecting to the proposed assumption and assignment thereof;

provided, that the foregoing shall not relieve any such counterparty of its obligation to file a Proof of Claim to the extent that its executory contract or unexpired lease is rejected pursuant to the Plan.

I. Service of Solicitation Materials and Undeliverable Notices and Solicitation Materials

19. For purposes of serving the Solicitation Packages and Non-Voting Status Notices, the Debtors may rely on the address information for the creditors receiving such notices as compiled, updated, and maintained by the Solicitation Agent or the Debtors, as applicable, as of the Voting Record Date, without any requirement to conduct additional research for updated addresses based on undeliverable Solicitation Packages (including the Ballots) or Non-Voting Status Notices.

20. The Debtors may, but shall not be required to, (a) redistribute the Confirmation Hearing Notice, Solicitation Packages, and/or any other notices approved by this Order to any entity to the extent any such notices or materials sent to such entity's listed address are returned as undeliverable; or (b) send the Confirmation Hearing Notice, Solicitation Package, and/or any other notices approved by this Order to any address that the Debtors have sent a notice in the last two (2) months, which notice was returned as undeliverable. The failure to distribute materials and notices to such entities in accordance with the foregoing shall not constitute inadequate notice of the Confirmation Hearing Notice, the Solicitation Package, the Plan, the Disclosure Statement, or any deadlines approved by this Order, or a violation of the Bankruptcy Code or Bankruptcy Rules. The Solicitation Agent shall maintain a record of (i) all Confirmation Hearing Notices and Solicitation Packages that are returned as undeliverable and (ii) all addresses to which the Solicitation Agent did not send a Confirmation Hearing Notice or Solicitation Package in accordance with the foregoing on account of previously undeliverable notices. The Solicitation Agent shall provide a summary of such records to counsel to the Bondholder Committee one week after the Solicitation Deadline and updates to such summary each week thereafter.

K. Miscellaneous

21. In the event of any conflict between the provisions of this Order and the terms of the Solicitation Procedures attached hereto and approved hereby, the terms of the Solicitation Procedures shall govern.

22. The Debtors' rights to modify or withdraw the Plan and the Disclosure Statement in accordance with their terms, subject to the consent rights set forth in the Mediation Agreement, or with the approval of the Court, as applicable, are reserved.

23. The Debtors are authorized to make non-substantive and non-material changes to the Plan, Disclosure Statement, Confirmation Hearing Notice, Solicitation Procedures, Ballots, Non-Voting Status Notices, the Assumption Notice, and related documents without further order of the Court.

24. Nothing in this Order shall be construed as a waiver of the right of the Debtors or any other party in interest, as applicable, to object to a Proof of Claim after the Voting Record Date.

25. All time periods set forth in this Order shall be calculated in accordance with Bankruptcy Rule 9006(a).

26. The Debtors are authorized to take all actions necessary to effectuate the relief granted in this Order.

27. Notwithstanding any Bankruptcy Rule to the contrary, this Order shall be immediately effective upon its entry.

28. This Court retains exclusive jurisdiction with respect to all matters arising from or related to the implementation, interpretation, and enforcement of this Order.

Signed: April 21, 2023



Marvin Isgur
United States Bankruptcy Judge

Exhibit 1

Disclosure Statement

Exhibit 2

Chapter 11 Plan

IN THE UNITED STATES BANKRUPTCY COURT
FOR THE SOUTHERN DISTRICT OF TEXAS
HOUSTON DIVISION

In re:)
) Chapter 11
)
GWG Holdings, Inc., et al.,1)
) Case No. 22-90032 (MI)
)
Debtors.)
) (Jointly Administered)
)

DEBTORS' FURTHER MODIFIED SECOND AMENDED JOINT CHAPTER 11 PLAN,
SUBMITTED BY THE DEBTORS, THE BONDHOLDER COMMITTEE,
AND L BOND MANAGEMENT, LLC AS CO-PROONENTS

April 20, 2023

JACKSON WALKER LLP

Kristhy M. Peguero (TX Bar No. 24102776)
Matthew D. Cavenaugh (TX Bar No. 24062656)
1401 McKinney Street, Suite 1900
Houston, TX 77010
Telephone: (713) 752-4200
Email: kpeguero@jw.com
mcavenaugh@jw.com

Co-Counsel for the Debtors and Debtors in Possession

MAYER BROWN LLP

Charles S. Kelley (TX Bar No. 11199580)
700 Louisiana Street, Suite 3400
Houston, TX 77002-2730
Telephone: (713) 238-3000
Email: ckelley@mayerbrown.com

Thomas S. Kiriakos (admitted pro hac vice)
Louis S. Chiappetta (admitted pro hac vice)
Jamie R. Netznik (admitted pro hac vice)

Lisa Holl Chang
Joshua R. Gross (admitted pro hac vice)
Jade Edwards
71 S. Wacker Drive
Chicago, IL 60606
Telephone: (312) 782-0600
Email: tkiriakos@mayerbrown.com
lchiappetta@mayerbrown.com
jnetznik@mayerbrown.com
lhollchang@mayerbrown.com
jgross@mayerbrown.com
jmedwards@mayerbrown.com

Adam C. Paul (admitted pro hac vice)
Lucy F. Kweskin (admitted pro hac vice)
Ashley Anglade
1221 Avenue of the Americas
New York, NY 10020-1001
Telephone: (212) 506-2500
Email: apaul@mayerbrown.com
lkweskin@mayerbrown.com
aanglade@mayerbrown.com

Counsel for the Debtors and Debtors in Possession

1 The Debtors in these chapter 11 cases, along with the last four digits of each Debtor's federal tax identification number, are: GWG Holdings, Inc. (2607); GWG Life, LLC (6955); GWG Life USA, LLC (5538); GWG DLP Funding IV, LLC (2589); GWG DLP Funding VI, LLC (6955); and GWG DLP Funding Holdings VI, LLC (6955). The location of Debtor GWG Holdings, Inc.'s principal place of business and the Debtors' service address is 325 N. St. Paul Street, Suite 2650 Dallas, TX 75201. Further information regarding the Debtors and these chapter 11 cases is available at the website of the Debtors' claims and noticing agent: https://donlinrecano.com/gwg.

TABLE OF CONTENTS

	Page
ARTICLE I. DEFINED TERMS, RULES OF INTERPRETATION, COMPUTATION OF TIME, AND GOVERNING LAW	1
A. <i>Defined Terms.</i>	1
B. <i>Rules of Interpretation.</i>	22
C. <i>Computation of Time.</i>	22
D. <i>Governing Law.</i>	22
E. <i>Reference to Monetary Figures.</i>	23
F. <i>Controlling Document.</i>	23
G. <i>Proponents' Consent Right.</i>	23
 ARTICLE II. ADMINISTRATIVE CLAIMS, ACCRUED PROFESSIONAL FEE COMPENSATION CLAIMS, DIP CLAIMS, PRIORITY TAX CLAIMS, INDENTURE DIMINUTION CLAIMS, AND SUBSTANTIAL CONTRIBUTION CLAIMS	 24
A. <i>Administrative Claims.</i>	24
B. <i>Accrued Professional Compensation Claims.</i>	25
C. <i>Chapford DIP Facility Claims.</i>	27
D. <i>Vida DIP Claims.</i>	27
E. <i>DLP Secured Claims.</i>	27
F. <i>Indenture Diminution Claims.</i>	27
G. <i>Priority Tax Claims.</i>	27
H. <i>Allowed AHC Substantial Contribution Claim.</i>	28
I. <i>Substantial Contribution Compensation and Expenses.</i>	28
 ARTICLE III. CLASSIFICATION AND TREATMENT OF CLAIMS AND INTERESTS.....	 28
A. <i>Summary of Classification.</i>	28
B. <i>Treatment of Claims and Interests.</i>	29
C. <i>Special Provision Governing Unimpaired Claims.</i>	33
D. <i>Elimination of Vacant Classes.</i>	33
E. <i>Voting Classes; Presumed Acceptance by Non-Voting Classes.</i>	34
F. <i>Subordinated Claims.</i>	34
G. <i>Presumed Acceptance of Plan.</i>	34
H. <i>Presumed Rejection of Plan.</i>	34
I. <i>Acceptance by Impaired Classes of Claims.</i>	34
J. <i>Acceptance by Impaired Classes of Interests.</i>	34
K. <i>Confirmation Pursuant to Sections 1129(a)(10) and 1129(b) of the Bankruptcy Code.</i>	35
L. <i>Controversies Regarding Impairment.</i>	35
 ARTICLE IV. MEANS FOR IMPLEMENTATION OF THE PLAN	 35
A. <i>Wind Down Trust.</i>	35
B. <i>U.S. Federal Income Tax Treatment and Reporting.</i>	38
C. <i>General Settlement of Claims and Interests.</i>	40
D. <i>Wind Down Transactions.</i>	40
E. <i>Litigation Trust.</i>	41
F. <i>Sources of Plan Consideration.</i>	44
G. <i>Redemption of New WDT Interests.</i>	46
H. <i>Priority of Cash Distributions to Holders of New WDT Interests.</i>	47
I. <i>LBM Settlement.</i>	48
J. <i>Exemption from Registration Requirements.</i>	49
K. <i>Section 1146(a) Exemption.</i>	50
L. <i>Cancellation of Securities and Agreements.</i>	51
M. <i>Corporate Action.</i>	51

N.	<i>Dissolution and Board of Directors.</i>	52
O.	<i>Effectuating Documents; Further Transactions.</i>	53
P.	<i>Vesting of Assets.</i>	53
Q.	<i>Preservation of Causes of Action.</i>	53
R.	<i>Continuing Effectiveness of Final Orders.</i>	54
S.	<i>D&O Liability Insurance Policies.</i>	55
T.	<i>Payment of Certain Fees.</i>	55
U.	<i>Beneficient SPAC Transaction Consents.</i>	56
V.	<i>Termination of Any Continuing Business Relationship With Beneficient.</i>	56
W.	<i>Compensation for Messrs. Stein and Horton.</i>	57
ARTICLE V. TREATMENT OF EXECUTORY CONTRACTS AND UNEXPIRED LEASES		57
A.	<i>Assumption and Rejection of Executory Contracts and Unexpired Leases.</i>	57
B.	<i>Claims Based on Rejection of Executory Contracts or Unexpired Leases.</i>	58
C.	<i>Cure of Defaults for Assumed Executory Contracts and Unexpired Leases.</i>	58
D.	<i>Insurance Policies.</i>	59
E.	<i>Modifications, Amendments, Supplements, Restatements, or Other Agreements.</i>	59
F.	<i>Reservation of Rights.</i>	60
G.	<i>Non-occurrence of the Effective Date.</i>	60
ARTICLE VI. PROVISIONS GOVERNING DISTRIBUTIONS		60
A.	<i>Timing and Calculation of Amounts to Be Distributed.</i>	60
B.	<i>Distributing Parties.</i>	60
C.	<i>Delivery of Distributions Related to the Litigation Trust.</i>	61
D.	<i>Delivery of Distributions and Undeliverable or Unclaimed Distributions.</i>	62
E.	<i>Single Satisfaction of Claims and Interests.</i>	64
F.	<i>No Postpetition Interest On Claims.</i>	64
G.	<i>Compliance with Tax Requirements/Allocations.</i>	64
H.	<i>Setoffs.</i>	64
I.	<i>Allocation of Plan Distributions between Principal and Interest.</i>	65
J.	<i>Claims Paid or Payable by Third Parties.</i>	65
ARTICLE VII. PROCEDURES FOR RESOLVING CONTINGENT, UNLIQUIDATED, AND DISPUTED CLAIMS		66
A.	<i>Allowance of Claims.</i>	66
B.	<i>Claims Administration Responsibilities.</i>	66
C.	<i>Estimation of Claims.</i>	67
D.	<i>Adjustment to Claims or Interests without Objection.</i>	67
E.	<i>Disallowance of Claims and Interests.</i>	67
F.	<i>Disputed Claims Reserve.</i>	68
G.	<i>Amendments to Claims.</i>	69
H.	<i>No Distributions Pending Allowance.</i>	69
I.	<i>Distributions After Allowance.</i>	69
ARTICLE VIII. SETTLEMENT, RELEASE, INJUNCTION, AND RELATED PROVISIONS		69
A.	<i>Settlement, Compromise, and Release of Claims and Interests.</i>	69
B.	<i>Release of Liens.</i>	70
C.	<i>Releases by the Debtors.</i>	70
D.	<i>[RESERVED.]</i>	72
E.	<i>Exculpation.</i>	72
F.	<i>Protections Against Discriminatory Treatment after the Effective Date.</i>	73
G.	<i>Injunction.</i>	73
H.	<i>Recoupment.</i>	74
I.	<i>Subordination Rights.</i>	74
J.	<i>Ipsa Facto and Similar Provisions Ineffective.</i>	74
K.	<i>Reimbursement or Contribution.</i>	74

ARTICLE IX. CONDITIONS PRECEDENT TO CONFIRMATION AND THE EFFECTIVE DATE.....75

A. *Conditions Precedent to the Effective Date.*75

B. *Effect of Non-Occurrence of Conditions Precedent to Consummation.*.....77

C. *Waiver of Conditions Precedent.*77

ARTICLE X. MODIFICATION, REVOCATION, OR WITHDRAWAL OF THE PLAN.....77

A. *Modification and Amendments.*.....77

B. *Effect of Confirmation on Modifications.*.....77

C. *Revocation or Withdrawal of the Plan.*78

ARTICLE XI. RETENTION OF JURISDICTION78

ARTICLE XII. MISCELLANEOUS PROVISIONS80

A. *Immediate Binding Effect.*80

B. *Additional Documents.*81

C. *Payment of Statutory Fees.*81

D. *Dissolution of the Bondholder Committee.*81

E. *Reservation of Rights.*81

F. *Successors and Assigns.*82

G. *Service of Documents.*.....82

H. *Enforcement of Confirmation Order.*83

I. *Term of Injunctions or Stays.*83

J. *Entire Agreement.*83

K. *Votes Solicited in Good Faith.*83

L. *Exhibits.*84

M. *Nonseverability of Plan Provisions.*.....84

N. *Closing of Chapter 11 Cases.*.....84

O. *Creditor Default.*84

P. *Waiver or Estoppel.*.....84

INTRODUCTION

GWG Holdings, Inc. and its affiliated debtors and debtors in possession in the above-captioned chapter 11 cases propose the following joint plan pursuant to chapter 11 of title 11 of the United States Code. Capitalized terms used herein and not otherwise defined shall have the meanings ascribed to such terms in Article I.A hereof. Although proposed jointly for administrative purposes, this Plan constitutes a separate plan for each of the Debtors (as that term is defined herein) for the resolution of outstanding Claims and Interests pursuant to the Bankruptcy Code, and this Plan does not contemplate substantive consolidation of any of the Debtors. Each of the Debtors, the Bondholder Committee, and LBM is a proponent of this Plan within the meaning of section 1129 of the Bankruptcy Code.

The Plan is supported by the Bondholder Committee and LBM. The Plan, if consummated, will effectuate the terms of the Mediated Settlement (as reflected in the Mediation Agreement), which is further described in the Disclosure Statement.

Reference is made to the accompanying *Disclosure Statement for the Debtors' Further Modified Second Amended Joint Chapter 11 Plan* for a discussion of the Debtors' history, business, operations, valuation, projections, risk factors, a summary and analysis of this Plan and the transactions contemplated thereby, and certain related matters.

ALL HOLDERS OF CLAIMS AND INTERESTS, TO THE EXTENT APPLICABLE, ARE ENCOURAGED TO READ THIS PLAN AND THE DISCLOSURE STATEMENT IN THEIR ENTIRETY BEFORE VOTING TO ACCEPT OR REJECT THIS PLAN.

ARTICLE I. DEFINED TERMS, RULES OF INTERPRETATION, COMPUTATION OF TIME, AND GOVERNING LAW

A. *Defined Terms.*

As used in this Plan, capitalized terms have the meanings and effect as set forth below.

1. “1940 Act” means the U.S. Investment Company Act of 1940, as amended, 15 U.S.C. §§ 80a-1–80a-64, or any similar federal, state, or local law, as now in effect or hereafter amended, and the rules and regulations promulgated thereunder.

2. “2018 Supplemental Indenture” means that certain Supplemental Indenture, dated as of August 10, 2018, as amended, restated, amended and restated, supplemented, or otherwise modified from time to time, among Debtors GWGH and GWG Life and the Indenture Trustee, to add and modify certain provisions of the A&R Indenture necessary to provide for the issuance of the Seller Trust L Bonds.

3. “2020 Supplemental Indenture” means that certain Supplemental Indenture, dated as of December 31, 2020, as amended, restated, amended and restated, supplemented, or otherwise modified from time to time, among Debtors GWGH and GWG Life and the Indenture Trustee, to add and modify certain provisions of the A&R Indenture necessary to provide for the issuance of the Liquidity Bonds.

4. “A&R Indenture” means that certain Amended and Restated Indenture, dated as of October 23, 2017, as amended, restated, amended and restated, supplemented, or otherwise modified from time to time, among Debtors GWGH and GWG Life and the Indenture Trustee, providing for the issuance of the Public L Bonds, the Seller Trust L Bonds, and the Liquidity Bonds.

5. “Accrued Professional Compensation Claims” means, at any given moment, all Claims for accrued fees and expenses for services rendered by a Professional through and including the Confirmation Date, to the extent such fees and expenses have not been paid pursuant to the Interim Compensation Order or any other order of the Bankruptcy Court and regardless of whether a fee application has been Filed for such fees and expenses; *provided* that, to the extent the Bankruptcy Court denies or reduces by a Final Order any amount of a Professional’s requested fees or expenses, then the amount by which such fees or expenses are reduced or denied shall reduce the applicable Accrued Professional Compensation Claim and the Professional Fee Escrow Amount with respect to such Claim.

6. “Ad Hoc Broker/Dealer Committee” means an ad hoc committee of registered broker/dealers and registered investment advisors, which committee is represented by Proskauer Rose LLP.

7. “Administrative Claim” means a Claim for costs and expenses of the administration of the Estates pursuant to sections 503(b), 507(a)(2), 507(b), or 1114(e)(2) of the Bankruptcy Code, including: (a) the actual and necessary costs and expenses of preserving the Estates and operating the business of the Debtors incurred after the applicable Petition Date and through the Effective Date; (b) Accrued Professional Compensation Claims; (c) the Independent Director Fee Claims; (d) fees and charges assessed against the Estates pursuant to chapter 123 of the Judicial Code, including the fees of the U.S. Trustee payable pursuant to section 1930(a) of the Judicial Code; (e) the Indenture Diminution Claims; and (f) the Allowed AHC Substantial Contribution Claim.

8. “Administrative Claims Payment Date” means, with respect to an Administrative Claim, the earlier of: (a) the Effective Date; (b) if the Administrative Claim is not Allowed as of the Effective Date, as soon as reasonably practicable after the date on which an order Allowing such Administrative Claim becomes a Final Order; and (c) if the Allowed Administrative Claim is based on liabilities incurred by the Debtors in the ordinary course of their business after the applicable Petition Date, pursuant to the terms and conditions of the particular transaction giving rise to such Allowed Administrative Claims, without any further action by the Holders of such Allowed Administrative Claims and without any further notice to or action, order, or approval of the Bankruptcy Court.

9. “Affiliate” has the meaning set forth in section 101(2) of the Bankruptcy Code.

10. “Allowed” means with reference to any Claim or Interest, as applicable: (a) any Claim (i) for which a Proof of Claim or Proof of Interest has been timely Filed on or before the applicable Claims Bar Date (or for which a Proof of Claim or Proof of Interest is not required to be Filed pursuant to the Bankruptcy Code or a Final Order), or (ii) that is identified in the Schedules as of the Effective Date as not disputed, not contingent, and not unliquidated, and for which no

Proof of Claim or Proof of Interest has been timely Filed; *provided*, that, in each case, any such Claim shall be considered Allowed only if and to the extent that no objection or other challenge to the allowance thereof has been timely Filed prior to the Claim Objection Bar Date or such objection or challenge has been timely Filed and the Claim thereafter has been Allowed by a Final Order; or (b) any Claim expressly deemed allowed by the Plan (except as addressed in Article IV.I hereof) or allowed by a Final Order of the Bankruptcy Court (including pursuant to any stipulation or settlement agreement approved by the Bankruptcy Court). Claims allowed solely for the purpose of voting to accept or reject the Plan pursuant to an order of the Bankruptcy Court shall not be considered Allowed Claims unless otherwise subsequently Allowed. Any Claim that has been or is hereafter listed in the Schedules as contingent, unliquidated, or disputed, and for which no contrary or superseding Proof of Claim is or has been timely Filed, or that is not or has not been Allowed by a Final Order, is not considered Allowed and shall be expunged without further action by the Debtors and without further notice to any party or action, approval, or order of the Bankruptcy Court. Notwithstanding anything to the contrary herein, no Claim of any Entity subject to section 502(d) of the Bankruptcy Code shall be deemed Allowed unless and until such Entity pays in full the amount that it owes the applicable Debtor or Wind Down Debtor, as applicable. For the avoidance of doubt, a Proof of Claim Filed after the applicable Claims Bar Date shall not be Allowed for any purposes whatsoever absent entry of a Final Order Allowing such late-Filed Claim. “Allow” and “Allowing” shall have correlative meanings.

11. “Allowed AHC Substantial Contribution Claim” means the Administrative Claim of the Ad Hoc Broker/Dealer Committee, which shall be Allowed upon entry of the Confirmation Order, for the actual and reasonable fees and expenses of the Ad Hoc Broker/Dealer Committee which shall be payable on the Effective Date as set forth in Article II.H hereof.

12. “Allowed Bondholder Claims” means: (a) with respect to Direct-Held Bonds (as defined in the Bondholder Claim Procedures Order), (i) to the extent a timely Bondholder POC Form has been Filed pursuant to the Bondholder Claim Procedures Order, Bondholder Claims shall be Allowed in the amount set forth in any such Bondholder POC Form, provided, that, in each case, any such Bondholder Claim shall be considered Allowed only if and to the extent that no objection or other challenge to the allowance thereof has been timely Filed prior to the Claim Objection Bar Date or such an objection or other challenge has been Filed and the Bondholder Claim thereafter has been Allowed by a Final Order, or (ii) to the extent that no Bondholder POC Form has been timely Filed, Bondholder Claims shall be Allowed in the amounts set forth in the Holder Notices pursuant to the Bondholder Claim Procedures Order; (b) with respect to Indirect-Held Bonds (as defined in the Bondholder Claim Procedures Order), Bondholder Claims Allowed pursuant to the Bondholder Claim Procedures Order; and (c) the LBM L Bond Claims otherwise Allowed to the extent provided by Article IV.I hereof (which, for the avoidance of doubt, do not include the LBM Subordinated Claims).

13. “Assets” means all of the Debtors’ property, rights, and interests that are property of the Estates pursuant to section 541 of the Bankruptcy Code.

14. “Avoidance Actions” means any and all actual or potential claims and causes of action to avoid, recover, or subordinate a transfer of property or an obligation incurred by the Debtors that may be brought by or on behalf of the Debtors or their Estates pursuant to any applicable section of the Bankruptcy Code, including sections 502, 510, 542, 544, 545, 547-553,

and 724(a) of the Bankruptcy Code or under similar or related state, federal, or foreign statutes and common law, including fraudulent transfer laws or other applicable law.

15. “Bankruptcy Code” means title 11 of the United States Code, 11 U.S.C. §§ 101-1532, as amended.

16. “Bankruptcy Court” means the United States Bankruptcy Court for the Southern District of Texas, Houston Division, having jurisdiction over the Chapter 11 Cases and, to the extent of the withdrawal of any reference under 28 U.S.C. § 157, pursuant to section 151 of the Judicial Code, the United States District Court for the Southern District of Texas.

17. “Bankruptcy Local Rules” means the Bankruptcy Local Rules for the Southern District of Texas.

18. “Bankruptcy Rules” means the Federal Rules of Bankruptcy Procedure promulgated under section 2075 of the Judicial Code and the chambers rules of the Bankruptcy Court.

19. “Beneficient” means The Beneficient Company Group, L.P. and its subsidiaries.

20. “Bond Claims” means, collectively: (a) the Allowed Bondholder Claims; (b) any Indenture Fee and Expense Claims; and (c) subject to Article IV.I hereof, the LBM Subordinated Claims.

21. “Bondholder Claims” means any Claims for principal or interest evidenced by, arising under, or in connection with the Indenture (other than the LBM Subordinated Claims).

22. “Bondholder POC Forms” shall have the meaning set forth in the Bondholder Claim Procedures Order.

23. “Bondholder Claim Procedures Order” means the order entered by the Bankruptcy Court on August 29, 2022 [Dkt. No. 739].

24. “Bondholder Committee” means the official committee of bondholders appointed by the U.S. Trustee in the Chapter 11 Cases on May 9, 2022 [Dkt. No. 214].

25. “Broker Dealer(s)” means the registered broker/dealers and registered investment advisers that the Public L Bonds were offered and sold through.

26. “Business Day” means any day, other than a Saturday, Sunday, or “legal holiday” (as defined in Bankruptcy Rule 9006(a)).

27. “Cash” means the legal tender of the United States or the equivalent thereof.

28. “Causes of Action” means any claim, cause of action (including Avoidance Actions), controversy, right of setoff, cross-claim, counterclaim, or recoupment and any claim on contracts or for breaches of duties imposed by law or in equity, demand, right, action, Lien, indemnity, guaranty, suit, obligation, liability, damage, judgment, account, defense, power,

privilege, license, and franchise of any kind or character whatsoever, known, unknown, fixed or contingent, matured or unmatured, suspected or unsuspected, liquidated or unliquidated, disputed or undisputed, Secured or unsecured, assertable directly or derivatively, whether arising before, on, or after the applicable Petition Date, in contract or in tort, in law or in equity, or pursuant to any other theory of law.

29. “Certificate” means any instrument evidencing a Claim or Interest.

30. “Chapford DIP Facility” means the “Final DIP Facility,” as defined in the Chapford Final DIP Order.

31. “Chapford DIP Facility Claims” means any and all Claims for principal, interest, fees, costs, expenses, disbursements, and any and all other obligations of any kind under the Chapford DIP Facility, including any “DIP Obligations” (as defined in the Chapford Final DIP Order) owing as of the Effective Date; provided that, for the avoidance of doubt, the Chapford DIP Facility Claims shall not include the purported Alternate Stalking Horse Fee (as defined in the Chapford Final DIP Order).

32. “Chapford Final DIP Order” means the *Final Order (I) Authorizing the Debtors to Obtain Postpetition Financing, (II) Authorizing the Debtors to Use Cash Collateral, (III) Granting Liens and Providing Claims* [Dkt. No. 606].

33. “Chapter 11 Cases” means the jointly-administered chapter 11 cases of the Debtors pending before the Bankruptcy Court under the lead case of GWG Holdings, Inc., *et al.*, No. 22-90032 (MI) (Bankr. S.D. Tex.).

34. “Claim” means any “claim” (as defined in section 101(5) of the Bankruptcy Code).

35. “Claims Bar Date” means the applicable bar date by which a Proof of Claim or Proof of Interest, or request for payment of administrative expenses must be, or must have been, Filed, as established by an order of the Bankruptcy Court, including the Confirmation Order.

36. “Claims Objection Bar Date” shall mean, subject to rule 9006 of the Federal Rules of Bankruptcy Procedure, the date that is 180 days following the Effective Date.

37. “Claims Register” means the official register of Claims maintained by the Clerk of the Bankruptcy Court or the Notice and Solicitation Agent.

38. “Class” means a category of Holders of Claims or Interests as set forth in Article III of the Plan in accordance with section 1122(a) of the Bankruptcy Code.

39. “Compensation Motion” means the *Debtors’ Motion for Entry of an Order Approving Amendments to Consulting Agreement With Jeffrey S. Stein and Independent Director Agreement With Anthony R. Horton and Granting Related Relief* [Dkt. No. 1392].

40. “Confirmation” means the entry of a Confirmation Order on the docket of the Chapter 11 Cases.

41. “Confirmation Date” means the date upon which the Bankruptcy Court enters the Confirmation Order on the docket of the Chapter 11 Cases within the meaning of Bankruptcy Rules 5003 and 9021.

42. “Confirmation Hearing” means the hearing held by the Bankruptcy Court to consider entry of a Confirmation Order pursuant to section 1129 of the Bankruptcy Code.

43. “Confirmation Order” means a Final Order of the Bankruptcy Court confirming the Plan pursuant to section 1129 of the Bankruptcy Code, the form and substance of which being subject to the Proponents’ Consent Right.

44. “Consummation” means the occurrence of the Effective Date for the Plan.

45. “Creditor Proponents” means the Bondholder Committee and LBM.

46. “CRO/ID Order” means the *Order Authorizing and Approving (I) Designation of Jeffrey S. Stein as Chief Restructuring Officer, (II) the Appointment of Jeffrey S. Stein and Anthony R. Horton as New Independent Directors, and (III) Granting Related Relief* [Dkt. No. 594].

47. “Cure Amounts” means all amounts (or such other amount as may be agreed upon by the parties under an Executory Contract or Unexpired Lease) required to cure any monetary defaults and other obligations required to cure any non-monetary defaults (the performance required to cure such non-monetary defaults and the timing of such performance will be described in reasonable detail in a notice of proposed assumption and assignment) under any Executory Contract or Unexpired Lease that is to be assumed or assumed and assigned by the Debtors pursuant to sections 365 or 1123 of the Bankruptcy Code.

48. “D&O Insurance Order” has the meaning set forth in Article II.B.1 hereof.

49. “D&O Liability Insurance Policies” means all insurance policies (including, without limitation, directors and officers liability policy, management liability policy, professional liability policy, general liability policy, errors and omissions policy, excess policy, umbrella policy, and/or any “tail policy”) for current or former directors, members, trustees, officers, and managers’ liability maintained by the Debtors as of the Effective Date.

50. “Debtors” means, collectively, GWG Holdings, Inc., GWG Life, LLC, GWG Life USA, LLC, GWG DLP Funding IV, LLC, GWG DLP Funding VI, LLC, and GWG DLP Funding Holdings VI, LLC.

51. “Debtor Release” means the releases set forth in Article VIII.C of this Plan.

52. “Direct Holder Notices” shall have the meaning set forth in the Bondholder Claim Procedures Order.

53. “Disclosure Statement” means the disclosure statement (including all exhibits and schedules thereto or referenced therein), as may be amended, supplemented, or modified from time to time, that relates to this Plan and has been prepared and distributed by the Debtors, the

Bondholder Committee, and LBM as joint plan proponents in accordance with the Bankruptcy Code, the Bankruptcy Rules, and any other applicable law.

54. “Disputed” means, with respect to any Claim or Interest or any portion thereof: (a) any Claim or Interest that is not Allowed; (b) any Claim or Interest that is not disallowed under the Plan, the Bankruptcy Code, or a Final Order, as applicable; and (c) any Claim or Interest to which any party in interest has interposed a timely objection or request for estimation, and such objection or request for estimation has not been withdrawn or determined by a Final Order. For the avoidance of doubt, a Disputed Claim or Interest shall not include any Claim or Interest that has been deemed Allowed under the Plan (except as otherwise addressed in Article IV.I hereof) or by Final Order.

55. “Disputed Claims Reserve” means a reserve in an amount equal to the Disputed Claims Reserve Amount for distributions on account of Disputed Claims that are subsequently Allowed after the Effective Date. To the extent that any Claim is Disputed, and where this Plan provides for the payment in Cash on the Effective Date of such Claim if such Claim were Allowed, on the Effective Date, the Debtors shall transfer the pro rata portion of such Claim’s distribution under the Plan to the Disputed Claims Reserve, where such amount shall be held in trust for the benefit of such Holder pending resolution by a Final Order or as otherwise agreed between the Wind Down Debtors on one hand, and such Holder on the other hand. The Wind Down Trust shall have a reversionary interest, which shall be distributed in accordance with Article III and Article IV.H of this Plan, in the excess, if any, of any Cash or other property held in the Disputed Claims Reserve on account of any Disputed Claim after such Disputed Claim or portion thereof ultimately is disallowed by a Final Order or otherwise resolved between the Holder of the Disputed Claim and the Wind Down Debtors in a manner that leaves an excess amount in the Disputed Claims Reserve.

56. “Disputed Claims Reserve Amount” means the amount of assets determined prior to the Effective Date by the Debtors, in consultation with the Creditor Proponents, that would likely have been distributed to the Holders of all applicable Disputed Claims against the Debtors as if such Disputed Claims against the Debtors had been Allowed Claims against the Debtors on the Effective Date, with the amount of such Allowed Claims to be determined, solely for the purposes of establishing reserves and for maximum distribution purposes, to be: (a) the lesser of (i) the asserted amount of each Disputed Claim against the Debtors as scheduled by the Debtors or, if and solely to the extent a non-duplicative Proof of Claim was Filed in an asserted amount greater than the scheduled amount, the asserted amount Filed with the Bankruptcy Court as set forth in such non-duplicative Proof of Claim or as provided by the parties to the Debtors as further information with respect to the Proof of Claim, and (ii) the amount, if any, estimated by the Bankruptcy Court pursuant to section 502(c) of the Bankruptcy Code or ordered by other order of the Bankruptcy Court; or (b) the amount otherwise agreed to by the Debtors and the Holder of such Disputed or unliquidated Claim for reserve purposes.

57. “Distribution Record Date” means, other than with respect to publicly-held securities, the record date for purposes of making distributions under the Plan on account of Allowed Claims and Allowed Interests, which date shall be the later of the first day of the Confirmation Hearing or the day that such Claim becomes an Allowed Claim.

58. “DLP Entities” means Debtors DLP IV, DLP VI, and GWG DLP Funding Holdings VI, LLC.

59. “DLP Entity General Unsecured Claims” mean any Claim against any of the DLP Entities that is not Secured and that is not: (a) an Administrative Claim; (b) Chapford DIP Facility Claim; (c) Vida DIP Claim; (d) DLP Secured Claim; (e) Priority Tax Claim; (f) Other Secured Claim; (g) Other Priority Claim; (h) Bond Claim; or (i) Intercompany Claim.

60. “DLP Independent Directors” means Albert J. Fioravanti and Sean Clements.

61. “DLP IV” means Debtor GWG DLP Funding IV, LLC.

62. “DLP IV Agent” means CLMG Corp., in its capacity as the administrative agent under the DLP IV Credit Agreement.

63. “DLP IV Credit Agreement” means that certain Fifth Amended and Restated Loan and Security Agreement (as may be amended, restated, amended and restated, supplemented, or otherwise modified from time to time), dated December 14, 2021, by and between Debtor DLP IV as borrower, DLP IV Agent as administrative agent, and the DLP IV Lenders as lenders thereto.

64. “DLP IV Lenders” means the lenders from time to time party to the DLP IV Credit Agreement.

65. “DLP IV Secured Claims” means any Claims evidenced by, arising under, or in connection with the DLP IV Credit Agreement or other agreements related thereto.

66. “DLP Secured Claims” means, collectively, the DLP IV Secured Claims and the DLP VI Secured Claims.

67. “DLP VI” means Debtor GWG DLP Funding VI, LLC.

68. “DLP VI Agent” means National Founders LP, in its capacity as the administrative agent under the DLP VI Credit Agreement.

69. “DLP VI Credit Agreement” means that certain Credit Agreement (as may be amended, restated, amended and restated, supplemented, or otherwise modified from time to time), dated August 11, 2021, by and among the Debtor DLP VI as borrower, DLP VI Agent as administrative agent, and DLP VI Lender as the sole lender.

70. “DLP VI Lender” means National Founders LP, in its capacity as the sole lender under the DLP VI Credit Agreement.

71. “DLP VI Secured Claims” means any Claims evidenced by, arising under, or in connection with the DLP VI Credit Agreement or other agreements related thereto.

72. “DTC” means The Depository Trust Company.

73. “Effective Date” means, with respect to the Plan, the date that is a Business Day selected by the Debtors, in consultation with the Creditor Proponents, on or after the Confirmation Date on which: (a) no stay of the Confirmation Order is in effect; (b) all conditions precedent specified in Article IX.A of this Plan have been satisfied or waived (in accordance with Article IX.C of this Plan); and (c) the Debtors declare that the Plan is effective.

74. “Entity” shall have the meaning set forth in section 101(15) of the Bankruptcy Code.

75. “Estate” means, as to each Debtor, the estate created for the Debtor pursuant to section 541 of the Bankruptcy Code upon the commencement of the applicable Debtor’s Chapter 11 Case.

76. “Estimated Effective Date Shortfall Amount” means the amount, if any, that the Debtors, in consultation with the Creditor Proponents, estimate prior to the Effective Date to be the difference between: (a) all Allowed Claims required to be paid or provided for in full, in Cash on the Effective Date under the provisions of this Plan; and (b) the amount of Cash that the Debtors expect to have available for such purpose on the Effective Date that does not consist of any of the net Cash proceeds of the Vida DIP Financing Facility.

77. “Exculpated Claim” means any claim related to any act or omission from the Petition Date to the Effective Date in connection with, relating to, or arising out of: (a) the Chapter 11 Cases; (b) the formulation, preparation, dissemination, or negotiation of any document in connection with the Chapter 11 Cases; (c) any contract, instrument, release, and/or other agreement or document created or entered into in connection with the Chapter 11 Cases; (d) the pursuit of Consummation; and/or (e) the Filing, administration, and/or implementation of the Chapter 11 Cases, or the distribution of property in connection therewith or thereunder; *provided*, that, for the avoidance of doubt, any prepetition advice provided by any legal professionals in connection with prepetition transactions between the Debtors and Beneficiary shall not constitute any act or omission that is covered by this definition of Exculpated Claim; *provided, further*, that, notwithstanding the foregoing, Exculpated Claims shall not include anything related to any act or omission that is determined in a Final Order to have constituted actual fraud, willful misconduct, intentional breach of fiduciary duty, or gross negligence.

78. “Exculpated Party” means, collectively, and in each case, in their respective capacities as such: (a) Jeffrey S. Stein, in his capacities as an officer, an Independent Director, and a director of the Debtors; (b) Anthony R. Horton, in his capacities as an Independent Director and director of the Debtors; (c) Michael A. Tucker, in his capacity as an officer of the Debtors; (d) the Non-Management Directors, in their capacity as such; (e) the DLP Independent Directors, in their capacity as such; (f) the members of the Bondholder Committee, in their capacity as such; (g) any Professional retained by the Debtors, the Independent Directors, the DLP Independent Directors, the Bondholder Committee, in such Professionals’ capacity as such; and (h) any professional retained by any of the members of the Bondholder Committee, each in such professionals’ capacity as such.

79. “Executory Contract” means a contract to which a Debtor is a party that is subject to assumption, assumption and assignment, or rejection under sections 365 or 1123 of the Bankruptcy Code.

80. “Existing Common Interests” means the Interests in Debtor GWGH arising from or related to the Existing Common Stock.

81. “Existing Common Stock” means the shares of common stock issued by Debtor GWGH.

82. “Federal Judgment Rate” means the federal judgment rate in effect as of the Effective Date.

83. “File,” “Filed,” or “Filing” means file, filed, or filing in the Chapter 11 Cases with the Bankruptcy Court or, with respect to the filing of a Proof of Claim or Proof of Interest, the Notice and Solicitation Agent.

84. “Final Vida Order” means the *Final Order (A) Authorizing the Debtors to Obtain Replacement DIP Financing From Vida Insurance Credit Opportunity Fund III GP, LLC and Its Affiliates and Enter Into and Perform Under the Replacement DIP Credit Documents, (B) Authorizing the Debtors to Use Cash Collateral, (C) Granting Liens and Providing Claims with Superpriority Administrative Expense Status, (D) Authorizing the Refinancing of Prepetition and Postpetition Secured Debt, (E) Authorizing Amending the Option Agreement, (F) Modifying the Automatic Stay, and (G) Granting Related Relief* [Dkt. No. 1144].

85. “Final Order” means, as applicable, an order or judgment of the Bankruptcy Court or other court of competent means, as applicable, an order or judgment of the Bankruptcy Court or other court of competent jurisdiction with respect to the relevant subject matter, which has not been reversed, stayed, modified, or amended, and as to which the time to appeal or seek certiorari has expired and no appeal or petition for certiorari has been timely taken, or as to which any appeal that has been taken or any petition for certiorari that has been or may be Filed has been resolved by the highest court to which the order or judgment was appealed or from which certiorari was sought or the new trial, reargument, or rehearing shall have been denied, resulted in no stay pending appeal of such order, or has otherwise been dismissed with prejudice; *provided* that the possibility that a motion under rule 60 of the Federal Rules of Civil Procedure, or any analogous rule under the Bankruptcy Rules or the Bankruptcy Local Rules, may be Filed relating to such order shall not prevent such order from being a Final Order.

86. “FOXO” means FOXO Technologies, Inc.

87. “General Unsecured Claim” means any Claim that is not Secured and that is not: (a) an Administrative Claim; (b) a Chapford DIP Facility Claim; (c) a Vida DIP Claim; (d) a DLP Secured Claim; (e) a Priority Tax Claim; (f) an Other Secured Claim; (g) an Other Priority Claim; (h) a Bond Claim; (i) a DLP Entity General Unsecured Claim; or (j) an Intercompany Claim; *provided*, that, for the avoidance of doubt, a Claim in the amount of \$2,750.00 or less that would otherwise be a General Unsecured Claim shall be treated as a GUC Convenience Claim for purposes of this Plan.

88. “Governmental Unit” shall have the meaning set forth in section 101(27) of the Bankruptcy Code.

89. “GUC Convenience Claim” means an Allowed Claim in an amount greater than \$0.01 but less than or equal to \$2,750.00, that would otherwise qualify as a General Unsecured Claim; *provided*, that any Holder of an Allowed General Unsecured Claim may elect to have such Claim reduced to \$2,750.00 and treated as an Allowed GUC Convenience Claim for purposes of this Plan; *provided, further*, that, notwithstanding the foregoing, the total GUC Convenience Claims shall not exceed \$150,000 in the aggregate.

90. “GWGH” means Debtor GWG Holdings, Inc.

91. “GWG Life” means Debtor GWG Life, LLC.

92. “Holder” means any Entity holding a Claim or an Interest.

93. “Holder Notices” means the Indirect Holder Notices and Direct Holder Notices distributed by the Notice and Solicitation Agent at the direction of the Debtors pursuant to the Bondholder Claim Procedures Order.

94. “Impaired” means, with respect to a Class of Claims or Interests, a Class of Claims or Interests that is impaired within the meaning of section 1124 of the Bankruptcy Code.

95. “Indenture” means, collectively, the A&R Indenture, the 2018 Supplemental Indenture, and the 2020 Supplemental Indenture.

96. “Indenture Diminution Claims” means any Claims of the Indenture Trustee asserted on account of the decrease in value of the Indenture Trustee’s interest in the collateral securing the obligations under the Indenture, arising from the “Adequate Protection Liens” granted to the Indenture Trustee pursuant to the Chapford Final DIP Order and the Final Vida Order. On the Effective Date, the Indenture Diminution Claims shall be deemed an Allowed Administrative Claim in the amount as agreed by the Debtors, the Indenture Trustee, and the Creditor Proponents, or as determined by the Court, in the event such parties are unable to reach an agreement as to the amount during further mediation.

97. “Indenture Documents” means the Indenture, the Public L Bonds, the Seller Trust L Bonds, and the Liquidity Bonds, and any amendments, modifications, or supplements thereto, and any notes, certificates, agreements, security agreements, documents, and instruments related thereto or executed in connection therewith.

98. “Indenture Fee and Expense Claims” means any Claims of the Indenture Trustee payable pursuant to Article IV.T hereof, Article IV.L hereof, or the Indenture Documents, for its reasonable and documented fees and expenses and for indemnity, subrogation, and contribution, including, without limitation, attorneys’ fees and expenses, arising under or in connection with the Indenture Documents, including in its capacity as collateral agent thereunder, whether before or after April 20, 2022 or before or after the Effective Date; *provided*, that, after the Effective Date, the Indenture Trustee shall not be able to assert any Claim against the Debtors or the Wind Down Debtors (except as otherwise provided in this Plan).

99. “Indenture Trustee” means Bank of Utah, in its capacity as the Indenture Trustee under the Indenture.

100. “Indenture Trustee Charging Lien” means any Lien or other priority of payment to which the Indenture Trustee is entitled under the Indenture Documents, against distributions to be made to Holders of Claims under the Indenture Documents, for payment of any Indenture Fee and Expense Claims. For the avoidance of doubt, nothing contained in this Plan is intended to create or expand any such Lien (including its priority) beyond what is provided under the Indenture Documents and authorized and/or enforceable under applicable law.

101. “Independent Director Fee Claims” means all unpaid fees and expenses as of the Effective Date due to the Independent Directors, the DLP Independent Directors, or David F. Chavenson pursuant to their respective agreements with the Debtors, as authorized by the CRO/ID Order or otherwise. On the Effective Date, the Independent Director Fee Claims shall be deemed Allowed Administrative Claims.

102. “Independent Directors” means Jeffrey S. Stein and Anthony R. Horton.

103. “Indirect Holder Notices” shall have the meaning set forth in the Bondholder Claim Procedures Order.

104. “Initial Litigation Trust Assets” means the following assets, which will ultimately vest in the Litigation Trust free and clear of all liens, claims, interests, and encumbrances on the Effective Date: (a) the Initial Litigation Trust Funding Amount; (b) the Retained Causes of Action; (c) the Debtors’ interests in the D&O Liability Insurance Policies that provide coverage prior to April 20, 2022; and (d) the Debtors’ interests in the proceeds of such policies and the Debtors’ entitlements and rights to payments thereunder.

105. “Initial Litigation Trust Funding Amount” means an amount equal to \$3 million in Cash.

106. “Intercompany Claim” means any Claim against a Debtor held by another Debtor.

107. “Intercompany Interest” means any Interest in one Debtor held by another Debtor.

108. “Interest” means any equity security (as defined in section 101(16) of the Bankruptcy Code) in any Debtor outstanding immediately prior to the applicable Petition Date, including any options, warrants, or other rights with respect thereto, or any other instruments evidencing an ownership interest in any of the Debtors and the rights of any Entity to purchase or demand the issuance of any of the foregoing, including: (a) redemption, conversion, exchange, voting, participation, and dividend rights (including any rights in respect of accrued and unpaid dividends); (b) liquidating preferences; and (c) stock options and warrants.

109. “Interim Compensation Order” means the *Corrected Order (I) Establishing Procedures for Interim Compensation and Reimbursement of Expenses for Professionals and (II) Granting Related Relief* [Dkt. No. 378].

110. “Investigations Committee” means the Investigations Committee formed pursuant to the Resolutions of the Board of Directors of GWGH, dated June 19, 2022 (as subsequently amended and restated on July 13, 2022 and July 17, 2022).

111. “Judicial Code” means title 28 of the United States Code, 28 U.S.C. §§ 1-4001.

112. “LBM” means L Bond Management, LLC.

113. “LBM L Bond Claims” shall mean all amounts owed by the Debtors on Claims held by the following trusts for principal or interest evidenced by, arising under, or in connection with the Indenture as of April 20, 2022: The LT-1 Exchange Trust (c/o MHT Financial LLC), The LT-2 Exchange Trust, The LT-3 Exchange Trust, The LT-4 Exchange Trust, The LT-5 Exchange Trust, The LT-6 Exchange Trust, The LT-7 Exchange Trust, The LT-8 Exchange Trust, The LT-9 Exchange Trust, The LT-12 Exchange Trust, The LT-14 Exchange Trust, The LT-15 Exchange Trust, The LT-16 Exchange Trust, The LT-17 Exchange Trust, The LT-18 Exchange Trust, The LT-19 Exchange Trust, The LT-20 Exchange Trust, The LT-21A Custody Trust, The LT-22A Custody Trust, The LT-23A Custody Trust, The LT-24A Custody Trust, The LT-25A Custody Trust, and The LT-26A Custody Trust. For the avoidance of doubt (and except as provided in Article IV.I hereof), LBM L Bond Claims, including the LBM Subordinated Claims, are deemed Allowed under this Plan, shall be Allowed upon entry of the Confirmation Order, and otherwise constitute Allowed Class 3 Bond Claims.

114. “LBM Released Claims” means any and all civil claims held by the Debtors’ Estates against the LBM Released Parties.

115. “LBM Released Parties” means, collectively, and in each case in their respective capacities as such: (a) LBM; (b) LBM’s managers, employees, agents, attorneys and representatives solely in such capacity and solely for actions taken in such capacity that are related to the acquisition, holding, or disposition of any Seller Trust L Bonds for which LBM acts as agent including the LBM L Bond Claims; (c) the trusts identified in the definition of LBM L Bond Claims, the trustees and trust advisors of such trusts, current officers, directors, and advisors of such trusts, each solely in such capacity and solely for actions taken on behalf of such trusts; and (d) Richard Schmidt and his professionals; *provided, however*, that any release of the LBM Released Claims are to be narrowly construed, and to the extent any LBM Released Parties serve or have served in multiple capacities, such releases do not extend beyond capacities as described above.

116. “LBM Settlement” means the agreement between the Debtors and the Creditor Proponents set forth in Article IV.I hereof.

117. “LBM Subordinated Claims” means, as applicable: (a) where LBM has not timely withdrawn from the settlement described in Article IV.I of this Plan, the portion of the Allowed LBM L Bond Claims equal to fifteen percent (15%) of the total amount of such Claims as of April 20, 2022; or (b) where LBM has timely withdrawn from such settlement, the portion of such Bond Claims, if any, subordinated pursuant to a Final Order of the Bankruptcy Court.

118. “Lien” shall have the meaning set forth in section 101(37) of the Bankruptcy Code.

119. “Litigation Trust” means the litigation trust established on the Effective Date for the purpose of prosecuting or settling the Retained Causes of Action through the distribution of net proceeds thereof to the Wind Down Trust.

120. “Litigation Trust Agreement” means the agreement governing the Litigation Trust, the form and substance of which being subject to the Proponents’ Consent Right, which shall be Filed as part of the Plan Supplement.

121. “Litigation Trust Reconciliation Claims” means Claims or Interests held or Filed by any: (a) defendant in any litigation initiated by the Litigation Trustee or, in consultation with the Wind Down Trustee, Entity against whom the Litigation Trustee expects to initiate litigation; (b) any Broker Dealers; and (c) Holders of LBM L Bond Claims, in the event LBM withdraws from the settlement described in Article IV.I herein.

122. “Litigation Trustee” means Michael I. Goldberg, or such other independent, third-party fiduciary appointed as trustee of the Litigation Trust by the Bondholder Committee in their sole discretion and as identified in the Plan Supplement; *provided*, that, for the avoidance of doubt, the Litigation Trustee shall have no affiliation with any Bondholder Committee member and must not own any Public L Bonds, New WDT Interests, or other Interests in or Securities issued by any of the Debtors. The Litigation Trustee shall, among other things: (a) prosecute and/or settle the Retained Causes of Action; and (b) facilitate distributions as set forth in Section IV.D hereof.

123. “Liquidating Company Exception” has the meaning set forth in Article IV.A.5 of this Plan.

124. “Liquidity Bonds” means the bonds issued pursuant to and under the 2020 Supplemental Indenture.

125. “Minimum Distribution Amount” means \$15,000,000 in Cash.

126. “Mediated Settlement” means the settlement by and among the Debtors and the Creditor Proponents, memorialized in the Mediation Agreement.

127. “Mediation Agreement” means the written agreement entered into by the Debtors and the Creditor Proponents, dated as of March 9, 2023 [Dkt. No. 1518], which is described in further detail in the Disclosure Statement.

128. “Net Cash Proceeds” means with respect to any disposition or monetization by the Wind Down Trustee of any of the Wind Down Trust Assets, including of any interest in Beneficiary or FOXO, the excess, if any, of: (a) the sum of cash and cash equivalents received in connection with such transaction (including any cash or cash equivalents received by way of deferred payment pursuant to, or by monetization of, a note receivable or otherwise, but only as and when so received); less (b) the sum of (i) the reasonable and customary out-of-pocket expenses incurred by the Wind Down Trustee, as applicable, in connection with such transaction and (ii) income taxes reasonably estimated to be actually payable within two years of the date of the relevant transaction as a result of any gain recognized in connection therewith; *provided* that, if the amount of any estimated taxes pursuant to subclause (ii) exceeds the amount of taxes actually

required to be paid in cash in respect of such disposition or monetization, the aggregate amount of such excess shall constitute Net Cash Proceeds.

129. “New Series A1 WDT Interests” shall mean the new beneficial interests in the Wind Down Trust issued to Holders of Allowed Bond Claims in Class 3 (other than Allowed LBM Subordinated Claims) pursuant to this Plan in an amount equal to the amount of the outstanding Allowed Bond Claims (less the amount of the Allowed LBM Subordinated Claims) as of the Petition Date, which shall be satisfied, redeemed, and/or cancelled in full in accordance with the terms and provisions of the New WDT Documents prior to any distributions on account of any New Series A2 WDT Interests, New Series B WDT Interests, New Series C WDT Interests, New Series D WDT Interests, or New Series E WDT Interests, and shall provide for the accrual of interest from April 20, 2022 at a rate of 9% per annum, subject to and in accordance with the waterfall provisions set forth in Article IV.H and Article VI.C hereof. The New Series A1 WDT Interests shall include any New Series A1 WDT Interests issued to the Indenture Trustee on account of any outstanding Indenture Fee and Expense Claims.

130. “New Series A2 WDT Interests” shall mean the new beneficial interests in the Wind Down Trust issued to Holders of Allowed LBM Subordinated Claims in Class 3 pursuant to this Plan in an amount equal to the amount of the Allowed LBM Subordinated Claims, which shall be satisfied, redeemed, and/or cancelled in full in accordance with the terms and provisions of the New WDT Documents prior to any distributions on account of any New Series B WDT Interests, New Series C WDT Interests, New Series D WDT Interests, or New Series E WDT Interests, but following the satisfaction, redemption, and/or cancellation of the New Series A1 WDT Interests, and shall provide for the accrual of interest from April 20, 2022 at a rate of 9% per annum, subject to and in accordance with the waterfall provisions set forth in Article IV.H and Article VI.C hereof.

131. “New Series B WDT Interests” shall mean the new beneficial interests in the Wind Down Trust issued to Holders of Allowed General Unsecured Claims in Class 4(a) pursuant to this Plan in an amount equal to the aggregate amount of Allowed Class 4(a) General Unsecured Claims, which shall be satisfied, redeemed, and/or cancelled in full in accordance with the terms and provisions of the New WDT Documents prior to any distributions on account of any New Series C WDT Interests, New Series D WDT Interests, or New Series E WDT Interests, but following the satisfaction, redemption, and/or cancellation of the New Series A1 WDT Interests and the New Series A2 WDT Interests, subject to and in accordance with the waterfall provisions set forth in Article IV.H and Article VI.C hereof.

132. “New Series C WDT Interests” shall mean the new beneficial interests in the Wind Down Trust issued to Holders of Allowed Series 1 Preferred Interests in Class 8 pursuant to this Plan in an amount equal to the aggregate amount of Allowed Class 8 Series 1 Preferred Interests (based on each Series 1 Preferred Interest having an initial stated value of \$1,000.00 per share), which shall be satisfied, redeemed, and/or cancelled in full in accordance with the terms and provisions of the New WDT Documents on a *pari passu* basis with the New Series D WDT Interests, prior to any distributions on account of any New Series E WDT Interests, but following the satisfaction, redemption, and/or cancellation of the New Series A1 WDT Interests, the New Series A2 WDT Interests, and the New Series B WDT Interests, subject to and in accordance with the waterfall provisions set forth in Article IV.H and Article VI.C hereof.

133. “New Series D WDT Interests” shall mean the new beneficial interests in the Wind Down Trust issued to Holders of Allowed Series 2 Preferred Interests in Class 9 pursuant to this Plan in an amount equal to the aggregate amount of Allowed Class 9 Series 2 Preferred Interests (based on each Series 2 Preferred Interest having an initial stated value of \$1,000.00 per share), which shall be satisfied, redeemed, and/or cancelled in accordance with the terms and provisions of the New WDT Documents on a *pari passu* basis with the New Series C WDT Interests, prior to any distributions on account of any New Series E WDT Interests, but following the satisfaction, redemption, and/or cancellation of the New Series A1 WDT Interests, the New Series A2 WDT Interests, and the New Series B WDT Interests, subject to and in accordance with the waterfall provisions set forth in Article IV.H and Article VI.C hereof.

134. “New Series E WDT Interests” shall mean the new beneficial interests in the Wind Down Trust issued to Holders of Allowed Existing Common Stock in Class 10 pursuant to this Plan in a number equal to the aggregate number of Allowed Class 10 Existing Common Stock. Holders of New Series E WDT Interests shall receive distributions as authorized by the Wind Down Trustee; *provided*, that (a) holders of New Series E WDT Interests shall not be entitled to receive any distributions until all other New WDT Interests have been satisfied, cancelled, and/or redeemed in accordance with the terms and provisions of the New WDT Documents, and (b) nothing herein requires the Wind Down Trustee to authorize any distribution to holders of New Series E WDT Interests.

135. “New WDT Interests” means, collectively, the New Series A1 WDT Interests, the New Series A2 WDT Interests, the New Series B WDT Interests, the New Series C WDT Interests, the New Series D WDT Interests, and the New Series E WDT Interests.

136. “New WDT Documents” means any and all documentation required to implement, issue, and distribute the New WDT Interests, the form and substance of which being subject to the Proponents’ Consent Right, and which documentation may be part of the Wind Down Trust Agreement.

137. “Non-Management Directors” shall mean David F. Chavenson and David de Weese.

138. “Non-Released Parties” shall mean any Entities that are not Released Parties, which Entities shall include, without limitation, Beneficient, its current and former directors and officers (including, without limitation, Bradley K. Heppner, Thomas O. Hicks, Bruce W. Schnitzer, Dennis P. Lockhart, and Peter T. Cangany), HCLP Nominees, L.L.C., the Debtors’ former directors and officers (including, without limitation, Murray Holland and Timothy Evans) in their capacity or capacities as such, and any Entities affiliated with or otherwise related to the foregoing.

139. “Notice and Solicitation Agent” means Donlin, Recano & Company, Inc., in its capacity as such to the Debtors in the Chapter 11 Cases.

140. “Ordinary Course Professional” means an Entity (other than a Professional) retained and compensated by the Debtors in accordance with the Ordinary Course Professionals Order.

141. “Ordinary Course Professionals Order” means the *Order (I) Authorizing the Retention and Compensation of Certain Professionals Utilized in the Ordinary Course of Business and (II) Granting Related Relief* [Dkt. No. 412].

142. “Other Priority Claim” means any Claim against any Debtor entitled to priority in right of payment under section 507 of the Bankruptcy Code, other than an Administrative Claim or a Priority Tax Claim.

143. “Other Secured Claim” means a Secured Claim against any of the Debtors that is not: (a) a Chapford DIP Facility Claim; (b) a Vida DIP Claim; (c) a DLP Secured Claim (otherwise paid in full in Cash before the Effective Date); or (d) a Bond Claim.

144. “Petition Date” means the date on which each of the Debtors commenced the Chapter 11 Cases, as applicable.

145. “Plan” means this *Debtors’ Further Modified Second Amended Joint Chapter 11 Plan*, including the Plan Supplement and all exhibits, supplements, appendices, and schedules, which are incorporated herein by reference and made part of this Plan as if set forth herein, as each may be modified, supplemented, or waived from time to time in accordance with the respective terms thereof.

146. “Plan Supplement” means the compilation of documents and forms of documents, agreements, schedules, and exhibits to this Plan (as may be altered, amended, modified, or supplemented from time to time in accordance with the terms hereof), which may include the following, as applicable and if needed: (a) the identity of the Wind Down Trustee; (b) the identity of the Litigation Trustee; (c) a schedule of the known Retained Causes of Action; (d) a Schedule of Assumed Executory Contracts and Unexpired Leases; (e) the form of Litigation Trust Agreement; (f) the form of Wind Down Trust Agreement; (g) the Wind Down Amount; (h) the form of New WDT Documents, if any; (i) the form of notice of Effective Date; and (j) any other documentation necessary to effectuate or that is contemplated by this Plan. The Debtors shall File the Plan Supplement, which Plan Supplement documents shall be subject to the Proponents’ Consent Right, no later than 5 Business Days before the Voting Deadline. Prior to the Effective Date and in accordance with the terms hereof and subject to the Proponents’ Consent Right, the Plan Supplement may be modified, amended, supplemented, restated, or withdrawn after it is Filed and such changes shall be made publicly available.

147. “Policy Portfolio” means the portfolio of near-duration, intermediate-duration, and long-duration life insurance policies, owned by Debtors DLP IV and DLP VI.

148. “Policy Portfolio Equity Interests” means the direct and indirect equity interests in Portfolio Co., which shall constitute property of the Debtors’ Estates and shall be retained or transferred as described herein.

149. “Portfolio Proceeds Amount” means an amount consisting of the expected net Cash proceeds from the Vida DIP Financing Facility, less: (a) the Estimated Effective Date Shortfall Amount, if any; (b) the Initial Litigation Trust Funding Amount; and (c) the Wind Down Amount.

150. “Portfolio Co.” means, in connection with the Vida DIP Financing Facility and the Vida Exit Financing Facility, the new successor entity, to be created after Confirmation, to which Debtors DLP IV and DLP VI shall transfer the Policy Portfolio.

151. “Priority Tax Claim” means any Claim of a Governmental Unit of the kind specified in section 507(a)(8) of the Bankruptcy Code.

152. “Professional” means an Entity: (a) retained in the Chapter 11 Cases pursuant to a Final Order in accordance with sections 327, 363, or 1103 of the Bankruptcy Code and to be compensated for services rendered before or on the Confirmation Date, pursuant to sections 327, 328, 329, 330, 363, and 331 of the Bankruptcy Code; or (b) awarded compensation and reimbursement by the Bankruptcy Court pursuant to section 503(b)(4) of the Bankruptcy Code, for the avoidance of doubt, a “Professional” shall not include any Ordinary Course Professional.

153. “Professional Fee Escrow Account” means an interest-bearing escrow account to hold and maintain an amount of Cash equal to the Professional Fee Escrow Amount in the manner described in Article II.B of this Plan, which account shall be established by the Debtors on or before the Effective Date and held in trust for the Professionals solely for the purpose of paying Allowed and unpaid Accrued Professional Compensation Claims.

154. “Professional Fee Escrow Amount” means the aggregate Accrued Professional Compensation Claims through the Confirmation Date, as estimated in accordance with Article II.B of this Plan.

155. “Proof of Claim” means a proof of Claim Filed against any of the Debtors in the Chapter 11 Cases.

156. “Proof of Interest” means a proof of Interest Filed against any of the Debtors in the Chapter 11 Cases.

157. “Public L Bonds” means the bonds issued in a registered public offering under the Securities Act pursuant to and under the A&R Indenture.

158. “Proponents’ Consent Right” has the meaning set forth in Article I.G of this Plan.

159. “Reinstate” means reinstate, reinstated, or reinstatement with respect to Claims and Interests, that the Claim or Interest shall be rendered Unimpaired in accordance with section 1124 of the Bankruptcy Code. “Reinstated” and “Reinstatement” shall be correlative meanings.

160. “Released Party” means, collectively, and in each case in their respective capacities as such and subject to the limitations set forth in Article VIII.C hereof: (a) (i) the Debtors and the Wind Down Debtors, (ii) Vida, (iii) the Bondholder Committee and each of its members, (iv) Anthony R. Horton, in his capacities as an Independent Director and director of the Debtors, (v) Jeffrey S. Stein, in his capacities as an officer, an Independent Director, and a director of the Debtors, (vi) Michael A. Tucker, in his capacity as an officer of the Debtors, (vii) the DLP Independent Directors, (viii) FTI Consulting, Inc., (ix) PJT Partners LP, and (x) any other Professional retained by the Debtors, the Independent Directors, the DLP Independent Directors, or the Bondholder Committee by order of the Bankruptcy Court in the Chapter 11 Cases or any

professional retained by any of the members of the Bondholder Committee, each in such capacity; and (b) solely to the extent and on the terms and conditions set forth in this Plan, the LBM Released Parties.

161. “Retained Causes of Action” means all Avoidance Actions, all Causes of Action set forth on a schedule in the Plan Supplement, the form and substance of which being subject to the Proponents’ Consent Right, and any other Causes of Action belonging to the Debtors or their Estates that are not released pursuant to this Plan or other Final Order, and, for the avoidance of doubt, all entitlements, proceeds and rights to payments with respect to any of the foregoing; *provided*, that Retained Causes of Action shall not include any Causes of Action that the Debtors may have against the DLP Independent Directors or their Professionals (in their capacities as such).

162. “Schedule of Assumed Executory Contracts and Unexpired Leases” means the schedule of certain Executory Contracts and Unexpired Leases to be assumed or assumed and assigned by the Debtors pursuant to the Plan, as set forth in the Plan Supplement, in form and substance reasonably acceptable to the Creditor Proponents.

163. “Schedules” means, collectively, the schedules of assets and liabilities, schedules of Executory Contracts and Unexpired Leases, and statements of financial affairs Filed by the Debtors pursuant to section 521 of the Bankruptcy Code and the applicable Bankruptcy Rules, as such Schedules may be amended, modified, or supplemented from time to time.

164. “SEC” means the United States Securities and Exchange Commission.

165. “Secured” means when referring to a Claim: (a) secured by a Lien on property in which the applicable Estate has an interest, which Lien is valid, perfected, and enforceable pursuant to applicable law or by reason of a Bankruptcy Court order, or that is subject to setoff pursuant to section 553 of the Bankruptcy Code, to the extent of the value of the creditor’s interest in such Estate’s interest in such property or to the extent of the amount subject to setoff, as applicable, as determined pursuant to section 506(a) of the Bankruptcy Code and Bankruptcy Rule 3012, as applicable; or (b) Allowed pursuant to the Plan as a Secured Claim.

166. “Securities Act” means the U.S. Securities Act of 1933, as amended, 15 U.S.C. §§ 77a–77aa, and the rules and regulations promulgated thereunder.

167. “Securities Exchange Act” means the U.S. Securities Exchange Act of 1934, as amended, §§ 78a-78qq, and the rules and regulations promulgated thereunder.

168. “Security” shall have the meaning set forth in section 101(49) of the Bankruptcy Code.

169. “Seller Trust L Bonds” means the bonds issued pursuant to and under the 2018 Supplemental Indenture.

170. “Series 1 Preferred Interests” means the redeemable preferred shares issued by Debtor GWGH pursuant to that certain Registration Statement on Form S-1 filed pursuant to the Securities Act and declared effective by the SEC on October 30, 2015, with an initial stated value of \$1,000.00 per share.

171. “Series 2 Preferred Interests” means the redeemable preferred shares issued by Debtor GWGH pursuant to that certain Registration Statement on Form S-1 filed pursuant to the Securities Act and declared effective by the SEC on February 14, 2017, with an initial stated value of \$1,000.00 per share.

172. “Shared Services Agreement” means the Shared Services Agreement dated May 27, 2020, entered into by Debtor GWGH and Beneficient, pursuant to which Beneficient provides certain services to Debtor GWGH.

173. “Special Committee” means the Special Committee formed pursuant to the Resolutions of the Board of Directors of GWGH, dated June 19, 2022 (as subsequently amended and restated on July 13, 2022 and July 17, 2022).

174. “U.S. Trustee” means the Office of the United States Trustee for the Southern District of Texas.

175. “Unexpired Lease” means a lease of nonresidential real property to which one or more of the Debtors is a party that is subject to assumption, assumption and assignment, or rejection under sections 365 or 1123 of the Bankruptcy Code.

176. “Unimpaired” means, with respect to a Class of Claims or Interests, a Claim or an Interest that is unimpaired within the meaning of section 1124 of the Bankruptcy Code.

177. “United States” means the United States of America, its agencies, departments, or agents.

178. “Vida” means Vida Capital.

179. “Vida DIP Claims” means any and all Claims for principal, interest, fees, costs, expenses, disbursements, and any and all other obligations of any kind under the Vida DIP Financing Facility, owing as of the Effective Date.

180. “Vida DIP Financing Facility” means the replacement debtor-in-possession financing facility obtained by the Debtors and approved by the Bankruptcy Court pursuant to the Final Vida Order.

181. “Vida Exit Financing Facility” means the exit financing facility obtained by Portfolio Co., pursuant to this Plan.

182. “Vida Exit Financing Facility Documents” means the agreements memorializing the Vida Exit Financing Facility, and any amendments, modifications, or supplements thereto, and together with any related notes, certificates, agreements, intercreditor agreements, security agreements, mortgages, deeds of trust, documents, and instruments (including any amendments, restatements, supplements, or modifications of any of the foregoing) related to or executed in connection with the Vida Exit Financing Facility; *provided*, that the form and substance of the Vida Exit Financing Facility Documents shall be in form and substance subject to the Proponents’ Consent Right, it being understood that the documents that were Filed at [Dkt. No. 975] are in

substantially final form from the Debtors' perspective and shall be the starting point for Vida Exit Financing Facility Documents.

183. “Wind Down Amount” means an amount set forth in the Plan Supplement to initially fund the Wind Down Debtors, as agreed to by the Debtors and the Creditor Proponents, subject to the Proponents' Consent Right.

184. “Wind Down Budget” means a budget setting forth the basis for, and proposed uses of, the Wind Down Amount.

185. “Wind Down Debtors” means, collectively, a Debtor or any successor or assign thereto, by merger, consolidation, amalgamation, or otherwise, on and after the Effective Date, including any new entity established in connection with the implementation of the Wind Down Transactions (which, for the avoidance of doubt, shall include Portfolio Co.).

186. “Wind Down Documents” means this Plan, the Disclosure Statement, the Confirmation Order, the Plan Supplement, and the various agreements and other documentation formalizing this Plan.

187. “Wind Down Transactions” means the transactions that the Wind Down Trustee determines to be necessary or appropriate to implement the terms of this Plan, and that ultimately result in the dissolution or other termination of the Debtors or Wind Down Debtors, as applicable.

188. “Wind Down Trust” means the liquidation trust established on the Effective Date for the purpose of monetizing the Wind Down Trust Assets.

189. “Wind Down Trust Agreement” means the agreement governing the Wind Down Trust, which shall be Filed as part of the Plan Supplement.

190. “Wind Down Trust Assets” means the following assets, which will ultimately vest in the Wind Down Trust free and clear of all liens, claims, interests, and encumbrances on the Effective Date: (a) the Policy Portfolio Equity Interests; (b) the Debtors' interests in Beneficient; (c) the Debtors' interests in FOXO; (d) all reversionary and beneficial interests in the Litigation Trust; and (e) any remaining Assets of the Debtors', other than the Initial Litigation Trust Assets.

191. “Wind Down Trustee” means Elizabeth C. Freeman or any Affiliate of Elizabeth C. Freeman identified in the Plan Supplement who shall, among other things: (a) be the ultimate governing authority for the Wind Down Debtors; (b) make or facilitate distributions to Holders of Allowed Claims under the Plan; (c) receive for distribution, or direct the distribution of, the proceeds from the realization of the Initial Litigation Trust Assets pursuant to the provisions of this Plan; and (d) oversee and make all decisions with respect to the wind down, dissolution, and liquidation of the Wind Down Debtors and the Wind Down Trust after the Effective Date, including, without limitation, the monetization of the Debtors' Assets (other than Initial Litigation Trust Assets).

B. Rules of Interpretation.

For purposes of the Plan: (1) in the appropriate context, each term, whether stated in the singular or the plural, shall include both the singular and the plural, and pronouns stated in the masculine, feminine, or neuter gender shall include the masculine, feminine, and the neuter gender; (2) unless otherwise specified, any reference herein to a contract, lease, instrument, release, indenture, or other agreement or document being in a particular form or on particular terms and conditions means that the referenced document shall be substantially in that form or substantially on those terms and conditions; (3) unless otherwise specified, any reference herein to an existing document, schedule, or exhibit, whether or not Filed, having been Filed or to be Filed shall mean that document, schedule, or exhibit, as it may thereafter be amended, modified, or supplemented; (4) any reference to an Entity as a Holder of a Claim or Interest includes that Entity's successors; (5) unless otherwise specified, all references herein to "Articles" are references to Articles hereof or hereto; (6) unless otherwise specified, all references herein to exhibits are references to exhibits in the Plan Supplement; (7) unless otherwise specified, the words "herein," "hereof," and "hereto" refer to the Plan in its entirety rather than to a particular portion of the Plan; (8) subject to the provisions of any contract, certificate of incorporation, by-law, instrument, release, or other agreement or document entered into in connection with the Plan, the rights and obligations arising pursuant to the Plan shall be governed by, and construed and enforced in accordance with the applicable federal law, including the Bankruptcy Code and Bankruptcy Rules; (9) captions and headings to Articles are inserted for convenience of reference only and are not intended to be a part of or to affect the interpretation of the Plan; (10) unless otherwise specified herein, the rules of construction set forth in section 102 of the Bankruptcy Code shall apply to the Plan; (11) any term used in capitalized form herein that is not otherwise defined but that is used in the Bankruptcy Code or the Bankruptcy Rules shall have the meaning assigned to that term in the Bankruptcy Code or the Bankruptcy Rules, as the case may be; (12) all references to docket numbers of documents Filed in the Chapter 11 Cases are references to the docket numbers under the Bankruptcy Court's CM/ECF system; (13) all references to statutes, regulations, orders, rules of courts, and the like shall mean as amended from time to time, and as applicable to the Chapter 11 Cases, unless otherwise stated; and (14) any immaterial effectuating provisions may be interpreted in such a manner that is consistent with the overall purpose and intent of the Plan all without further notice to or action, order, or approval of the Bankruptcy Court or any other Entity, provided that no effectuating provision shall be deemed immaterial if it has any substantive legal or economic effect on any party. References in the Plan to the Debtors shall mean the Debtors or any successor thereto, by merger, consolidation, or otherwise, on or after the Effective Date, as applicable.

C. Computation of Time.

The provisions of Bankruptcy Rule 9006(a) shall apply in computing any period of time prescribed or allowed in the Plan or Confirmation Order. If the date on which a transaction may occur pursuant to the Plan shall occur on a day that is not a Business Day, then such transaction shall instead occur on the next succeeding Business Day.

D. Governing Law.

Unless a rule of law or procedure is supplied by federal law (including the Bankruptcy Code and Bankruptcy Rules) or unless otherwise specifically stated, the laws of the State of New

York, without giving effect to the principles of conflict of laws (except for Sections 5-1401 and 5-1402 of the General Obligations Law of the State of New York), shall govern the rights, obligations, construction, and implementation of the Plan, any agreements, documents, instruments, or contracts executed or entered into in connection with the Plan (except as otherwise set forth in those agreements, in which case the governing law of such agreement shall control); *provided* that corporate or limited liability company governance matters relating to the Debtors or the Wind Down Debtors shall be governed by the laws of the state of incorporation or formation (as applicable) of the applicable Debtor or Wind Down Debtor, as applicable.

E. Reference to Monetary Figures.

All references in the Plan to monetary figures shall refer to the legal tender of the United States, unless otherwise expressly provided.

F. Controlling Document.

Except as set forth in the Plan, to the extent that any provision of any other Wind Down Document or any document or other exhibits, schedules, appendices, supplements, or amendments of any document referenced in the Plan conflict with or are in any way inconsistent with any provision of the Plan, the Plan shall govern and control; *provided* that, with respect to any conflict or inconsistency between the Plan and the Wind Down Trust Agreement and/or the Litigation Trust Agreement (each in the form executed on or before the Effective Date), such Wind Down Trust Agreement and/or Litigation Trust Agreement, as applicable, shall govern; *provided, further*, that, with respect to any conflict or inconsistency between the Plan and the Plan Supplement (including the Wind Down Trust Agreement and the Litigation Trust Agreement) on the one hand, and the Confirmation Order on the other hand, the Confirmation Order shall govern.

G. Proponents' Consent Right.

The Debtors submit this Plan with the Debtors and the Creditor Proponents co-proposing this Plan within the meaning of section 1129 of the Bankruptcy Code. Per the Mediation Agreement, the Debtors and the Creditor Proponents have the right, acting separately (the "Proponents' Consent Right") to review and consent to the form and substance of the: (1) the Disclosure Statement accompanying this Plan; (2) this Plan; and (3) the Plan Supplement, including trust agreements and other applicable documents. Per the Mediation Agreement, the scope of the Proponents' Consent Right is: (a) to ensure that such documents are consistent with, and can effectuate the settlement memorialized in the Mediation Agreement; and (b) to address issues not explicitly covered by the Mediation Agreement but are customary or required for a plan of reorganization.

Following the Filing of this Plan, submitted by the Debtors, the Bondholder Committee, and LBM as co-proponents, dated as of March 27, 2023, in the event the Debtors and the Creditor Proponents cannot agree to the form and substance of any document in connection with this Plan (and such document is subject to the Proponents' Consent Rights or other consent rights hereunder) or any decision which requires the consent of the Creditor Proponents, by the applicable deadline for Filing such document hereunder, any such dispute shall be submitted to the mediator, Judge David Jones. To the extent of any remaining disputes following such mediation, then, pending

final resolution thereof, any of the Debtors and the Creditor Proponents may File its own version of any such disputed document by the applicable deadline therefor. In such event: (x) the Filing of the competing versions of any such disputed document shall be deemed to have satisfied any such Filing deadline hereunder; (y) the Debtors and the Creditor Proponents shall continue as co-proponents of this Plan for all purposes; and (z) the final form of any such disputed document will be subsequently resolved through either mediation with Judge Jones or by order of the Bankruptcy Court.

For the avoidance of doubt, this Article I.G applies to and supersedes (in the event of conflict) every provision of this Plan that refers to any consent right of the Creditor Proponents (except with respect to the consent right described in Article X.C hereof). Further, in the event of any dispute, and for the avoidance of doubt, the Debtors and the Creditor Proponents agree to support this Plan (including any amended plan) and any document comprising the Plan Supplement, provided that the form and substance of such document is resolved, if necessary, pursuant to the dispute resolution mechanic set forth above.

ARTICLE II.
ADMINISTRATIVE CLAIMS, ACCRUED PROFESSIONAL FEE COMPENSATION
CLAIMS, DIP CLAIMS, PRIORITY TAX CLAIMS, INDENTURE DIMINUTION
CLAIMS, AND SUBSTANTIAL CONTRIBUTION CLAIMS

A. *Administrative Claims.*

Except as otherwise agreed to by the Holder of an Allowed Administrative Claim and the Debtors or Wind Down Debtors or as provided herein, on the Administrative Claims Payment Date (or within a reasonable period of time after such Claims become Allowed Claims), each Holder of an Allowed Administrative Claim shall receive payment in full in Cash in full and final satisfaction, settlement, discharge, and release of such Allowed Administrative Claim in accordance with the following: (1) if an Administrative Claim is Allowed on or prior to the Effective Date, on the Effective Date or as soon as reasonably practicable thereafter (or, if not then due, when such Allowed Administrative Claim is due or as soon as reasonably practicable thereafter); (2) if such Administrative Claim is not Allowed as of the Effective Date, no later than 30 days after the date on which an order Allowing such Administrative Claim becomes a Final Order, or as soon as reasonably practicable thereafter; (3) if such Allowed Administrative Claim is based on liabilities incurred by the Debtors in the ordinary course of their business after the applicable Petition Date in accordance with the terms and conditions of the particular transaction giving rise to such Allowed Administrative Claim without any further action by the Holder of such Allowed Administrative Claim; (4) at such time and upon such terms as may be agreed upon by such Holder and the Debtors or the Wind Down Debtors, as applicable; or (5) at such time and upon such terms as set forth in an order of the Bankruptcy Court.

EXCEPT AS OTHERWISE PROVIDED BY THIS PLAN, THE CONFIRMATION ORDER, OR A FINAL ORDER PREVIOUSLY ENTERED BY THE BANKRUPTCY COURT (INCLUDING THE FINAL VIDA ORDER), UNLESS PREVIOUSLY FILED, REQUESTS FOR PAYMENT OF ADMINISTRATIVE CLAIMS MUST BE FILED AND SERVED ON THE DEBTORS (OR THE WIND DOWN DEBTORS, AS APPLICABLE) NO LATER THAN THE CLAIMS BAR DATE APPLICABLE TO ADMINISTRATIVE

CLAIMS PURSUANT TO THE PROCEDURES SPECIFIED IN THE CONFIRMATION ORDER AND THE NOTICE OF THE EFFECTIVE DATE; *PROVIDED*, THAT THE FOREGOING SHALL NOT APPLY TO ACCRUED PROFESSIONAL COMPENSATION CLAIMS, INDEPENDENT DIRECTOR FEE CLAIMS, THE INDENTURE DIMINUTION CLAIMS, THE ALLOWED AHC SUBSTANTIAL CONTRIBUTION CLAIM, OR CLAIMS ARISING UNDER SECTION 503(b)(1)(D) OF THE BANKRUPTCY CODE.

HOLDERS OF ADMINISTRATIVE CLAIMS THAT ARE REQUIRED TO FILE AND SERVE A REQUEST FOR PAYMENT OF SUCH ADMINISTRATIVE CLAIMS BY THE CLAIMS BAR DATE APPLICABLE TO ADMINISTRATIVE CLAIMS THAT DO NOT FILE AND SERVE SUCH A REQUEST BY THE CLAIMS BAR DATE APPLICABLE TO ADMINISTRATIVE CLAIMS SHALL BE FOREVER BARRED, ESTOPPED, AND ENJOINED FROM ASSERTING SUCH ADMINISTRATIVE CLAIMS AGAINST THE DEBTORS, THE WIND DOWN DEBTORS, THE DEBTORS' ESTATES, OR THEIR RESPECTIVE PROPERTY, AND SUCH ADMINISTRATIVE CLAIMS SHALL BE DEEMED DISCHARGED AS OF THE EFFECTIVE DATE. ALL SUCH CLAIMS SHALL BE SUBJECT TO THE PERMANENT INJUNCTION SET FORTH IN ARTICLE VIII.G HEREIN.

B. Accrued Professional Compensation Claims.

1. Professional Fee Escrow Account.

No later than one Business Day prior to the Effective Date, the Debtors shall fund the Professional Fee Escrow Account with the Debtors' Cash on hand in the amount of the aggregate Professional Fee Escrow Amount for all Professionals; *provided* that each Professional's respective share of the Professional Fee Escrow Account shall be reduced, on a dollar-for-dollar basis, by any unused retainer held by such Professional as of the Effective Date.² The Professional Fee Escrow Account shall be maintained in trust for the Professionals and the funds held in the Professional Fee Escrow Account shall not be considered property of the Debtors' Estates or any successor to the Debtors; *provided* that, notwithstanding the foregoing, the Wind Down Trust shall have a reversionary interest in the excess, if any, of the amount of the Professional Fee Escrow Account over the aggregate Allowed Accrued Professional Compensation Claims to be paid from the Professional Fee Escrow Account, and such excess shall be paid to the Wind Down Debtors

² For the avoidance of doubt, nothing contained in this Plan shall be deemed to resolve any of the issues relating to the payment of fees and expenses for services rendered by Willkie Farr & Gallagher, LLP prior to the Petition Date, including with respect to all Cash held as a retainer by the Debtors or Willkie Farr & Gallagher, LLP pursuant to the *Order Modifying the Automatic Stay and Authorizing the Use of Estate Property, to the Extent Applicable, to Allow Payment, Reimbursement and/or Advancement of Defense Costs Under the Insurance Policies* [Dkt. No. 754] (the "D&O Insurance Order") and the *Stipulation and Agreed Order Regarding the Order Modifying the Automatic Stay and Authorizing Use of Estate Property, to the Extent Applicable, to Allow Payment, Reimbursement and/or Advancement of Defense Costs Under Insurance Policies* [Dkt. No. 825]. In accordance with the D&O Insurance Order, any and all such issues remain subject to resolution through either (i) further order of the Bankruptcy Court or (ii) agreement between the Debtors (or, if after the Effective Date, the Wind Down Trustee), Willkie Farr & Gallagher, LLP, and the Bondholder Committee (or, if after the Effective Date, the Litigation Trustee).

(and distributed to the Wind Down Trust, if determined by the Wind Down Trustee) without any further notice to or action, order, or approval of the Bankruptcy Court or any other Entity.

2. Final Fee Applications and Payment of Accrued Professional Compensation Claims.

All final requests for payment of Claims of a Professional for services rendered and reimbursement of expenses incurred prior to the Confirmation Date shall be Filed no later than the first Business Day that is 60 days after the Confirmation Date. After notice and an opportunity for a hearing in accordance with the procedures established by the Bankruptcy Code and prior Bankruptcy Court orders, the Allowed amounts of such Accrued Professional Compensation Claims shall be determined by the Bankruptcy Court. The amount of Accrued Professional Compensation Claims owing to the applicable Professionals shall be paid in Cash to such Professionals from funds held in the Professional Fee Escrow Account after such Claims are Allowed by a Final Order. After all Accrued Professional Compensation Claims have been paid in full, the Final Order Allowing such Accrued Professional Compensation Claims shall direct the escrow agent to return any excess amounts to the Wind Down Trustee without further notice to or action, order, or approval of the Bankruptcy Court or any other Entity.

3. Estimate of Professional Fee Compensation Claims.

To receive payment for unbilled fees and expenses incurred through the Confirmation Date, the Professionals shall provide a reasonable and good faith estimate of their Accrued Professional Compensation Claims before and as of the Confirmation Date and shall deliver such estimate to the Debtors no later than three Business Days before the Confirmation Date; *provided*, that such estimate shall not be considered an admission with respect to the fees and expenses of such Professional and such Professionals are not bound to any extent by the estimates. If a Professional does not provide an estimate, the Debtors may estimate the unbilled fees and expenses of such Professional; *provided, further*, that such estimate shall not be binding or considered an admission with respect to the fees and expenses of such Professional.

4. Post-Confirmation Fees and Expenses.

Except as otherwise specifically provided in this Plan, from and after the Confirmation Date, the Debtors shall, in the ordinary course of business and without any further notice to or action, order, or approval of the Bankruptcy Court, pay in Cash the reasonable and documented legal, professional, or other fees and expenses related to implementation and Consummation of the Plan incurred by the Debtors or the Bondholder Committee; *provided*, that each Entity seeking such payment shall promptly provide copies of its invoices to the Debtors or the Wind Down Trustee, as applicable, and the Bondholder Committee, and the Bankruptcy Court shall have exclusive jurisdiction over any objections raised to the amount of the fees and expenses proposed to be paid, which objections may only be raised within 14 days after receipt thereof. In the event that within 14 days from receipt of such invoices, the Debtors or the Wind Down Trustee, as applicable, or the Bondholder Committee raises an objection to a particular invoice, and the parties are unable to resolve any dispute regarding the fees and expenses included in such invoice, the Bankruptcy Court shall hear and determine such dispute. Upon the Confirmation Date, any requirement that Professionals and Ordinary Course Professionals comply with sections 327

through 331 and 1103 of the Bankruptcy Code, the Interim Compensation Order, or the Ordinary Course Professionals Order, in seeking retention or compensation for services rendered after such date shall terminate, and the Debtors or the Wind Down Trustee, as applicable, may employ and pay any Professional or Ordinary Course Professional in the ordinary course of business without any further notice to or action, order, or approval of the Bankruptcy Court. Furthermore, as of the date one day prior to the Effective Date, the obligation of any Ordinary Course Professional to File a fee application pursuant to the Ordinary Course Professionals Order shall be deemed waived, and, on the Effective Date, the Debtors or the Wind Down Trustee, as applicable, may pay any Ordinary Court Professional for fees incurred or accrued after the Effective Date in the ordinary course of business without any further notice to or action, order, or approval of the Bankruptcy Court.

C. Chapford DIP Facility Claims.

On or prior to the Effective Date, and to the extent each such Chapford DIP Facility Claims have not previously been satisfied in full in connection with the consummation of the Vida DIP Financing Facility or otherwise, each Holder of an Allowed Chapford DIP Facility Claim shall receive payment in full in Cash; *provided, however*, for the avoidance of doubt, the Chapford DIP Facility Claims shall not include the purported Alternate Stalking Horse Fee, as defined and referenced in the Chapford Final DIP Order (including any professional fees and expenses relating in any manner to the assertion of the purported Alternate Stalking Horse Fee).

D. Vida DIP Claims.

No later than the Effective Date, the Vida DIP Claims will be deemed satisfied in connection with the Debtors' exercise of the exit financing option and upon the closing under the Vida Exit Financing Facility Documents.

E. DLP Secured Claims.

All Allowed DLP Secured Claims will be satisfied by payment in full in Cash on or prior to the Effective Date from proceeds of the Vida DIP Financing Facility; *provided*, that, notwithstanding the foregoing, to the extent that all Allowed DLP Secured Claims are not paid in full in cash before the Effective Date, they shall be treated as Other Secured Claims. Any Disputed portion of the DLP Secured Claims shall be treated in accordance with Article VII hereof.

F. Indenture Diminution Claims.

Any Allowed Indenture Diminution Claims will be satisfied by one or more payments in Cash after the Effective Date from proceeds realized by the Litigation Trust, pursuant to and in accordance with Article VI.C hereof.

G. Priority Tax Claims.

Except to the extent that a Holder of an Allowed Priority Tax Claim agrees to a less favorable treatment, in full and final satisfaction, settlement, and release of and in exchange for each Allowed Priority Tax Claim, each Holder of such Allowed Priority Tax Claim shall be treated in accordance with the terms set forth in section 1129(a)(9)(C) of the Bankruptcy Code.

H. Allowed AHC Substantial Contribution Claim.

In full and final resolution of any claims that the Ad Hoc Broker/Dealer Committee could assert for making a substantial contribution to these Chapter 11 Cases, the Debtors agree to pay the actual and reasonable fees and expenses of the Ad Hoc Broker/Dealer Committee not to exceed \$1,000,000.

I. Substantial Contribution Compensation and Expenses.

Any Entity that requests compensation or expense reimbursement for making a substantial contribution in the Chapter 11 Cases pursuant to Bankruptcy Code sections 503(b)(3), (4), and (5) (except with respect to the Allowed AHC Substantial Contribution Claim) must File an application and serve such application on counsel to the Debtors or the Wind Down Debtors, as applicable, and the Bondholder Committee and as otherwise required by the Bankruptcy Court, the Bankruptcy Code, and the Bankruptcy Rules, on or before the Claims Bar Date applicable to Administrative Claims.

**ARTICLE III.
CLASSIFICATION AND TREATMENT OF CLAIMS AND INTERESTS**

In accordance with section 1123(a)(1) of the Bankruptcy Code, the Chapford DIP Facility Claims, the Vida DIP Claims, Administrative Claims, Accrued Professional Fee Compensation Claims, and Priority Tax Claims have not been classified and, thus, are excluded from the Classes of Claims and Interests set forth in Article III of this Plan.

A. Summary of Classification.

A Claim or Interest is classified in a particular Class pursuant to sections 1122 and 1123(a)(1) of the Bankruptcy Code only to the extent that the Claim or Interest qualifies within the description of that Class and is classified in other Classes to the extent that any portion of the Claim or Interest qualifies within the description of such other Classes. Except as provided below, the Plan shall apply as a separate Plan for each of the Debtors. A Claim or Interest is also classified in a particular Class for the purpose of receiving distributions pursuant to the Plan only to the extent that such Claim or Interest is an Allowed Claim or Allowed Interest in that Class and has not been paid, released, disallowed, or otherwise satisfied before the Effective Date.

Class	Claims and Interests	Status	Voting Rights
Class 1	Other Secured Claims	Unimpaired	Deemed to Accept
Class 2	Other Priority Claims	Unimpaired	Deemed to Accept
Class 3	Bond Claims	Impaired	Entitled to Vote
Class 4(a)	General Unsecured Claims	Impaired	Entitled to Vote
Class 4(b)	GUC Convenience Claims	Unimpaired	Deemed to Accept
Class 5	DLP Entity General Unsecured Claims	Unimpaired	Deemed to Accept
Class 6	Intercompany Claims	Impaired	Deemed to Reject
Class 7	Intercompany Interests	Impaired	Deemed to Reject
Class 8	Series 1 Preferred Interests	Impaired	Entitled to Vote

Class 9	Series 2 Preferred Interests	Impaired	Entitled to Vote
Class 10	Existing Common Interests	Impaired	Entitled to Vote

B. Treatment of Claims and Interests.

The treatment provided to each Class relating to each of the Debtors for distribution purposes and voting rights are specified below.

1. Class 1 — Other Secured Claims.

- (a) *Classification:* Class 1 consists of all Other Secured Claims.
- (b) *Treatment:* Except to the extent that a Holder of an Other Secured Claim agrees to a less favorable treatment of its Allowed Claim, on the Effective Date, each Holder of an Allowed Other Secured Claim shall receive, at the Debtors' option: (i) payment in full in Cash; (ii) the collateral securing its Allowed Other Secured Claim; (iii) Reinstatement of its Allowed Other Secured Claim; or (iv) such other treatment rendering its Allowed Other Secured Claim Unimpaired in accordance with section 1124 of the Bankruptcy Code.
- (c) *Voting:* Class 1 is Unimpaired under the Plan. Holders of Claims in Class 1 are conclusively presumed to accept the Plan pursuant to section 1126(f) of the Bankruptcy Code. Therefore, such Holders are not entitled to vote to accept or reject the Plan.

2. Class 2 — Other Priority Claims.

- (a) *Classification:* Class 2 consists of all Other Priority Claims.
- (b) *Treatment:* Except to the extent that a Holder of an Allowed Other Priority Claim agrees to a less favorable treatment of its Allowed Claim, each Holder of an Allowed Other Priority Claim shall receive treatment in a manner consistent with section 1129(a)(9) of the Bankruptcy Code.
- (c) *Voting:* Class 2 is Unimpaired under the Plan. Holders of Claims in Class 2 are conclusively presumed to accept the Plan pursuant to section 1126(f) of the Bankruptcy Code. Therefore, such Holders are not entitled to vote to accept or reject the Plan.

3. Class 3 — Bond Claims.

- (a) *Classification:* Class 3 consists of all Bond Claims.
- (b) *Treatment:* Except to the extent that a Holder of a Bond Claim agrees to a less favorable treatment of its Allowed Claim, each such Holder shall receive, as applicable, as follows:

- (i) each Holder of an Allowed Bond Claim (other than the LBM Subordinated Claims) shall receive, on the Effective Date, its pro rata share of the Portfolio Proceeds Amount, if any; *provided, however,* that the Indenture Fee and Expense Claim shall be satisfied first from the Portfolio Proceeds Amount prior to any such further pro rata distributions in accordance with this subsection (i);
- (ii) each Holder of an Allowed Bond Claim (other than the LBM Subordinated Claims) shall receive, on the Effective Date (or as soon as practicably thereafter), its pro rata share of the New Series A1 WDT Interests. The New Series A1 WDT Interests may be redeemed at any time without penalty at stated value and, pending any such redemption, shall be entitled to Cash distributions pursuant to the priority of payment waterfalls described in Article IV.H and Article VI.C. Any New Series A1 WDT Interests issued to the Indenture Trustee on account of any outstanding Indenture Fee and Expense Claims shall be expressly senior in all respects to any New Series A1 WDT Interests issued to Holders on account of their respective Allowed Class 3 Bond Claims; and
- (iii) each Holder of an Allowed LBM Subordinated Claim shall receive, on the Effective Date, its pro rata share of the New Series A2 WDT Interests. The New Series A2 WDT Interests may be redeemed at any time without penalty at stated value and, pending any such redemption, shall be entitled to Cash distributions, but only pursuant to the priority of payment waterfalls described in Article IV.H and Article VI.C of this Plan.

The pro rata distributions on account of the Allowed Class 3 Bond Claims shall be calculated based upon the sum of the aggregate amount of Allowed Class 3 Bond Claims (less any LBM Subordinated Claims) as of the Petition Date with respect to subsections (i) and (ii) above, and the sum of the aggregate amount of Allowed LBM Subordinated Claims as of the Petition Date with respect to subsection (iii) above, and after accounting for each Holder's receipt of its pro rata share of the Portfolio Proceeds Amount, as applicable.

- (c) *Voting:* Class 3 is Impaired under the Plan. Holders of Allowed Claims in Class 3 are entitled to vote to accept or reject the Plan.

4. Class 4(a) — General Unsecured Claims.

- (a) *Classification:* Class 4(a) consists of all General Unsecured Claims.
- (b) *Treatment:* Except to the extent that a Holder of a General Unsecured Claim agrees to a less favorable treatment of its Allowed Claim, on the Effective Date, each Holder of an Allowed General Unsecured Claim shall receive its

pro rata share of the New Series B WDT Interests. The New Series B WDT Interests may be redeemed at any time without penalty at stated value and, pending any such redemption, shall be entitled to Cash distributions, but only pursuant to the priority of payment waterfalls described in Article IV.H and Article VI.C of this Plan.

- (c) *Voting:* Class 4(a) is Impaired under the Plan. Holders of Allowed Claims in Class 4(a) are entitled to vote to accept or reject the Plan.

5. Class 4(b) — GUC Convenience Claims.

- (a) *Classification:* Class 4(b) consists of all GUC Convenience Claims.
- (b) *Treatment:* Except to the extent that a Holder of a GUC Convenience Claim agrees to a less favorable treatment of its Allowed Claim, in full and final satisfaction, settlement, release, and discharge of, and in exchange for each Allowed GUC Convenience Claim, each Holder thereof shall receive, and the option of the applicable Debtor, either:
 - (i) payment in full in Cash of the due and unpaid portion of its Allowed GUC Convenience Claim on the later of (x) the Effective Date (or as soon thereafter as reasonably practicable), or (y) as soon as practicable after the date such Claim becomes due and payable; or
 - (ii) such other treatment rendering its Allowed GUC Convenience Claim Unimpaired.
- (c) *Voting:* Class 4(b) is Unimpaired under the Plan. Holders of Claims in Class 4(b) are conclusively presumed to accept the Plan pursuant to section 1126(f) of the Bankruptcy Code. Therefore, such Holders are not entitled to vote to accept or reject the Plan.

6. Class 5 — DLP Entity General Unsecured Claims.

- (a) *Classification:* Class 5 consists of all DLP Entity General Unsecured Claims.
- (b) *Treatment:* On the Effective Date or as soon thereafter as such Claim becomes an Allowed Claim, each Holder of an Allowed DLP Entity General Unsecured Claim shall receive payment in full in Cash.
- (c) *Voting:* Class 5 is Unimpaired under the Plan. Holders of Claims in Class 5 are conclusively presumed to accept the Plan pursuant to section 1126(f) of the Bankruptcy Code. Therefore, such Holders are not entitled to vote to accept or reject the Plan.

7. Class 6 — Intercompany Claims.

- (a) *Classification:* Class 6 consists of all Intercompany Claims.
- (b) *Treatment:* Other than the Policy Portfolio Equity Interests, which shall be transferred to the Wind Down Trust as set forth herein, on the Effective Date, any Debtor's Claim against any other Debtor shall be deemed satisfied except to the extent necessary to effectuate the other terms of this Plan.
- (c) *Voting:* Class 6 is Impaired under the Plan. Holders of Claims in Class 6 are deemed to have rejected the Plan pursuant to section 1126(g) of the Bankruptcy Code and are not entitled to vote to accept or reject the Plan.

8. Class 7 — Intercompany Interests.

- (a) *Classification:* Class 7 consists of all Intercompany Interests.
- (b) *Treatment:* On the Effective Date, any Debtor's equity Interests in any other Debtor shall be deemed cancelled except to the extent necessary to effectuate the other terms of this Plan.
- (c) *Voting:* Class 7 is Impaired under the Plan. Holders of Interests in Class 7 are deemed to have rejected the Plan pursuant to section 1126(g) of the Bankruptcy Code and are not entitled to vote to accept or reject the Plan.

9. Class 8 — Series 1 Preferred Interests.

- (a) *Classification:* Class 8 consists of all Series 1 Preferred Interests.
- (b) *Treatment:* On the Effective Date, and in all instances, each Holder of a Series 1 Preferred Interest shall receive its pro rata share of the New Series C WDT Interests. The New Series C WDT Interests may be redeemed at any time without penalty at stated value and, pending any such optional redemption, shall be entitled to Cash distributions, but only pursuant to the priority of payment waterfalls described in Article IV.H and Article VI.C herein. The New Series C WDT Interests shall rank junior in right of payment to the New Series A1 WDT Interests, the New Series A2 WDT Interests, and the New Series B WDT Interests, *pari passu* with the New Series D WDT Interests, and senior to the New Series E WDT Interests.
- (c) *Voting:* Class 8 is Impaired under the Plan. Holders of Allowed Interests in Class 8 are entitled to vote to accept or reject the Plan.

10. Class 9 — Series 2 Preferred Interests.

- (a) *Classification:* Class 9 consists of all Series 2 Preferred Interests.

- (b) *Treatment:* On the Effective Date, and in all instances, each Holder of a Series 2 Preferred Interest shall receive its pro rata share of the New Series D WDT Interests. The New Series D WDT Interests may be redeemed at any time without penalty at stated value and, pending any such optional redemption, shall be entitled to Cash distributions, but only pursuant to the priority of payment waterfalls described in Article IV.H and Article VI.C herein. The New Series D WDT Interests shall rank junior in right of payment to the New Series A1 WDT Interests, the New Series A2 WDT Interests, and the New Series B WDT Interests, *pari passu* with the New Series C WDT Interests, and senior to the New Series E WDT Interests.
- (c) *Voting:* Class 9 is Impaired under the Plan. Holders of Allowed Interests in Class 9 are entitled to vote to accept or reject the Plan.

11. Class 10 — Common Stock in GWGH.

- (a) *Classification:* Class 10 consists of all Holders of Common Stock in GWGH.
- (b) *Treatment:* On the Effective Date, each Holder of Common Stock in GWGH shall receive its pro rata share of the New Series E WDT Interests. The holders of the New Series E WDT Interests shall only be entitled to Cash distributions upon the satisfaction and redemption of all other classes of New WDT Interests, pursuant to the priority of payment waterfalls described in Article IV.H and Article VI.C herein.
- (c) *Voting:* Class 10 is Impaired under the Plan. Holders of Allowed Interests in Class 10 are entitled to vote to accept or reject the Plan.

C. Special Provision Governing Unimpaired Claims.

Except as otherwise provided in the Plan, nothing under the Plan shall affect the rights of the Debtors or Wind Down Debtors in respect of any Unimpaired Claims, including all rights in respect of legal and equitable defenses to or setoffs or recoupments against any such Unimpaired Claims. Unimpaired Claims shall remain Disputed Claims under the Plan until such Claims are Allowed.

D. Elimination of Vacant Classes.

Any Class of Claims or Interests that does not have a Holder of an Allowed Claim or Allowed Interest or a Claim or Interest temporarily Allowed by the Bankruptcy Court as of the date of the Confirmation Hearing shall be deemed eliminated from the Plan for purposes of voting to accept or reject the Plan and for purposes of determining acceptance or rejection of the Plan by such Class pursuant to section 1129(a)(8) of the Bankruptcy Code.

E. Voting Classes; Presumed Acceptance by Non-Voting Classes.

If a Class contains Claims or Interests eligible to vote and no Holders of Claims or Interests eligible to vote in such Class vote to accept or reject the Plan, the Plan shall be presumed accepted by the Holders of such Claims or Interests in such Class; *provided, however*, that such Class shall not qualify as an impaired accepting class under section 1129(a)(8) of the Bankruptcy Code.

F. Subordinated Claims.

The allowance, classification, and treatment of all Allowed Claims and Allowed Interests and the respective distributions and treatments under the Plan take into account and conform to the relative priority and rights of the Claims and Interests in each Class in connection with any contractual, legal, and equitable subordination rights relating thereto, whether arising under general principles of equitable subordination, section 510(b) of the Bankruptcy Code, or otherwise. Pursuant to section 510 of the Bankruptcy Code, the Debtors or Wind Down Debtors reserve the right to re-classify any Allowed Claim (including the LBM L Bond Claims to the extent provided by Article IV.I hereof) or Allowed Interest in accordance with any contractual, legal, or equitable subordination relating thereto.

G. Presumed Acceptance of Plan.

If a Class contains Claims eligible to vote and no Holder of Claims eligible to vote in such Class votes to accept or reject the Plan, the Plan shall be presumed accepted by the Holders of such Claims in such Class. Classes 1, 2, 4(b), and 5 are Unimpaired under this Plan. Therefore, the Holders of Claims in such Classes are deemed to have accepted this Plan pursuant to section 1126(f) of the Bankruptcy Code and are not entitled to vote to accept or reject the Plan.

H. Presumed Rejection of Plan.

Classes 6 and 7 are Impaired, and the Holders of Claims or Interests in such Classes shall receive no distribution under the Plan on account of such Claims or Interests. Therefore, the Holders of Claims or Interests in such Classes are deemed to have rejected this Plan pursuant to section 1126(g) of the Bankruptcy Code and are not entitled to vote to accept or reject this Plan.

I. Acceptance by Impaired Classes of Claims.

Pursuant to section 1126(c) of the Bankruptcy Code and except as otherwise provided in section 1126(e) of the Bankruptcy Code, an Impaired Class of Claims has accepted this Plan if the Holders of at least two-thirds (2/3) in dollar amount and more than one-half (1/2) in number of the Allowed Claims in such Class actually voting have voted to accept this Plan.

J. Acceptance by Impaired Classes of Interests.

Pursuant to section 1126(d) of the Bankruptcy Code and except as otherwise provided in section 1126(e) of the Bankruptcy Code, an Impaired Class of Interests has accepted this Plan if the Holders of at least two-thirds (2/3) in dollar amount of the Allowed Interests in such Class actually voting have voted to accept this Plan.

K. Confirmation Pursuant to Sections 1129(a)(10) and 1129(b) of the Bankruptcy Code.

Section 1129(a)(10) of the Bankruptcy Code shall be satisfied for purposes of Confirmation by acceptance of this Plan by Classes 3 or 4(a). The Debtors request Confirmation of this Plan under section 1129(b) of the Bankruptcy Code with respect to any Impaired Class that does not accept this Plan pursuant to section 1126 of the Bankruptcy Code. The Debtors reserve the right to modify this Plan, subject to the Proponents' Consent Right, including the Plan Supplement, in order to satisfy the requirements of section 1129(b) of the Bankruptcy Code, if necessary.

L. Controversies Regarding Impairment.

If a controversy arises as to whether any Claims or Interests, or any Class of Claims or Interests, are Impaired, the Bankruptcy Court shall, after notice and a hearing, determine such controversy on or before the Confirmation Date.

**ARTICLE IV.
MEANS FOR IMPLEMENTATION OF THE PLAN**

A. Wind Down Trust.

1. Wind Down Trust Generally.

The Confirmation Order shall provide that, upon the occurrence of the Effective Date, the Wind Down Trust shall be deemed established in accordance with the Wind Down Trust Agreement and the Plan. On the Effective Date, the Wind Down Trust shall commence the taking of all necessary steps to wind down the business affairs of the Debtors.

The Wind Down Trust Assets shall be deemed disbursed by the Debtors and transferred to the Wind Down Trust on the Effective Date, the proceeds of which shall be distributed in accordance with the waterfall set forth in Article IV.H. The powers, authorities, responsibilities, and duties of the Wind Down Trust and the Wind Down Trustee are set forth in and shall be governed by this Plan and the Wind Down Trust Agreement. The Wind Down Trust Agreement, which shall be part of the Plan Supplement, shall be consistent with the Plan and shall contain provisions customary to trust agreements utilized in comparable circumstances, including, without limitation, any and all provisions necessary to ensure the continued treatment of the Wind Down Trust as a grantor trust. The Wind Down Trust Agreement may provide powers, duties, and authorities in addition to those explicitly stated herein, but only to the extent that such powers, duties, and authorities do not affect the status of the Wind Down Trust as a "liquidating trust" for United States federal income tax purposes or as an entity that can fall within the exception from registration in Section 7 of the 1940 Act for activities of companies that are merely incidental to their dissolution.

Notwithstanding anything to the contrary herein, the Wind Down Trust's sole purpose is to liquidate the Wind Down Trust Assets with a view towards maximizing the value of such assets for the benefit of New WDT Interest holders, and promptly distributing such liquidation proceeds (in accordance with the provisions of this Plan) to New WDT Interest holders. The Wind Down Trust will have no going concern operations and will not be permitted to continue or engage in the conduct of a trade or business or to make any investments (other than holding, on a temporary

basis (pending distribution to holders or use for payment of permitted expenses) certain short-term, high-quality cash equivalents (as set out in the Wind Down Trust Agreement); instead the Wind Down Trust's activities will be limited to those reasonably necessary to, and consistent with, the Wind Down Trust's liquidating purpose and reasonably necessary to conserve, protect, and/or maximize the value of the Wind Down Trust Assets and provide for the orderly liquidation thereof. The Wind Down Trust Agreement shall contain appropriate provisions for monetizing the Wind Down Trust Assets in an orderly fashion, subject to the Wind Down Trustee's reasonable business judgment. The Wind Down Trustee, on behalf of the Wind Down Trust, will have discretion to enter into, consummate, settle, or otherwise resolve any transaction or dispute with respect to each of the Wind Down Trust Assets that have an economic value of less than \$5 million (in the Wind Down Trustee's good faith determination) as of the date of the consummation, settlement, or resolution of such transaction or dispute. The Wind Down Trustee will submit all other matters to the Bankruptcy Court for approval after notice and an opportunity for a hearing.

The Wind Down Trust will have an initial term of three years, which, subject to applicable law, may be extended by the Wind Down Trustee Filing a motion with the Bankruptcy Court prior to the expiration of the existing term and obtaining Bankruptcy Court approval of an extension for up to two years per request (subject, in each instance, to reasonable due consideration being given to implications of tax law and other applicable law of the proposed extension of the term of the Wind Down Trust). The Wind Down Trustee and the Litigation Trustee will cooperate and confer to ensure that the Wind Down Trust does not terminate prior to the Litigation Trust.

2. Transfer of Assets Into the Wind Down Trust.

Except as otherwise provided in this Plan or the Confirmation Order, on the Effective Date, the Wind Down Trust Assets shall be deemed transferred to the Wind Down Trust by the Debtors, such assets shall vest in the Wind Down Trust on such date, to be administered by the Wind Down Trustee in accordance with this Plan and the Wind Down Trust Agreement, and the Debtors and their Estates shall have no further interest with respect to the Wind Down Trust Assets. The Wind Down Trust Assets will vest in the Wind Down Trust free and clear of all Liens, Claims, Interests, encumbrances, etc. The act of transferring the Wind Down Trust Assets, as authorized by this Plan, shall not be construed to destroy or limit any such assets or rights or be construed as a waiver of any right, and such rights may be asserted by the Wind Down Trustee as if the asset or right was still held by the relevant Debtor.

The Wind Down Trustee shall have the authority to create additional sub-trusts within (or other subsidiary Entities under) the Wind Down Trust, which may have a separate legal existence, but which shall be considered sub-trusts (or other subsidiary Entities under, as applicable) of the Wind Down Trust.

3. Wind Down Trustee.

The Wind Down Trustee shall have the sole authority to make decisions and take action with respect to the Wind Down Trust in accordance with the terms of this Plan and the Wind Down Trust Agreement. The Wind Down Trustee shall be the successor to and representative of the Estates of the Debtors within the meaning of section 1123(b)(3)(B) of the Bankruptcy Code. Following the Effective Date, the Wind Down Trust and the Wind Down Trustee shall be deemed

a party in interest with standing to appear in the Chapter 11 Cases and object to any pleading Filed thereafter; *provided, however*, such standing and right to object does not alter the respective rights or responsibilities of the Wind Down Trustee or the Litigation Trustee under the Plan, the Wind Down Trust Agreement, or the Litigation Trust Agreement, alter any governing approval standard under applicable law, or otherwise limit the ability of any party with standing to respond to pleadings Filed, or objections raised, by the Wind Down Trustee. The powers, rights, and responsibilities of the Wind Down Trustee shall be specified in this Plan and the Wind Down Trust Agreement, and shall include, within the confines of the stated purpose of the Wind Down Trust, taking all appropriate actions to maximize the value of and monetize the Wind Down Trust Assets for the benefit of stakeholders, whether by accepting, preserving, receiving, collecting, administering, selling, liquidating, or transferring, as applicable, the Wind Down Trust Assets. All determinations with respect to the monetization of the Wind Down Trust Assets, including the Wind Down Trust's interests in Beneficient and FOXO, will be subject to the reasonable business judgment of the Wind Down Trustee, subject to compliance with any applicable lock-up agreement or securities law requirements and subject to the requirement that the Wind Down Trustee seek and obtain Bankruptcy Court approval of any transaction with an economic value of \$5 million or more, as set forth herein.

For the avoidance of doubt, the Wind Down Trustee may conduct sales or liquidations of Wind Down Trust Assets on any terms it deems reasonable, without further order of the Bankruptcy Court (except as provided herein). The Wind Down Trustee may also abandon any Wind Down Trust Assets that the Wind Down Trustee determines in its reasonable discretion to be of *de minimis* value or burdensome to the Wind Down Trust.

The Wind Down Trustee shall use the Wind Down Amount (and any subsequent monetization proceeds from the Wind Down Trust) to fund all expenses related to its duties under this Plan. The Wind Down Trustee, on behalf of the Wind Down Trust, may employ, without further order of the Bankruptcy Court, professionals (including professionals previously engaged in the Chapter 11 Cases), employees, or other independent contractors to assist in carrying out its duties this Plan, including the Wind Down Trust Agreement, and may compensate and reimburse the expenses of these professionals, employees, or other independent contractors based upon the nature of the work performed by such parties without further order of the Bankruptcy Court, subject to any limitations and procedures established by the Wind Down Trust Agreement.

4. Reports to Be Filed by the Wind Down Trust.

Following the Effective Date, and during the existence of the Wind Down Trust, the Wind Down Trust shall File with the Bankruptcy Court (and provide to any other party entitled to receive any such report pursuant to the Wind Down Trust Agreement), within 90 days after the end of each calendar year during the term of the Wind Down Trust, and within 45 days after the end of each calendar quarter during the term of the Wind Down Trust (other than the fourth quarter) and as soon as practicable upon termination of the Wind Down Trust, the Wind Down Trustee shall make available on its website, a written report including: (a) financial statements of the Wind Down Trust for such period, and, if the end of a calendar year, an unaudited report (which may be prepared by an independent certified public accountant employed by the Wind Down Trustee) reflecting the result of such agreed-upon procedures relating to the administration of the Wind Down Trust as proposed by the Wind Down Trustee; (b) a summary description of any action

taken by the Wind Down Trust which, in the judgment of the Wind Down Trustee, materially affects the Wind Down Trust; (c) a description of the progress of liquidating the Wind Down Trust Assets and making distributions to the holders of the New WDT Interests, which description shall include a written report detailing, among other things, the status of the equity interests in Beneficient and FOXO that are held by the Wind Down Trust, the status of Portfolio Co., the status of the Litigation Trust, the proceeds recovered as of the relevant date with respect to assets of the Wind Down Trust or any of the foregoing, and the distributions made by the Wind Down Trust as of the relevant date; and (d) any other material or significant information relating to the Wind Down Trust Assets and the administration of the Wind Down Trust deemed appropriate to be disclosed by the Wind Down Trustee. In addition, the Wind Down Trust shall provide unaudited financial statements to each holder of the New WDT Interests on a quarterly basis (which may be quarterly operating reports Filed with the Bankruptcy Court). The Wind Down Trustee may post any such report on a website maintained by or on behalf of the Wind Down Trustee and electronically File it with the Bankruptcy Court in lieu of actual notice to each holder of New WDT Interests (unless required by law).

Notwithstanding the foregoing, so long as the Wind Down Trust files periodic reports with the SEC pursuant to Section 13(a) or Section 15(d) of the Securities Exchange Act, the Wind Down Trustee shall be deemed to have satisfied its obligations set forth in the preceding paragraph by filing such periodic reports with the SEC, posting a copy of such reports on a website maintained by or on behalf of the Wind Down Trustee, and Filing a copy of such reports with the Bankruptcy Court.

5. 1940 Act Matters.

The implementation of this Plan and the Wind Down Transactions, *inter alia*, via the creation and administration of the Wind Down Trust, the Portfolio Co. and the Litigation Trust, is intended to enable the Wind Down Trust and the Debtors to fall within an exception to registration for companies that are dissolving, in accordance with Section 7 of the 1940 Act and the SEC staff's guidance regarding the same (the "Liquidating Company Exception"). In the event that the Wind Down Trustee determines in its sole and absolute discretion at any time that, notwithstanding such remedial actions undertaken or to be undertaken by the Wind Down Trust and/or the Debtors pursuant to the provisions of this Plan, the Wind Down Trust and the Debtors nonetheless are or will be unable to comply with or otherwise qualify for the Liquidating Company Exception or any other exception to or an exemption from registering under the 1940 Act, the Wind Down Trustee shall have the sole discretion and authority to develop another strategy to comply with or otherwise qualify under an exception to or exemption from such requirements of the 1940 Act. If it becomes necessary for 1940 Act compliance purposes to change the organization, operations and/or activities of the Wind Down Trust, the Wind Down Trustee will attempt to do so in a way to preserve the economic benefits of ownership of Wind Down Trust to the maximum extent possible.

B. U.S. Federal Income Tax Treatment and Reporting.

The Wind Down Trust is intended to qualify as a "grantor trust" as governed by sections 671 through section 679 of the Internal Revenue Code for U.S. federal income tax purposes with the New WDT Interest holders treated as grantors and owners of the Wind Down Trust. For all U.S. federal and applicable state and local income tax purposes, all parties (including,

without limitation, the Debtors, the Wind Down Trustee and the New WDT Interest holders) shall treat the Wind Down Trust, other than any portion thereof in respect of which a “disputed ownership fund” election has been made, as a liquidating trust under Treasury Regulation Section 301.7701-4 of which the New WDT Interest holders are the grantors and owners. Accordingly, for federal income tax purposes, it is intended that the New WDT Interest holders be treated as if they had received a transfer from the Debtors of an undivided interest in the Wind Down Trust Assets (to the extent of the value of their respective share in the applicable Assets) and then contributed such interests to the Wind Down Trust, and the New WDT Interest holders will be treated as the grantors and owners thereof. As soon as practicable after the Effective Date, the Wind Down Trustee shall make a good faith determination of the fair market value of the Wind Down Trust Assets as of the Effective Date. This valuation shall be used consistently by all parties (including the Debtors, the Wind Down Trustee and the New WDT Interest holders) for all U.S. federal income tax purposes.

The Wind Down Trust shall be established for the primary purpose of liquidating and distributing the assets transferred to it, in accordance with Treasury Regulation section 301.7701-4(d), with no objective to continue or engage in the conduct of a trade or business, except to the extent reasonably necessary to, and consistent with, the liquidating purpose of the Wind Down Trust. The Wind Down Trust shall not be deemed a successor-in-interest of the Debtors for any purpose other than as specifically set forth in this Plan or in the Wind Down Trust Agreement. The record holders of New WDT Interests shall be recorded and set forth in a register maintained by the Wind Down Trustee expressly for such purpose.

The Wind Down Trustee shall be responsible for filing all federal, state, and local tax returns for the Wind Down Trust and for the Debtors. The Wind Down Trustee shall be responsible for payment, out of the Wind Down Trust Assets, of any taxes imposed on the Wind Down Trust or the Wind Down Trust Assets. The Wind Down Trustee may request an expedited determination of taxes of the Wind Down Trust under section 505(b) of the Bankruptcy Code for all returns filed for, or on behalf of, the Wind Down Trust for all taxable periods through the dissolution of the Wind Down Trust.

The Wind Down Trust shall comply with all withholding and reporting requirements imposed by any federal, state, or local taxing authority, and all distributions made by the Wind Down Trust shall be subject to any such withholding and reporting requirements. The Wind Down Trustee shall be authorized to take any and all actions that may be necessary or appropriate to comply with such withholding and reporting requirements including, without limitation, requiring that, as a condition to the receipt of a distribution, the Holder of an Allowed Claim or Interest complete the appropriate IRS Form W-8 or IRS Form W-9. Notwithstanding any other provision of the Plan to the contrary, (1) each Holder of an Allowed Claim or Interest that is to receive a distribution pursuant to this Plan shall have the sole and exclusive responsibility for the satisfaction and payment of any tax obligations imposed on such Holder by any Governmental Unit, including income and other tax obligations, on account of such distribution (whether from the Debtors, the Wind Down Trust, or otherwise), and (2) no distribution shall be made to or on behalf of such Holder under the Plan unless and until such Holder has made arrangements satisfactory to the Wind Down Trustee to allow it to comply with its tax withholding and reporting requirements. Any property to be distributed by the Wind Down Trust shall, pending the implementation of such arrangements, be treated as an undeliverable distribution to be held by the Wind Down Trustee

until such time as the Wind Down Trustee is satisfied with the Holder's arrangements for any withholding tax obligations.

C. General Settlement of Claims and Interests.

As discussed further in the Disclosure Statement and as otherwise provided herein, pursuant to section 1123 of the Bankruptcy Code and Bankruptcy Rule 9019 and in consideration for the classification, distributions, releases, and other benefits provided under this Plan, upon the Effective Date, the provisions of this Plan shall constitute a good faith compromise and settlement of Claims and Interests and controversies resolved pursuant to the Plan. The Plan shall be deemed a motion to approve the good faith compromise and settlement of all such Claims, Interests, and controversies pursuant to Bankruptcy Rule 9019. Entry of the Confirmation Order shall constitute the Bankruptcy Court's approval of such compromise and settlement under section 1123 of the Bankruptcy Code and Bankruptcy Rule 9019, as well as a finding by the Bankruptcy Court that such settlement and compromise is fair, equitable, reasonable, and in the best interests of the Debtors and their Estates. Distributions made to Holders of Allowed Claims and Allowed Interests in any Class are intended to be and shall be final.

D. Wind Down Transactions.

On the Effective Date, the Wind Down Trustee will enter into such Wind Down Transactions as may be necessary or appropriate on each of the Debtors' or the Wind Down Debtors', as applicable, behalf to merge, dissolve, or otherwise terminate the corporate existence of each of the Debtors in accordance with the Wind Down Trust Agreement and the constituent documents of the Debtors without further order of the Bankruptcy Court; *provided*, that the Debtors and the Creditor Proponents may agree to dissolve the Debtors on a later date in order to promote efficiencies in the accrual of tax and other payment liabilities. The actions to effect the Wind Down Transactions may include: (1) the execution and delivery of appropriate agreements or other documents of transfer, merger, consolidation, disposition, liquidation, or dissolution containing terms that, among other things, are consistent with the terms of this Plan; (2) the execution and delivery of appropriate instruments of transfer, assignment, assumption, or delegation of any asset, property, right, liability, duty, or obligation on terms consistent with the terms of this Plan and that satisfy the requirements of applicable law; (3) the filing of appropriate certificates or articles of merger, consolidation, continuance, or dissolution, or similar instruments with the applicable governmental authorities; and (4) the taking of all other actions that the Wind Down Trustee determines, in its sole discretion, to be necessary or appropriate, including making other filings or recordings that may be required by applicable law in connection with the Wind Down Transactions.

On the Effective Date, subject in all respects (and after giving effect) to the treatment, distribution, and all other provisions of the Plan and the Confirmation Order, all property in each Estate, all Causes of Action, and any property acquired by any of the Debtors pursuant to this Plan shall vest in the Wind Down Debtors (and thereafter ultimately in the Wind Down Trust and/or the Litigation Trust, as applicable), free and clear of all Liens, Claims, charges, Causes of Action, or other encumbrances, except for those Liens, Claims, charges, or other encumbrances arising from or related to the Vida Exit Financing Facility. Each Debtor may be deemed dissolved in accordance with applicable law, without any further notice to or action, order, or approval of the

Bankruptcy Court or any other Entity. The Wind Down Trust shall be the issuer of the New WDT Interests as set forth herein.

On or before the Effective Date, the Policy Portfolio will be transferred free and clear of all Liens, Claims, charges, Causes of Action, or other encumbrances (except solely with respect to any such interests expressly granted in connection with the Vida Exit Financing Facility) to the fullest extent provided by the Bankruptcy Code to Portfolio Co., and the Policy Portfolio Equity Interests will be issued and transferred pursuant to the provisions of this Plan to the Wind Down Trust.

The Confirmation Order shall and shall be deemed to, pursuant to sections 363 and 1123 of the Bankruptcy Code, authorize, among other things, all actions as may be necessary or appropriate to effect any transaction described, contemplated, or necessary to effectuate this Plan. The Debtors, Wind Down Trust, Wind Down Trustee, Litigation Trust, and Litigation Trustee shall all use best efforts to cooperate with each other to ensure all necessary actions are taken as contemplated under this Plan.

E. Litigation Trust.

1. Litigation Trust Generally.

The Litigation Trust will be established on the Effective Date to retain and hold all Retained Causes of Action, the proceeds of which shall be deemed distributed to the Wind Down Trust for ultimate distribution by or at the direction of the Wind Down Trustee in accordance with the waterfall set forth in Article VI.C hereof. On the Effective Date, the Initial Litigation Trust Assets shall be deemed transferred to the Litigation Trust by the Wind Down Trust and will vest in the Litigation Trust free and clear of all Liens, Claims, interests, encumbrances, etc., with all reversionary and beneficial interests in the Litigation Trust to be held by the Wind Down Trust, subject to the waterfall set forth in Article VI.C hereof. The sole beneficiary of the Litigation Trust will be the Wind Down Trust (or the Wind Down Trustee on behalf of the Wind Down Trust, to the extent provided by applicable law), and all proceeds of the Litigation Trust distributed to the Wind Down Trust on account of such reversionary interest shall be for the sole purpose of distributions to the holders of the New WDT Interests issued by the Wind Down Trust; *provided, however*, such proceeds may be otherwise retained and used by the Wind Down Trust only with the consent of the Litigation Trustee or by order of the Bankruptcy Court. The act of transferring the Initial Litigation Trust Assets, as authorized by this Plan, shall not be construed to destroy or limit any such assets or rights or be construed as a waiver of any right, and such rights may be asserted by the Litigation Trust as if the asset or right was still held by the relevant Debtor. Notwithstanding anything to the contrary herein, the Litigation Trust may abandon to creditors or otherwise not accept any Retained Causes of Action that the Litigation Trustee believes, in good faith, have no value to the Litigation Trust; *provided*, that the Litigation Trust Agreement shall provide for the assignment by creditors to the Litigation Trust of any such Retained Causes of Action so abandoned to creditors.

For the avoidance of doubt, the Litigation Trustee, on behalf of the Litigation Trust, shall step into the shoes of the Debtors as it relates to either communications that occurred prior to, or documents prepared before, April 20, 2022 with respect to Debtors' right to assert attorney-client

privilege or any other privilege or immunity Debtor possesses, if any, and the Litigation Trustee shall be entitled to preserve, assert, access, or waive such privilege or immunity of the Debtors as it relates to such documents or communications. On the Effective Date, the Litigation Trustee shall have the power, right and responsibility to access or take possession of all books, files and records of the Debtors or Wind Down Debtors, as applicable, for purposes of carrying out the purpose of the Litigation Trust. At any time after the Effective Date, upon reasonable request of the Litigation Trustee, the Wind Down Trustee shall provide the Litigation Trustee with any of the Debtors' or the Wind Down Debtors' books, records, and files in the Wind Down Trust's or Wind Down Trustee's possession, custody, or control, and the Wind Down Trustee may, in good faith, provide such privileged information of the Debtors as is in the Wind Down Trustee's possession that relates to the evaluation and prosecution of the Retained Causes of Action; *provided*, that, notwithstanding the foregoing, the privilege of the Independent Directors, the DLP Independent Directors, and David F. Chavenson in his capacity as a former member of the Special Committee, in each case, is hereby recognized and shall remain in full force and effect and shall not be waived, nor shall any such privileged documents be turned over to any person or Entity without the consent of all Independent Directors or all DLP Independent Directors, as applicable. For the avoidance of doubt, neither the Independent Directors nor the DLP Independent Directors may waive Mr. Chavenson's personal privilege. The Wind Down Trustee shall use commercially reasonable efforts to assist the Litigation Trustee by providing additional information based on the books, files, and records in the Wind Down Trust's possession, provided that any such request for assistance is reasonable. Following the Effective Date, the Litigation Trust and the Litigation Trustee shall be deemed a party in interest with standing to appear in the Chapter 11 Cases and object to any pleadings Filed thereafter; *provided, however*, such standing and right to object does not alter the respective rights or responsibilities of the Litigation Trustee or the Wind Down Trustee under the Plan, the Wind Down Trust Agreement, or the Litigation Trust Agreement, alter any governing approval standard under applicable law, or otherwise limit the ability of any party with standing to respond to pleadings Filed, or objections raised, by the Litigation Trustee.

2. Litigation Trustee.

The Litigation Trustee shall be an independent, third-party fiduciary selected by the Bondholder Committee and identified in the Plan Supplement, and shall be compensated at market rates; *provided*, that, for the avoidance of doubt, the Litigation Trustee shall have no affiliation with any Bondholder Committee member and must not own any Public L Bonds, New WDT Interests, or other Interests in or Securities issued by any of the Debtors. The Litigation Trustee shall have the sole authority to make decisions and take action with respect to the Initial Litigation Trust Assets, the Retained Causes of Action, and the Litigation Trust Reconciliation Claims, and shall have a duty to maximize the value of the assets of the Litigation Trust in accordance with the Litigation Trust Agreement. The Litigation Trustee shall confer with the Wind Down Trustee with respect to the commencement of any litigation in respect of such assets, provided that the ultimate decision with respect to whether to commence any litigation shall be in the sole discretion of the Litigation Trustee. For the avoidance of doubt, in exercising such sole discretion, the Litigation Trustee shall consider and may take such actions in connection with the exercise of such sole discretion that promote the greatest recovery to the holders of the New WDT Interests. The Litigation Trustee shall seek Bankruptcy Court approval, after notice and an opportunity for a hearing, of (a) any settlements with respect to the Retained Causes of Action, and (b) any other transaction with respect to any assets of the Litigation Trust, in each case, that has an economic

value of \$5 million or more (in the Litigation Trustee's good faith determination) as of the date of such transaction.

The Litigation Trustee shall use the Initial Litigation Trust Funding Amount to fund all expenses related to its duties under this Plan and the Litigation Trust Agreement. Thereafter, the Litigation Trust and the Litigation Trustee may use proceeds from monetizing the Retained Causes of Action to fund the reasonable and customary out-of-pocket expenses incurred by the Litigation Trust and Litigation Trustee. Beginning on the Effective Date, the Litigation Trustee shall have customary powers, including the power to employ (without further order of the Bankruptcy Court) professionals (including professionals previously engaged in the Chapter 11 Cases), employees, or other independent contractors to assist in carrying out its duties under this Plan, including the Litigation Trust Agreement, and may compensate and reimburse the expenses of these professionals, employees, or other independent contractors based upon the nature of the work performed by such parties without further order of the Bankruptcy Court, subject to any limitations and procedures established by the Litigation Trust Agreement.

3. Reports to Be Filed by the Litigation Trust.

Following the Effective Date, and unless otherwise ordered by the Bankruptcy Court, and during the existence of the Litigation Trust, the Litigation Trust shall File with the Bankruptcy Court (and provide to any other party entitled to receive any such report pursuant to the Litigation Trust Agreement), within 90 days after the end of each calendar year during the term of the Litigation Trust, and within 45 days after the end of each calendar quarter during the term of the Litigation Trust (other than the fourth quarter), a quarterly report regarding the administration of property subject to its ownership and control pursuant to this Plan, receipts, distributions made by it, an update regarding the status of the Retained Causes of Action being prosecuted by the Litigation Trust, and a summary of all major activities during the period.

4. Termination of the Litigation Trust.

The initial term of the Litigation Trust shall be the lesser of: (a) three years; (b) the date all holders of New Series A1 WDT Interests and New Series A2 WDT Interests receive the full amount to which they are entitled to pursuant to this Plan; and (c) the date that all Retained Causes of Action have been fully resolved, as reasonably determined by the Litigation Trustee in its sole determination; *provided, however*, that, subject to applicable law, the Litigation Trustee may extend the term of the Litigation Trust solely in the event termination would otherwise occur under subsection (a) of this paragraph by Filing a motion with the Bankruptcy Court prior to the expiration of the initial term and obtaining court approval of such extension, with a maximum extension of two (2) years per request (subject, in each instance, to reasonable consideration being given to implications of tax law and other applicable law of a proposed extension of the term of the Litigation Trust). The Wind Down Trustee and the Litigation Trustee will cooperate and confer to ensure that the Wind Down Trust does not terminate prior to the Litigation Trust. For the avoidance of doubt, no later than the termination of the Litigation Trust, the Litigation Trustee shall transfer all of the Litigation Trust's assets, including any remaining Retained Causes of Action and net proceeds realized therefrom, to the Wind Down Trust. Notwithstanding the foregoing, and for the avoidance of doubt, nothing in this Plan (or the Plan Supplement, as applicable) shall prohibit the Litigation Trustee from making interim transfers of Cash realized by

the Litigation Trust to the Wind Down Trust for distribution to holders of New WDT Interests in accordance with this Plan.

F. Sources of Plan Consideration.

1. Vida DIP Financing Facility and Vida Exit Financing Facility.

On the Effective Date, the Debtors (or the Wind Down Debtors, as applicable) shall obtain the Vida Exit Financing Facility from an affiliate of Vida, the terms of which will be set forth in the Vida Exit Financing Facility Documents. The proceeds from the Vida Exit Financing Facility shall be used to refinance the Vida DIP Financing Facility. Confirmation of this Plan shall be deemed approval of the Vida Exit Financing Facility and the Vida Exit Financing Facility Documents, as applicable, and all transactions contemplated thereby, and all actions to be taken, undertakings to be made, and obligations to be incurred by the Portfolio Co. in connection therewith, including the payment of all fees, indemnities, expenses, and other payments provided for therein and authorization of the Portfolio Co. to enter into and execute the Vida Exit Financing Facility Documents and such other documents as may be required to effectuate the treatment afforded by the Vida Exit Financing Facility. The proceeds from the Vida DIP Financing Facility and Vida Exit Financing Facility, as applicable, shall be used to fund, among other things, the Portfolio Proceeds Amount, the Initial Litigation Trust Funding Amount, and the Wind Down Amount. For the avoidance of doubt, PJT shall not earn an additional Capital Raising Fee on account of the Vida Exit Facility Financing.

On the Effective Date, all of the Liens and security interests in respect of the assets of Portfolio Co. to be granted in accordance with the Vida Exit Financing Facility Documents: (a) shall be deemed to be granted; (b) shall be legal, binding, and enforceable Liens on, and security interests in, the collateral granted thereunder in accordance with the terms of the Vida Exit Financing Facility Documents; (c) shall be deemed automatically perfected, subject only to such Liens and security interests as may be permitted under the Vida Exit Financing Facility Documents; and (d) shall not be subject to recharacterization or equitable subordination for any purposes whatsoever and shall not constitute preferential transfers or fraudulent conveyances under the Bankruptcy Code or any applicable non-bankruptcy law. The Wind Down Debtors shall be authorized to make all filings and recordings, and to obtain all governmental approvals and consents necessary to establish and perfect all Liens and security interests under the Vida Exit Financing Facility Documents under the provisions of the applicable state, federal, or other law that would be applicable in the absence of this Plan and the Confirmation Order (it being understood that perfection shall occur automatically by virtue of the Confirmation Order and any such filings, recordings, approvals, and consents shall not be required to perfect such Liens and security interests).

2. New WDT Interests.

On the Effective Date, the Wind Down Trust shall issue the New WDT Interests directly or indirectly to Holders of Claims and Interests to the extent provided in this Plan as follows:

- (a) New Series A1 WDT Interests: The Wind Down Trust shall issue the New Series A1 WDT Interests in an amount equal to the outstanding amount of

the Allowed Class 3 Bond Claims (less any LBM Subordinated Claims) after taking into consideration the Cash payment(s) made on account of such Claims on the Effective Date in connection with Article III.B.3 of this Plan. The New Series A1 WDT Interests shall be satisfied, redeemed, and cancelled in full in accordance with the terms and provisions of the New WDT Documents prior to any distributions on account of any subsequent series of New WDT Interests. Any New Series A1 WDT Interests, if any, issued to the Indenture Trustee on account of any outstanding Indenture Fee and Expense Claims shall be expressly senior in all respects to any New Series A1 WDT Interests issued to other Holders on account of their respective Allowed Class 3 Bond Claims.

- (b) New Series A2 WDT Interests: The Wind Down Trust shall issue the New Series A2 WDT Interests in an amount equal to the aggregate amount of Allowed LBM Subordinated Claims in Class 3. The New Series A2 WDT Interests shall be satisfied, redeemed, and cancelled in full in accordance with the terms and provisions of the New WDT Documents prior to any distributions on account of any subsequent series of New WDT Interests. The New Series A2 WDT Interests shall not receive any distributions prior to the satisfaction, redemption, and cancellation of the New Series A1 WDT Interests
- (c) New Series B WDT Interests: The Wind Down Trust shall issue the New Series B WDT Interests in an amount equal to the aggregate amount of Class 4(a) Allowed General Unsecured Claims. The New Series B WDT Interests shall be satisfied, redeemed, and cancelled in full in accordance with the terms and provisions of the New WDT Documents prior to any distributions on account of any subsequent series of New WDT Interests. The New Series B WDT Interests shall not receive any distributions prior to the satisfaction, redemption, and cancellation of the New Series A1 WDT Interests and the New Series A2 WDT Interests.
- (d) New Series C WDT Interests: The Wind Down Trust shall issue New Series C WDT Interests in an amount equal to the aggregate amount of Allowed Class 8 Series 1 Preferred Interests (based on each Series 1 Preferred Interest having an initial stated value of \$1,000.00 per share). The New Series C WDT Interests shall receive distributions on a *pari passu* basis with the New Series D WDT Interests, and the New Series C WDT Interests shall be satisfied, redeemed, and cancelled in full in accordance with the terms and provisions of the New WDT Documents prior to any distributions on account of the New Series E WDT Interests. The New Series C WDT Interests shall not receive any distributions prior to the satisfaction, redemption, and cancellation of the New Series A1 WDT Interests, the New Series A2 WDT Interests, and the New Series B WDT Interests.
- (e) New Series D WDT Interests: The Wind Down Trust shall issue the New Series D WDT Interests in an amount equal to the aggregate amount of

Allowed Class 9 Series 2 Preferred Interests (based on each Series 2 Preferred Interest having an initial stated value of \$1,000.00 per share). The New Series D WDT Interests shall receive distributions on a *pari passu* basis with the New Series C WDT Interests, and the New Series D WDT Interests shall be satisfied, redeemed, and cancelled in full in accordance with the terms and provisions of the New WDT Documents prior to any distributions on account of the New Series E WDT Interests. The New Series D WDT Interests shall not receive any distributions prior to the satisfaction, redemption and cancellation of the New Series A1 WDT Interests, the New Series A2 WDT Interests, and the New Series B WDT Interests.

- (f) New Series E WDT Interests: The Wind Down Trust shall issue the New Series E WDT Interests in a number equal to the aggregate number of Allowed Class 10 Common Stock. Holders of New Series E WDT Interests shall receive distributions as authorized by the Wind Down Trustee; *provided*, that (a) holders of New Series E WDT Interests shall not be entitled to receive any distributions until all other series of New WDT Interests have been satisfied, cancelled, and redeemed in accordance with the terms and provisions of the New WDT Documents, and (b) nothing herein requires the Wind Down Trustee to authorize any distributions to holders of New Series E WDT Interests.

The issuance of the New WDT Interests shall be authorized without the need for any further corporate action and without any further action by any party. The terms of the New WDT Interests shall be governed by the New WDT Documents, the terms of which shall be set forth in the Plan Supplement.

All of the New WDT Interests issued pursuant to this Plan shall be duly authorized, validly issued, fully paid, and non-assessable. Each distribution and issuance referred to in Article III hereof shall be governed by the terms and conditions set forth in this Plan applicable to such distribution or issuance, and by the terms and conditions relating to such distribution or issuance, which terms and conditions shall bind each Entity receiving such distribution or issuance.

G. Redemption of New WDT Interests.

Each Cash distribution from or at the direction of the Wind Down Trustee on behalf of the Wind Down Trust (including any Cash distributions consisting of any proceeds realized from the prosecution and/or settlement of the Retained Causes of Action by the Litigation Trust) on account of any New WDT Interests shall be deemed to constitute the redemption, satisfaction, and cancellation of such New WDT Interests in an amount equal to such Cash distribution. Cash recoveries from the Debtors' Estates, including the Wind Down Trust, or the Litigation Trust shall be deemed applied on a dollar-for-dollar basis as a redemption of, and in reduction of, the amount of such New WDT Interests.

Holders of the New WDT Interests cannot recover more than the full amounts owed on account of such New WDT Interests unless such recovery is: (1) permissible under applicable

law; and (2) from third-party sources other than the Debtors, the Wind Down Trust, or the Litigation Trust, as provided for under this Plan.

H. Priority of Cash Distributions to Holders of New WDT Interests.

The Wind Down Trustee shall make an initial Cash distribution to holders of New WDT Interests consisting of the Net Cash Proceeds, if any, within 60 days after the Effective Date, and on a semi-annual basis thereafter to the extent of any Net Cash Proceeds; *provided*, that the Wind Down Trustee may, in its sole discretion, make additional special distributions to the extent of any Net Cash Proceeds available; *provided, further*, that, in each instance, no distribution shall be required unless the Net Cash Proceeds then held by the Wind Down Trustee is equal to or greater than the Minimum Distribution Amount.

Any Cash distributions, including any distributions consisting of the Net Cash Proceeds realized from the monetization of the Wind Down Trust Assets, including the interests in Beneficial or FOXO, made by the Wind Down Trust to holders of New WDT Interests, after establishment of appropriate reserves for payment of Wind Down Trust expenses to the extent provided in the Wind Down Budget or the Wind Down Trust Agreement (or approved by separate order of the Bankruptcy Court), shall be distributed in the following order of priority (with no distributions to any junior class until all payments are made to senior classes in full):

1. the New Series A1 WDT Interests (if any) issued to the Indenture Trustee in connection with the Indenture Fee and Expense Claims in Class 3, up to the outstanding amount of such Claims;
2. all other New Series A1 WDT Interests, up to the Allowed outstanding prepetition amount of Allowed Bondholder Claims in Class 3;
3. the New Series A2 WDT Interests, up to the Allowed outstanding prepetition amount of Allowed LBM Subordinated Claims in Class 3;
4. the New Series A1 WDT Interests and the New Series A2 WDT Interests, up to the amount of interest accrued on such New Series A1 WDT Interests and New Series A2 WDT Interests, which interest shall accrue under the New WDT Documents from April 20, 2022 calculated at a 9% per annum interest rate;
5. the New Series B WDT Interests, up to the Allowed prepetition outstanding amount of Class 4(a) Allowed General Unsecured Claims;
6. the New Series B WDT Interests, up to the Allowed postpetition balance of Class 4(a) Allowed General Unsecured Claims, comprised of interest on the Allowed prepetition amount of such Claims starting from April 20, 2022 calculated at the Federal Judgment Rate;
7. the New Series C WDT Interests and the New Series D WDT Interests, on a pro rata *pari passu* basis, per liquidation rights under the New WDT Documents and applicable law, up to the Allowed aggregate outstanding amount of the Class 8 Series 1 Preferred Interests and Class 9 Series 2 Preferred Interests (based on each

Series 1 Preferred Interest and each Series 2 Preferred Interest having an initial stated value of \$1,000.00 per share); and

8. the New Series E WDT Interests.

I. LBM Settlement.

Unless LBM withdraws from the LBM Settlement as provided in the following paragraphs of this Article IV.I, on the Effective Date, the LBM L Bond Claims shall be: (1) Allowed in full with the LBM Subordinated Claims classified as Allowed Class 3 Bond Claims to be treated as provided in Article III.B.3.(b).(iii) of this Plan, and the remainder of the LBM L Bond Claims as Allowed Bondholder Claims in Class 3 to be treated as provided in Article III.B.3.(b).(i) and (ii) of this Plan; and (2) the LBM Released Claims shall be fully and finally released against all of the LBM Released Parties.

In the event that the Debtors reach a settlement with Beneficient, LBM shall have the right to withdraw from the agreements with respect to the allowance and treatment of the LBM L Bond Claims, and the right to releases, each as described and provided in the preceding paragraph by Filing a written notice on the docket within three Business Days of a motion to approve such Beneficient settlement being Filed on the docket. In event of such a timely-Filed withdrawal: (a) all agreements memorialized above shall be deemed withdrawn, including, but not limited to, all subordination agreements and all Claim allowances; (b) all claims, offsets, credits, objections and challenges of any kind to claims proposed to be settled above are reinstated in their entirety and shall be transferred to the Litigation Trust on the Effective Date as Litigation Trust Reconciliation Claims; and (c) the LBM L Bond Claims will be deemed Disputed Class 3 Claims without further action, Filing, or other request by the Debtors or the Bondholder Committee until the Claim Objection Bar Date at which time the LBM L Bond Claims shall be Allowed; *provided*, that such LBM L Bond Claims shall be considered Allowed only if and to the extent that no objection or other challenge in respect of the LBM L Bond Claims has been Filed on or prior to the Claim Objection Bar Date or such timely objection or other challenge has been Filed and the Claim thereafter has been Allowed by a Final Order. In any case, the LBM L Bond Claims shall be fully Allowed for voting purposes, and LBM agrees to and shall support and shall be deemed to accept this Plan on account of the LBM L Bond Claims and be a Creditor Proponent consistent with the Mediation Agreement (it being understood that any settlement with Beneficient shall be set forth in an order approving any such settlement under Bankruptcy Rule 9019 and that LBM's only rights with respect to a settlement with Beneficient are (i) withdrawing from the settlement set forth in this Article IV.I and/or (ii) objecting to such settlement with Beneficient).

In the event of such a withdrawal and subject to the timely Filing of an objection or other challenge to the LBM L Bond Claims: (i) the New Series A1 WDT Interests shall not be issued on account of any portion of the LBM L Bond Claims on the Effective Date; (ii) pending the resolution of such timely-Filed disputes, the Wind Down Trustee shall not make any distributions of any kind on account of the LBM L Bond Claims, but shall maintain appropriate reserves for the LBM L Bond Claims in any distribution on account of New Series A1 WDT Interests made during that period, in a manner the Wind Down Trustee solely determines is reasonable; (iii) no New Series A2 WDT Interests shall be issued on the Effective Date; *provided, however*, that prior to the Allowance (if any) of the LBM L Bond Claims, such class of New WDT Interests, as

applicable, shall not be deemed vacant; and (iv) upon the final resolution of any timely-Filed objection or other challenge of any kind through the entry of a Final Order of the Bankruptcy Court, the Wind Down Trustee shall cause to be issued or cancelled, as applicable, the New Series A1 WDT Interests and New Series A2 WDT Interests (as necessary), or any other class of New WDT Interests, as appropriate, so that LBM receives the New Series A1 WDT Interests in the Allowed, non-subordinated amount of its LBM L Bond Claims, if any, and the New Series A2 WDT Interests in the subordinated amount, if any, of its Allowed Class 3 LBM Subordinated Claims, or any other class of New WDT Interests, as appropriate, as determined by such Final Order, and the Wind Down Trustee shall thereafter promptly distribute (or redistribute) any such maintained reserve amounts, as appropriate, consistent with the determination in such Final Order. Notwithstanding any other provision of this Plan to the contrary: (x) the Debtors or the Wind Down Trustee, as the case may be, may modify the Plan to provide for treatment of the LBM L Bond Claims consistent with the determination in any such Final Order in subsection (iv) above; and (y) any conflict between the provisions of this subsection and any other provision of this Plan shall be governed by the provisions of this subsection.

J. Exemption from Registration Requirements.

The Debtors intend that the Wind Down Trust will be organized in compliance with applicable law such that the New WDT Interests will not be deemed to be or treated as securities under applicable law. As a result, the Debtors do not believe that registration under the Securities Act and applicable state law in connection with the issuance and distribution of the New WDT Interests or an exemption from such registration requirements is required. However, to the extent that the New WDT Interests issued under this Plan are deemed securities, the issuance and distribution thereof would qualify for issuance without registration under the Securities Act or any similar federal, state, or local law pursuant to section 1145 of the Bankruptcy Code. To the extent that the issuance and distribution of the New WDT Interests issued under this Plan is completed pursuant to section 1145 of the Bankruptcy Code, such New WDT Interests would be exempt from, among other things, the registration requirements of Section 5 of the Securities Act and any other applicable U.S. state or local law requiring registration prior to the offering, issuance, distribution, or sale of securities. Pursuant to section 1145 of the Bankruptcy Code, any such New WDT Interests issued under this Plan: (1) would not be “restricted securities” as defined in Rule 144(a)(3) under the Securities Act; and (2) as a matter of federal securities law, would be freely tradable and transferrable under the federal securities laws by any holder thereof that (a) is not an “affiliate” of the Wind Down Trust, as defined in Rule 144(a)(1) under the Securities Act, (b) has not been such an “affiliate” within three months of such transfer, (c) has not acquired the New WDT Interests from an “affiliate” within one year of such transfer, and (d) is not an Entity that is an “underwriter” as defined in section 1145(b) of the Bankruptcy Code.

Notwithstanding the forgoing or anything to the contrary in this Plan, the New WDT Documents will provide that the New WDT Interests may not be transferred, sold, pledged or otherwise disposed of, or offered for sale, except for transfers by will, intestacy or operation of law. The Wind Down Trust will be organized in compliance with applicable law such that the New WDT Interests will not be treated as securities and under such facts the Debtors do not believe that registration under the Securities Act and applicable state law in connection with the issuance and distribution of the New WDT Interests or an exemption from such registration requirements would be required. The Wind Down Trustee will be permitted to determine in its sole discretion

to take such actions that are necessary or reasonably advisable (including, without limitation, completing a registration under the Securities Exchange Act) to modify or remove any contractual restrictions on transferability of the New WDT Interests, with any such determination by the Wind Down Trustee, and all costs associated therewith, to be deemed a determination with respect to the monetization of the Wind Down Trust Assets subject to Bankruptcy Court approval to the extent provided pursuant to Article IV.A.3 hereof and to be evaluated solely under a reasonable business judgment standard.

To the extent that the New WDT Interests are rendered transferable as described in the preceding paragraph, DTC shall be required to accept and conclusively rely upon this Plan or the Confirmation Order in lieu of a legal opinion regarding whether such securities are exempt from registration and/or eligible for DTC book-entry delivery, settlement, and depository services. Notwithstanding anything to the contrary in this Plan, no legal opinion regarding the offering, issuance, and distribution of any securities contemplated by this Plan, including, for the avoidance of doubt, whether the New WDT Interests are exempt from registration and/or eligible for DTC book-entry delivery, settlement, and depository services shall be required.

K. Section 1146(a) Exemption.

To the fullest extent permitted by section 1146(a) of the Bankruptcy Code, any transfers (whether from a Debtor to the Wind Down Trust, the Litigation Trust, or to any other from any other party, as the case may be) of property under this Plan or pursuant to: (1) the issuance, Reinstatement, distribution, transfer, or exchange of any debt, equity interest, or other interest in the Debtors or the Wind Down Trust; (2) the transactions, including the Wind Down Transactions, described herein; (3) the creation, modification, consolidation, termination, refinancing, and/or recording of any mortgage, deed of trust, or other security interest, or the securing of additional indebtedness by such other means; (4) the making, assignment, or recording or any lease or sublease; (5) the grant of collateral as security for any or all of the Debtors or Wind Down Debtors' obligations under or in connection with the Vida Exit Financing Facility; or (6) the making, delivery, or recording of any deed or other instrument of transfer under, in furtherance of, or in connection with, this Plan, including any deeds, bills of sale, assignments, or other instrument of transfer executed in connection with any transaction arising out of, contemplated by, or in any way related to this Plan, shall not be subject to any document recording tax, stamp tax, conveyance fee, intangibles or similar tax, mortgage tax, stamp act, real estate transfer tax, personal property transfer tax, mortgage recording tax, Uniform Commercial Code filing or recording fee, regulatory filing or recording fee, or other similar tax or governmental assessment, and upon entry of the Confirmation Order, the appropriate state or local governmental officials or agents shall forego the collection of any such tax, recordation fee or governmental assessment and accept for filing and recordation of any of the foregoing instruments or other documents without the payment of any such tax, recordation fee, or governmental assessment. All filing or recording officers (or any other person with authority over any of the foregoing), wherever located and by whomever appointed, shall comply with the requirements of section 1146(c) of the Bankruptcy Code, shall forego the collection of any such tax, recordation fee or governmental assessment, and shall accept for filing and recordation any of the foregoing instruments or other documents without the payment of any such tax, recordation fee, or governmental assessment.

L. Cancellation of Securities and Agreements.

On the Effective Date, except to the extent otherwise provided in the Plan, the Confirmation Order, or any agreement, instrument or other document entered into in connection with the Plan, all prepetition credit agreements, security agreements, intercreditor agreements, notes, instruments, Certificates, and other documents evidencing, or in any way related to, Claims or Interests (including the Indenture Documents) shall be deemed cancelled and surrendered without further action or approval of the Bankruptcy Court or any Holder of a Claim or Interest, and the obligations of the Debtors thereunder or in any way related thereto shall be released, settled, and compromised, and the Indenture Trustee, and its agents, successors and assigns shall each be automatically and fully released and discharged of and from all duties and obligations thereunder; *provided*, that, notwithstanding Confirmation or the occurrence of the Effective Date, any such prepetition credit agreement, security agreement, intercreditor agreement, or other document that governs the rights of the Holder of a Claim or Interest (including the Indenture Documents) shall continue in effect solely for purposes of: (1) enabling Holders of Allowed Claims and Allowed Interests to receive distributions under the Plan as provided herein; (2) governing the contractual rights and obligations among creditor parties (including, without limitation, indemnification, expense reimbursement, and distribution provisions); (3) allowing the Indenture Trustee to exercise its Indenture Trustee Charging Lien against distributions to Holders of Claims under the Indenture Documents, as applicable; (4) preserving all rights, remedies, indemnities, powers, and protections, including rights of enforcement, of the Indenture Trustee against any person or entity (including, without limitation, with respect to any indemnification or contribution from Holders of Bond Claims under the Indenture), other than the Debtors or the Wind Down Debtors (except as otherwise provided in this Plan) or any exculpations of the Indenture Trustee, to the extent that such rights, remedies, indemnities, powers, or protections exist pursuant to the terms of the Indenture Documents and applicable law; (5) permitting the Indenture Trustee to appear in the Chapter 11 Cases or in any proceeding in the Bankruptcy Court or any other court, including to enforce the obligations owed to it under this Plan and to enforce any obligations owed to Holders of Bond Claims under this Plan in accordance with the applicable Indenture Documents; and (6) permitting the Indenture Trustee to perform any functions that are necessary to effectuate the foregoing; *provided, further*, that, except to the extent otherwise provided in this Plan, the Confirmation Order, or any agreement, instrument or other document entered into in connection with this Plan, the survival of any prepetition credit agreements, security agreements, intercreditor agreements, rights, notes, instruments, Certificates, and other documents evidencing Claims or Interests shall not give rise to any Claims against the Debtors, the Wind Down Debtors, or the Wind Down Trustee or their respective officers, managers, directors, representatives, and agents for fees, expenses, or otherwise. As a condition precedent to receiving any distribution on account of its Allowed Class 3 Bond Claim, each Holder of an Allowed Class 3 Bond Claim shall be deemed to have surrendered its respective bonds and other documentation underlying its Class 3 Bond Claims, and all such surrendered bonds and other documentation shall be deemed to be cancelled pursuant to this section, except to the extent otherwise provided herein.

M. Corporate Action.

Upon the Effective Date, or as soon thereafter as is reasonably practicable, and without the need for any further corporate action or other action by Holders of Claims or Interests, all corporate actions contemplated under this Plan shall be deemed authorized and approved in all respects,

without the need for any approvals, authorizations, or consents, except for those expressly required pursuant to this Plan, or any further notice to or action, order, or approval of the Bankruptcy Court, including, as applicable: (1) selection and appointment of the Wind Down Trustee; (2) the creation of and vesting in the Wind Down Trust, including the adoption, execution, acknowledgement, delivery, recording, and/or filing (as applicable) of the Wind Down Trust Agreement; (3) the authorization, issuance, delivery, and distribution of the New WDT Interests issued pursuant to this Plan; (4) the execution of and entry into the Vida Exit Financing Facility Documents; (5) the creation of and vesting in the Litigation Trust; and (6) all other actions contemplated by this Plan (whether to occur before, on, or after the Effective Date).

Upon the Effective Date, all matters provided for in this Plan involving the corporate or company structure of the Debtors, the Wind Down Debtors, or the Wind Down Trust and any corporate or company action required by the Debtors or the Wind Down Trustee in connection with this Plan, including the transfer of the Policy Portfolio to Portfolio Co. and the issuance of the Policy Portfolio Equity Interests, shall be deemed to have occurred and shall be in effect, without any requirement or further action by the security holders, directors, managers, or officers of the Debtors, the Wind Down Debtors, or the Wind Down Trustee. On or prior to the Effective Date (as applicable), the appropriate officers of the Debtors, the Wind Down Trustee, or the Litigation Trustee (as applicable) shall be authorized and (as applicable) directed to issue, execute, and deliver the agreements, documents, securities, and instruments contemplated under this Plan (or necessary or desirable to effect the transactions contemplated under this Plan) in the name of and on behalf of the Wind Down Debtors, the Wind Down Trust, and/or the Litigation Trust including the New WDT Interests, the Wind Down Trust Agreement, the Litigation Trust Agreement, the Vida Exit Financing Facility Documents, and any and all other agreements, documents, securities, and instruments relating to the foregoing. The authorizations and approvals contemplated by this Article IV.M shall be effective notwithstanding any requirements under non-bankruptcy law.

N. Dissolution and Board of Directors.

As of the Effective Date, the term of the current members of the board of directors of the Debtors, including the Independent Directors and the DLP Independent Directors, shall expire, the Investigations Committee, the Special Committee and each conflicts committee at each DLP Entity shall cease to exist; *provided, that*, following the Effective Date, the Independent Directors and the DLP Independent Directors shall retain authority solely with respect to matters related to Accrued Professional Compensation Claims by Professionals acting at their authority and direction in accordance with the terms of the Plan. Any Causes of Action that have been commenced by the Investigations Committee, and are not released pursuant to Article VIII.C hereof, shall be included in the Retained Causes of Action and transferred to the Litigation Trust on the Effective Date. Notwithstanding any other language to the contrary herein, solely with respect to communications that occurred on or after April 20, 2022, each of the Independent Directors in their capacity as such, the DLP Independent Directors in their capacity as such, and David F. Chavenson in his capacity as a former member of the Special Committee, shall not have any of their respective privileged and confidential documents, communications or information transferred (or deemed transferred) to the Wind Down Debtors, the Wind Down Trustee, the Wind Down Trust, the Litigation Trust, the Litigation Trustee, any liquidation trust that may be formed or its trustee or board, or any related party of any of the foregoing Entities, or any other person or Entity,

without the prior written consent of the Independent Directors or the DLP Independent Directors, as applicable. For the avoidance of doubt, neither the Independent Directors nor the DLP Independent Directors may waive Mr. Chavenson's personal privilege.

As of the Effective Date, the Wind Down Trustee shall act as the Wind Down Debtors' sole officer, director, and manager, as applicable, with respect to the Wind Down Debtors' affairs, other than with respect to the Litigation Trust or Portfolio Co., as set forth herein. On the Effective Date, any remaining officers, managers, or managing members of any Debtor shall be dismissed without further action required on the part of any such Debtor or any other party.

O. Effectuating Documents; Further Transactions.

On and after the Effective Date, the Wind Down Trust and the Wind Down Trustee are authorized to and may issue, execute, deliver, file, or record such contracts, securities, instruments, releases, and other agreements or documents and take such actions as may be necessary to effectuate, implement, and further evidence the terms and conditions of the Plan and the New WDT Interests issued pursuant to this Plan, without the need for any approvals, authorizations, or consents, except for those expressly set forth in and required pursuant to this Plan. On and after the Effective Date, except as otherwise provided herein, the Wind Down Trust and the Litigation Trust, as applicable, may engage in activities as set forth herein and may use, acquire, or dispose of property and pursue, compromise, or settle any Claims, Interests, or Retained Causes of Action without supervision or approval by the Bankruptcy Court (except as otherwise provided herein) and free of any restrictions of the Bankruptcy Code or Bankruptcy Rules.

P. Vesting of Assets.

Except as otherwise provided herein, or in any agreement, instrument, or other document incorporated in this Plan, on the Effective Date, all property in each Debtor's Estate, all claims, rights, defenses, and Retained Causes of Action, and any property acquired by the Wind Down Trust, Litigation Trust, or Wind Down Debtors under or in connection with this Plan shall vest in the Wind Down Trust, Litigation Trust, or each of the Wind Down Debtors, as applicable, free and clear of all Liens, Claims, charges, or other encumbrances (except for those Liens, Claims, charges, or other encumbrances arising from or related to the Vida Exit Financing Facility), for subsequent or deemed transfer by each such party, pursuant to the provisions of this Plan.

Q. Preservation of Causes of Action.

In accordance with section 1123(b) of the Bankruptcy Code, the Litigation Trust shall retain and may enforce all rights to commence and pursue, as appropriate, any and all Causes of Action, whether arising before or after the applicable Petition Date, including without limitation any Causes of Action specifically enumerated in the schedule of Retained Causes of Action included in the Plan Supplement and the Litigation Trust's right to commence, prosecute, or settle such Causes of Action shall be preserved notwithstanding the occurrence of the Effective Date. For the avoidance of doubt, Causes of Action that are or were settled, released, waived, exculpated, or transferred pursuant to the Plan or any order of the Bankruptcy Court entered in these Chapter 11 Cases (as the same may be amended, modified, or supplemented from time to time by the Debtors), shall not constitute Retained Causes of Action.

The Litigation Trust may pursue such Retained Causes of Action, as appropriate and in accordance with the Litigation Trust Agreement. **No Entity may rely on the absence of a specific reference in this Plan, the Litigation Trust Agreement, the Plan Supplement, or the Disclosure Statement to any Cause of Action against it as any indication that the Debtors, the Wind Down Debtors, the Wind Down Trust, or the Litigation Trust, as applicable, will not pursue any and all available Causes of Action against it. The Debtors, the Wind Down Debtors, the Wind Down Trust, or the Litigation Trust, as applicable, expressly reserve all rights to prosecute any and all Causes of Action against any Entity, except as otherwise expressly provided in this Plan, including Article VIII of this Plan.** Unless any Causes of Action against an Entity is expressly waived, relinquished, exculpated, released, compromised, or settled in this Plan or a Bankruptcy Court order, the Wind Down Debtors expressly reserve all Causes of Action for later adjudication and, therefore, no preclusion doctrine, including the doctrines of res judicata, collateral estoppel, issue preclusion, claim preclusion, estoppel (judicial, equitable, or otherwise), or laches shall apply to such Causes of Action upon, after, or as a consequence of the Confirmation of this Plan.

The Litigation Trust reserves and shall retain such Causes of Action notwithstanding the rejection or repudiation of any Executory Contract or Unexpired Lease during the Chapter 11 Cases or pursuant to this Plan. In accordance with section 1123(b)(3) of the Bankruptcy Code, any Causes of Action that a Debtor may hold against any Entity shall be deemed transferred to and vest in the Litigation Trust except as otherwise expressly provided in this Plan. The Litigation Trust, through its authorized agents or representatives, shall retain and may exclusively enforce any and all Retained Causes of Action. The Litigation Trust shall have the exclusive right, authority, and discretion to determine and to initiate, file, prosecute, enforce, abandon, settle, compromise, release, withdraw, or litigate to judgement any such Causes of Action and to decline to do any of the foregoing without the consent or approval of any third party or further notice to or action, order, or approval of the Bankruptcy Court; *provided*, that the entry into any settlement of any Claim, Cause of Action, or other dispute with an economic value of \$5 million or more (in the Litigation Trustee's good faith determination) as of the date of the consummation, settlement, or resolution of such transaction or dispute shall require the approval of the Bankruptcy Court after notice and an opportunity for a hearing.

Notwithstanding anything contained herein to the contrary (including the Debtor Release described in Article VIII.C hereof), to the extent the Debtors are releasing or have previously released certain claims and Causes of Action against a party, including pursuant to this Plan or any Final Order of the Bankruptcy Court entered in these Chapter 11 Cases on or before the Effective Date, nothing in this Plan shall be construed to revive such released claims and Causes of Action against such party or be construed to impair or otherwise limit the releases provided thereunder.

R. Continuing Effectiveness of Final Orders.

Payment authorization granted to the Debtors under any prior Final Order entered by the Bankruptcy Court shall continue in effect after the Effective Date. Accordingly, the Debtors, the Wind Down Debtors, the Wind Down Trustee, and the Litigation Trustee, as applicable, may pay or otherwise satisfy any Claim to the extent permitted by, and subject to, the applicable Final Order without regard to the treatment that would otherwise be applicable to such Claim under this Plan.

S. D&O Liability Insurance Policies.

Notwithstanding anything in this Plan to the contrary, all of the Debtors' D&O Liability Insurance Policies and any agreements, documents, or instruments relating thereto, are treated as and deemed to be Executory Contracts under this Plan. On the Effective Date, pursuant to section 365(a) of the Bankruptcy Code, the Debtors shall be deemed to have assumed all D&O Liability Insurance Policies and any agreements, documents, and instruments related thereto (including tail coverage liability insurance). Entry of the Confirmation Order will constitute the Bankruptcy Court's approval of the Debtors' assumption of all such insurance policies, including the D&O Liability Insurance Policies. After the Effective Date, the Wind Down Debtors and the Litigation Trust, as applicable, shall not terminate or otherwise reduce, modify, or restrict in any way the coverage under any D&O Liability Insurance Policy (including such tail coverage liability insurance) in effect as of the Effective Date, including with respect to conduct occurring on or prior to April 20, 2022, and all members, managers, directors, and officers of the Debtors who served in such capacity at any time prior to the Effective Date of the Plan and who are covered by any such policy shall be entitled to the full benefits of any such policy for the full term of such policy regardless of whether such members, managers, directors, and/or officers remain in such positions after the Effective Date. Without limiting the generality of the other provisions of this Plan, and following such assumption, all right, title, and interest of the Debtors (and of the Wind Down Debtors and the Litigation Trust, as applicable) in and to any D&O Liability Insurance Policy (including any such tail coverage liability insurance) in effect as of the Effective Date covering claims relating to conduct occurring on or prior to April 20, 2022 shall be deemed assigned and fully transferred on the Effective Date to the Litigation Trust and shall constitute Initial Litigation Trust Assets for all purposes.

T. Payment of Certain Fees.

On the Effective Date, the Debtors or the Wind Down Debtors, as applicable, shall pay in full in Cash the Indenture Fee and Expense Claim incurred at any time prior to and through the Effective Date from the Portfolio Proceeds up to the amount: (1) agreed to by the Debtors, the Indenture Trustee, and the Creditor Proponents, without the need for the Indenture Trustee to File any Proof of Claim, request for payment of Administrative Claim, fee application, itemized time details, or any other pleading or document in the Chapter 11 Cases, and without reduction to recoveries on account of any of the Allowed Bond Claims; or (2) as determined by the Bankruptcy Court, in the event that the amount is not resolved pursuant to mediation. From and after the Effective Date, the Wind Down Debtors shall pay in full in Cash the Indenture Fee and Expense Claim incurred in connection with distributions, communications to Holders, responses to Holder inquiries, or the cancellation and discharge of the Indenture Documents, without any requirement for the Indenture Trustee to File any Proof of Claim, request for payment of Administrative Claim, fee application, or any other pleading or documents in the Chapter 11 Cases, or to provide itemized time details, and without reduction to recoveries on account of any of the Allowed Bond Claims. In the event the Portfolio Proceeds are insufficient to provide such payment (after taking into account the full amounts of the Initial Litigation Trust Funding Amount and the Wind Down Amount), the Indenture Trustee shall be issued New Series A1 WDT Interests on account of any unpaid amount of such Claim, and such unpaid amount of such Claim shall be satisfied via Cash distributions pursuant to the priority of payment waterfalls described in Article IV.H and

Article VI.C on account of the New Series A1 WDT Interests issued to the Indenture Trustee in respect of such unpaid amount pursuant to this Plan.

If the Debtors or Wind Down Debtors, as applicable, dispute any requested Indenture Fee and Expense Claims, the Debtors or the Wind Down Debtors, as applicable, shall: (a) pay the undisputed portion of the Indenture Fee and Expense Claims in accordance with this Plan; and (b) notify the Indenture Trustee and the Creditor Proponents of such dispute within two Business Days after presentment of summary invoices by the Indenture Trustee to the Debtors or the Wind Down Trustee, as applicable, and the Creditor Proponents. Upon such notification, the Indenture Trustee may submit such dispute for resolution by the Bankruptcy Court; *provided, however*, that the Bankruptcy Court's review shall be limited to a determination that such amounts are compensable under the Indenture Documents. Nothing herein shall in any way affect or diminish the right of the Indenture Trustee to exercise its Indenture Trustee Charging Lien against distributions on account of Claims under the Indenture Documents with respect to any Indenture Fee and Expense Claims that are not paid pursuant to this Article IV.T. The Indenture Trustee shall provide notice of any intent to exercise its Indenture Trustee Charging Lien against distributions on account of Claims under the Indenture Documents with respect to any unpaid Indenture Fee and Expense Claims to the Debtors or the Wind Down Trustee, as applicable, and the Creditor Proponents, and such parties shall have five (5) Business Days from service of such notice to File an objection with the Bankruptcy Court; *provided, however*, that the Bankruptcy Court's review shall be limited to a determination that such amounts are compensable under the Indenture Documents.

U. Beneficient SPAC Transaction Consents.

For the avoidance of doubt, prior to the Effective Date, any consents necessary in connection with approval of a special purpose acquisition company (SPAC) transaction of Beneficient shall require the consent of the Debtors and the Special Committee and shall be subject to Bankruptcy Court approval. For the avoidance of doubt, the required Bankruptcy Court approval may be contained in an order approving a proposed settlement with Beneficient. After the Effective Date, any such consents shall require the consent of the Wind Down Trustee and shall be subject to Bankruptcy Court approval. For the avoidance of doubt, after the Effective Date, such consent (and request for Bankruptcy Court approval by the Wind Down Trustee) may not include any releases or compromises of any Retained Causes of Action that are transferred to the Litigation Trust on the Effective Date without the consent of the Litigation Trustee.

V. Termination of Any Continuing Business Relationship With Beneficient.

For the avoidance of doubt, on and after the Effective Date, it is expected, whether as the result of the rejection of the Shared Services Agreement or a consensual resolution and termination thereof, that there will be no continuing or other business relationship between the Wind Down Debtors, Wind Down Trust, or Litigation Trust, on the one hand, and Beneficient, on the other, of any nature or type whatsoever, other than the Wind Down Trust's ownership of interests in Beneficient constituting the Wind Down Assets, except as may be necessary or advisable to effectuate a smooth transition of shared services from Beneficient to Portfolio Co. or the Wind Down Trust. The terms of any continued relationship with Beneficient, including any amounts

proposed to be paid to Beneficient, necessary to effect such transition shall be subject to the Proponents' Consent Right.

W. Compensation for Messrs. Stein and Horton.

On the Effective Date, the Debtors shall pay: (1) to Jeffrey S. Stein, a modified "Success Bonus" pursuant to Mr. Stein's Consulting Agreement (as defined in the CRO/ID Order), which shall be (a) \$1,830,000 in Cash, and (b) 40,000 common units of Beneficient owned by the Debtors, in each case to be paid on the Effective Date of this Plan; *provided, however*, that if Beneficient has consummated the special purpose acquisition company transaction of Beneficient prior to the Effective Date, Mr. Stein shall be entitled to receive 50,000 shares of Class A common stock, par value \$0.001 per share, of Beneficient, a Nevada corporation, owned by the Debtors; and (2) to Anthony R. Horton, additional compensation to the compensation payable in accordance with Mr. Horton's engagement letter in the amount of \$120,000 in Cash.

ARTICLE V.

TREATMENT OF EXECUTORY CONTRACTS AND UNEXPIRED LEASES

A. Assumption and Rejection of Executory Contracts and Unexpired Leases.

On the Effective Date, except as otherwise provided herein, all Executory Contracts or Unexpired Leases will be deemed rejected in accordance with the provisions and requirements of sections 365 and 1123 of the Bankruptcy Code, other than: (1) those that are identified on the Schedule of Assumed Executory Contracts and Unexpired Leases; (2) those that have been previously assumed, assumed and assigned, or rejected by a Final Order; (3) those that are the subject of a motion to assume, assume and assign, or reject Executory Contracts or Unexpired Leases that is pending on the Confirmation Date; (4) those that are subject to a motion to assume, assume and assign, or reject an Executory Contract or Unexpired Lease pursuant to which the requested effective date of such assumption, assumption and assignment, or rejection is after the Effective Date; or (5) those Executory Contracts and Unexpired Leases that expired pursuant to the terms thereof before the applicable Petition Date.

Entry of the Confirmation Order shall constitute a Final Order approving the assumptions, assumptions and assignments, or rejections of such Executory Contracts or Unexpired Leases as provided under this Plan or the Schedule of Assumed Executory Contracts and Unexpired Leases, pursuant to sections 365(a) and 1123 of the Bankruptcy Code. Unless otherwise indicated, assumptions or rejections of Executory Contracts and Unexpired Leases pursuant to this Plan are effective as of the Effective Date. Any motions to assume Executory Contracts or Unexpired Leases pending on the Effective Date shall be subject to approval by a Final Order of the Bankruptcy Court on or after the Effective Date.

To the extent any provision in any Executory Contract or Unexpired Lease assumed or assumed and assigned (as applicable) pursuant to this Plan or any prior order of the Bankruptcy Court (including, without limitation, any "change of control" provision) prohibits, restricts or conditions, or purports to prohibit, restrict or condition, or is modified, breached or terminated, or deemed modified, breached or terminated by (a) the commencement of these Chapter 11 Cases or the insolvency or financial condition of any Debtor at any time before the closing of its respective

Chapter 11 Case, (b) any Debtor's or Wind Down Debtor's assumption or assumption and assignment (as applicable) of such Executory Contract or Unexpired Lease, or (c) the Confirmation or Consummation of this Plan, then such provision shall be deemed modified such that the transactions contemplated by this Plan shall not entitle the non-Debtor party thereto to modify or terminate such Executory Contract or Unexpired Lease or to exercise any other default-related rights or remedies with respect thereto, and any required consent under any such Executory Contract or Unexpired Lease shall be deemed satisfied by the Confirmation of this Plan.

Rejection of any Executory Contract or Unexpired Lease pursuant to this Plan or otherwise shall not constitute a termination of any preexisting obligations owed to the Debtors or Wind Down Debtors, as applicable, under such Executory Contracts or Unexpired Leases.

B. Claims Based on Rejection of Executory Contracts or Unexpired Leases.

Proofs of Claim with respect to Claims arising from the rejection of Executory Contracts or Unexpired Leases, if any, must be Filed with the Bankruptcy Court within 30 days after the date of entry of an order of the Bankruptcy Court (including the Confirmation Order) approving such rejection. Any Claims arising from the rejection of an Executory Contract or Unexpired Lease not Filed within such time shall be automatically disallowed, forever barred from assertion, and shall not be enforceable against, as applicable, the Debtors, the Wind Down Debtors, the Wind Down Trustee, the Wind Down Trust, the Litigation Trust, or property of the foregoing parties, without the need for any objection by such parties and without the need for any further notice to, or action, order, or approval of the Bankruptcy Court or any other Entity, and any Claim arising out of the rejection of such Executory Contract or Unexpired Lease shall be deemed fully satisfied, released, and discharged, notwithstanding anything to the contrary in the Schedules or a Proof of Claim. Claims arising from the rejection of the Debtors' Executory Contracts or Unexpired Leases shall be classified as General Unsecured Claims in Class 4(a) or a GUC Convenience Claim in Class 4(b), depending on the amount of the Allowed Claim (or, to the extent the counterparty to the rejected Executory Contract or Unexpired Lease is one of the DLP Entities, Class 5), and shall be treated in accordance with Article III and Article IV.H of this Plan, as applicable.

C. Cure of Defaults for Assumed Executory Contracts and Unexpired Leases.

Any monetary defaults under an Executory Contract and Unexpired Lease, as reflected on the Schedule of Assumed Executory Contracts and Unexpired Leases, shall be satisfied, pursuant to section 365(b)(1) of the Bankruptcy Code, by payment of the Cure Amount in Cash on the Effective Date, subject to the limitations described below, or on such other terms as the parties to such Executory Contracts or Unexpired Leases may otherwise agree. In the event of a dispute regarding (1) the Cure Amount, (2) the ability of the Wind Down Debtors or any assignee to provide "adequate assurance of future performance" (within the meaning of section 365 of the Bankruptcy Code) under the Executory Contract or Unexpired Lease to be assumed, or (3) any other matter pertaining to assumption, the cure payments required by section 365(b)(1) of the Bankruptcy Code shall be made following the entry of a Final Order or orders resolving the dispute and approving the assumption.

In any case, if the Bankruptcy Court determines that the Allowed Cure Amount with respect to any Executory Contract or Unexpired Lease is greater than the amount set forth in the

Schedule of Assumed Executory Contracts and Unexpired Leases, the Debtors or the Wind Down Debtors, as applicable, will have the right to remove such Executory Contract or Unexpired Lease from the Schedule of Assumed Executory Contracts and Unexpired Leases, in which case such Executory Contract or Unexpired Lease will be deemed rejected as the Effective Date.

Assumption of any Executory Contract or Unexpired Lease pursuant to this Plan or otherwise shall result in the full release and satisfaction of any Claims or defaults, whether monetary or nonmonetary, including defaults of provisions restricting the change in control or ownership interest composition or other bankruptcy-related defaults, arising under any assumed Executory Contract or Unexpired Lease at any time before the date that the Debtors assume such Executory Contract or Unexpired Lease. Any Proofs of Claim Filed with respect to an Executory Contract or Unexpired Lease that has been assumed shall be deemed disallowed and expunged, without further notice to or action, order, or approval of the Bankruptcy Court.

Any objection regarding the ability of the Wind Down Debtors to provide “adequate assurance of future performance” (within the meaning of section 365 of the Bankruptcy Code) must have been Filed with the Bankruptcy Court by the deadline set by the Bankruptcy Court for objecting to Confirmation of the Plan. To the extent any such objection is not determined by the Bankruptcy Court at the Confirmation Hearing, such objection may be heard and determined at a subsequent hearing. Any counterparty to an Executory Contract or Unexpired Lease of the Debtors that does not timely object to such “adequate assurance of future performance” by such deadline will be deemed to have forever released and waived any such objection.

D. Insurance Policies.

Notwithstanding anything herein to the contrary, the Debtors shall retain the ability to supplement any D&O Liability Insurance Policies as the Debtors deem necessary, including purchasing any tail coverage. For the avoidance of doubt, prior to the Effective Date, the Debtors shall obtain additional director and officer liability tail insurance coverage for the period from April 20, 2022 to the Effective Date, which insurance coverage must not terminate or otherwise reduce the coverage set forth in the existing D&O Liability Insurance Policies. On and after the Effective Date, Portfolio Co., the Wind Down Trust, and the Litigation Trust, as applicable, shall be authorized to obtain additional director and officer or similar liability coverage for Portfolio Co., the Wind Down Trustee and the Litigation Trustee, as applicable, for the period following the Effective Date.

E. Modifications, Amendments, Supplements, Restatements, or Other Agreements.

Unless otherwise provided in this Plan, each Executory Contract or Unexpired Lease that is assumed shall include all modifications, amendments, supplements, restatements, or other agreements that in any manner affect such Executory Contract or Unexpired Lease, and Executory Contracts and Unexpired Leases related thereto, if any, including easements, licenses, permits, rights, privileges, immunities, options, rights of first refusal, and any other interests, unless any of

the foregoing agreements has been previously rejected or repudiated or is rejected or repudiated under the Plan.

Modifications, amendments, supplements, and restatements to prepetition Executory Contracts and Unexpired Leases that have been executed by the Debtors during the Chapter 11 Cases shall not be deemed to alter the prepetition nature of the Executory Contract or Unexpired Lease, or the validity, priority, or amount of any Claims that may arise in connection therewith.

F. Reservation of Rights.

Neither the exclusion nor inclusion of any Executory Contract or Unexpired Lease on the Schedule of Assumed Executory Contracts and Unexpired Leases, nor anything contained in the Plan, shall constitute an admission by the Debtors or any other Entity, as applicable, that any such contract or lease is in fact an Executory Contract or Unexpired Lease or that either any Debtor or any other Entity, as applicable, has any liability thereunder.

G. Non-occurrence of the Effective Date.

In the event that the Effective Date does not occur, the Bankruptcy Court shall retain jurisdiction with respect to any request to extend the deadline for assuming or rejecting Unexpired Leases pursuant to section 365(d)(4) of the Bankruptcy Code.

**ARTICLE VI.
PROVISIONS GOVERNING DISTRIBUTIONS**

A. Timing and Calculation of Amounts to Be Distributed.

Unless otherwise provided in this Plan or the Confirmation Order (and except with respect to Cash distributions from the Wind Down Trust or the Litigation Trust), on the Effective Date (or if a Claim is not an Allowed Claim on the Effective Date, on the date that such Claim becomes an Allowed Claim, or as soon as reasonably practicable thereafter), each Holder of an Allowed Claim entitled to a Cash distribution on the Effective Date shall receive the full amount of the distributions that the Plan provides for such Allowed Claim as set forth in Article III hereof. In the event that any payment or act under this Plan is required to be made or performed on a date that is not a Business Day, then the making of such payment or the performance of such act may be completed on the next succeeding Business Day, but shall be deemed to have been completed as of the required date. If and to the extent that there are Disputed Claims, distributions on account of any such Disputed Claims shall be made pursuant to Article VII (or, with respect to LBM, Article VI.C) hereof. Except as otherwise expressly provided in this Plan, Holders of Claims and Interests shall not be entitled to interest, dividends, or accruals on the distributions provided for herein, regardless of whether such distributions are delivered on or at any time after the Effective Date.

B. Distributing Parties.

After the Effective Date, all distributions under this Plan shall be made by or at the direction of the Wind Down Trustee on behalf of the Debtors or the Wind Down Trust, as applicable. The

Wind Down Trustee shall not be required to give any bond or surety or other security for the performance of its duties unless otherwise ordered by the Bankruptcy Court.

Subject to the terms of this Plan, the Wind Down Trustee shall be empowered to: (a) effect all actions and execute all agreements, instruments, and other documents necessary to perform its duties under the Plan; (b) make all distributions contemplated under the Plan; (c) employ professionals to represent it with respect to its responsibilities; and (d) exercise such other powers as may be vested in the Wind Down Debtors or the Wind Down Trustee, as applicable, by order of the Bankruptcy Court, pursuant to this Plan, or as deemed by the Wind Down Trustee to be necessary and proper to implement the provisions of hereof.

C. Delivery of Distributions Related to the Litigation Trust.

All distributions of the net proceeds realized by the Litigation Trust shall be made by the Wind Down Trustee (or by the Litigation Trustee, at the direction of the Wind Down Trustee) pursuant to the terms of this Plan and governed by the Litigation Trust Agreement.

Distributions of net proceeds realized by the Litigation Trust shall be made by the Wind Down Trustee, or by the Litigation Trustee at the direction of the Wind Down Trustee, in the following order of priority (with no distributions to junior classes until each senior class is paid in full):

1. to holders of New Series A1 WDT Interests (subject to prior payment in full of Indenture Fee and Expense Claims) on account of the Indenture Diminution Claims, up to the Allowed amount of such Claims;
2. on a *pari passu* pro rata basis (a) holders of the New Series A1 WDT Interests and the New Series A2 WDT Interests (subject to the prior payment in full of the Indenture Fee and Expense Claims and recognizing the intercreditor arrangements described in Article IV.H.1 through H.4 hereof vis-à-vis the New Series A1 WDT Interests and the New Series A2 WDT Interests), on the one hand, and (b) holders of New Series B WDT Interests on the other hand, up to the aggregate outstanding prepetition amounts of Allowed Bondholder Claims and Allowed LBM Subordinated Claims in Class 3, and Allowed Class 4(a) General Unsecured Claims, calculated in accordance with Article IV.H hereof;
3. on a *pari passu* pro rata basis (a) holders of the New Series A1 WDT Interests and the New Series A2 WDT Interests (subject to recognizing the intercreditor arrangements described in Article IV.H.1 through H.4 hereof vis-à-vis the New Series A1 WDT Interests and the New Series A2 WDT Interests), on the one hand, and (b) holders of New Series B WDT Interests on the other hand, up to the amount of interest accrued on such New Series A1 WDT Interests and New Series A2 WDT Interests as set forth in the New WDT Documents, and Allowed Class 4(a) General Unsecured Claims, calculated in accordance with Article IV.H hereof;
4. holders of New Series C WDT Interests and New Series D WDT Interests on a *pari passu* pro rata basis, per liquidation rights under the New WDT Documents and applicable law, up to the outstanding Allowed aggregate amount of the Class 8

Series 1 Preferred Interests and Class 9 Series 2 Preferred Interests (based on each Series 1 Preferred Interest and each Series 2 Preferred Interest having an initial stated value of \$1,000.00 per share); and

5. holders of the New Series E WDT Interests.

D. Delivery of Distributions and Undeliverable or Unclaimed Distributions.

1. Record Date for Distributions.

On the Distribution Record Date, the Claims Register shall be closed and any party responsible for making distributions shall instead be authorized and entitled to recognize only those record Holders listed on the Claims Register as of the close of business on the Distribution Record Date. Accordingly, any party responsible for making distributions will have no obligation to recognize the assignment, transfer or other disposition of, or the sale of any participation in, any Allowed Claim listed on the Claims Register that occurs after the close of business on the Distribution Record Date.

2. Delivery of Distributions in General.

Except as otherwise provided herein, the Wind Down Trustee shall make distributions to Holders of Allowed Claims and Allowed Interests as of the Distribution Record Date at the address for each such Holder as indicated on the Debtors' records as of the date of any such distribution; *provided*, that the manner of such distributions shall be determined at the discretion of the Wind Down Trustee; *provided, further*, that the address for each Holder of an Allowed Claim or Allowed Interest shall be deemed to be the address set forth in any Proof of Claim or Interest Filed by that Holder pursuant to Bankruptcy Rule 3001. If a Holder holds more than one Claim or Interest in any one Class, all Claims or Interests, as applicable, of the Holder will be aggregated into one Claim or Interest and one distribution will be made with respect to the aggregated Claim (to the extent possible). The Indenture Trustee Charging Lien shall attach to any distributions made to the Holders of Claims under the Indenture Documents in the same manner as if such distributions were made through the Indenture Trustee.

Notwithstanding any policies, practices, or procedures of DTC, DTC shall cooperate with and take all actions reasonably requested by the Wind Down Trustee or the Indenture Trustee to facilitate distributions to Holders of Allowed Bond Claims without requiring that such distributions be characterized as repayments of principal or interest. Neither the Wind Down Trustee nor the Indenture Trustee shall be required to provide indemnification or other security to DTC in connection with any distributions to Holders of Allowed Bond Claims through the facilities of DTC. The Indenture Trustee shall not incur any liability whatsoever on account of any distributions under this Plan.

3. Minimum Distributions.

Notwithstanding anything to the contrary herein, no Cash payment of less than \$100.00, in the reasonable discretion of the Wind Down Trustee, shall be made to a Holder of an Allowed Claim or Allowed Interest on account of such Allowed Claim or Allowed Interest. Each such Claim or Interest to which this limitation applies shall be discharged pursuant to Article VIII of

this Plan, and its Holder shall be forever barred pursuant to Article III hereof from asserting that Claim against or Interest in the Wind Down Debtors, the Wind Down Trustee, the Wind Down Trust, or the Litigation Trust, or any property of the foregoing.

No fractional interests of New WDT Interests shall be distributed and no Cash shall be distributed in lieu of such fractional amounts. When any distribution pursuant to the Plan on account of an Allowed Claim or Allowed Interest (as applicable) would otherwise result in the issuance of a number of New WDT Interests that is not a whole number, the actual distribution of New WDT Interests shall be rounded as follows: (a) fractions of one-half (1/2) or greater shall be rounded to the next higher whole number; and (b) fractions of less than one-half (1/2) shall be rounded to the next lower whole number with no further payment therefor. The total number of authorized New WDT Interests to be distributed to Holders of Allowed Claims and Allowed Interests shall be adjusted as necessary to account for the foregoing rounding.

4. Undeliverable Distributions and Unclaimed Property.

In the event that either (a) a distribution to any Holder is returned as undeliverable or (b) the Holder of an Allowed Claim or Allowed Interest does not timely respond to a request by the Debtors or the Wind Down Trustee for information necessary to facilitate a particular distribution, no distribution to such Holder shall be made unless and until the Wind Down Trustee is notified in writing of the then-current address of such Holder or the Wind Down Trustee has received the necessary information with sufficient time to facilitate a particular distribution, at which time such distribution shall be made to such Holder without interest, dividends, or other accruals of any kind; *provided*, that such distributions shall be deemed unclaimed property under section 347(b) of the Bankruptcy Code on the date that is six months after the later of (x) the Effective Date and (y) the date of the distribution; *provided, further*, that the Wind Down Trustee shall use commercially reasonable efforts to accurately determine the address or other contact information for any Holder (or holder, as applicable) that does not hold such Class 3 Bond Claims or New WDT Interests through DTC or by other indirect means before such distribution may be deemed unclaimed property. After such date, all unclaimed property or interests in property shall revert to the Wind Down Trust automatically and without need for a further order by the Bankruptcy Court (notwithstanding any applicable local, state, federal, or foreign escheat, abandoned, or unclaimed property laws to the contrary), and the Claim or Interest of any Holder to such property or interest in property shall be discharged and forever barred. For the avoidance of doubt, any unclaimed property in the form of Cash shall be distributed in accordance with Article III, Article IV.H, and Article VI.C of this Plan to Holders of Claims within the same Class to which the unclaimed property was to be distributed.

5. Manner of Payment Pursuant to the Plan.

Any payment in Cash to be made pursuant to the Plan shall be made at the election of the Wind Down Trustee by check or by wire transfer, at the sole and exclusive discretion of the Wind Down Trustee.

E. Single Satisfaction of Claims and Interests.

In no case shall the aggregate value of all property received or retained under this Plan on account of each Allowed Claim or Allowed Interest exceed 100% of the underlying Allowed Claim or Allowed Interest (plus any applicable interest).

F. No Postpetition Interest On Claims.

Unless otherwise specifically provided for in the Plan, the Confirmation Order, or Final Order of the Bankruptcy Court, or required by applicable bankruptcy or non-bankruptcy law (including, without limitation, as required pursuant to section 506(b) and section 511 of the Bankruptcy Code), postpetition interest shall not accrue or be paid on any prepetition Claims against the Debtors, and no Holder of a prepetition Claim against the Debtors shall be entitled to interest accruing on or after the applicable Petition Date on any such prepetition Claim. Additionally, and without limiting the foregoing, interest shall not accrue or be paid on any Disputed Claim with respect to the period from the Effective Date to the date a final distribution is made on account of such Disputed Claim, until such Disputed Claim becomes an Allowed Claim.

G. Compliance with Tax Requirements/Allocations.

In connection with the Plan and all distributions hereunder, to the extent applicable, the Debtors, the Wind Down Debtors, Wind Down Trustee, the Wind Down Trust, the Litigation Trust, and any applicable withholding agent shall comply with all tax withholding and reporting requirements imposed on them by any Governmental Unit, and all distributions made pursuant to the Plan shall be subject to such withholding and reporting requirements. Notwithstanding any provision in the Plan to the contrary, such parties shall (1) be authorized to take all actions necessary or appropriate to comply with such withholding and reporting requirements, including liquidating a portion of the distribution to be made under the Plan to generate sufficient funds to pay applicable withholding taxes, withholding distributions pending receipt of information necessary to facilitate such distributions, or establishing any other mechanisms they believe are reasonable and appropriate, and (2) shall reasonably cooperate with the relevant recipients to minimize any such withholding to the extent permitted by applicable law. The Debtors, the Wind Down Debtors, the Wind Down Trustee, the Wind Down Trust, and the Litigation Trust each reserve the right to allocate all distributions made under the Plan in compliance with all applicable wage garnishments, alimony, child support, and other spousal awards, Liens, and encumbrances.

Distributions in respect of Allowed Claims shall be allocated first to the principal amount of such Claims (as determined for federal income tax purposes) and then, to the extent the consideration exceeds the principal amount of the Claims, to any portion of such Claims for accrued but unpaid interest.

H. Setoffs.

Except as otherwise expressly provided for herein, the Wind Down Trustee, pursuant to the Bankruptcy Code (including section 553 of the Bankruptcy Code), applicable non-bankruptcy law, or as may be agreed to by the Holder of a Claim, may exercise setoff rights against any Allowed Claim and the distributions to be made pursuant to the Plan on account of such Allowed

Claim (before any distribution is made on account of such Allowed Claim), any claims, rights, and Causes of Action of any nature that such Debtor or Wind Down Debtor, as applicable, may hold against the Holder of such Allowed Claim, to the extent such claims, rights, or Causes of Action against such Holder have not been otherwise compromised or settled on or prior to the Effective Date (whether pursuant to the Plan or otherwise); *provided, however*, that neither the failure to effect such a setoff nor the allowance of any Claim pursuant to the Plan shall constitute a waiver or release by the Wind Down Trustee of any such claims, rights, and Causes of Action that the Wind Down Trustee may possess against such Holder; *provided, further*, that such Holder may contest any such set off by the Wind Down Trustee in the Bankruptcy Court or any other court of competent jurisdiction. For the avoidance of doubt, any such right of setoff may be preserved by timely Filing a Proof of Claim related to such right of setoff.

I. Allocation of Plan Distributions between Principal and Interest.

To the extent that any Allowed Claim entitled to a distribution under this Plan is comprised of indebtedness and accrued but unpaid interest thereon, such distribution shall, to the extent permitted by applicable law, be allocated for U.S. federal income tax purposes to the principal amount of the Claim first and then, to the extent that the consideration exceeds the principal amount of the Claim, to the portion of the Claim representing accrued but unpaid interest.

J. Claims Paid or Payable by Third Parties.

1. Claims Paid by Third Parties.

The Debtors or the Wind Down Trustee, as applicable, shall reduce in full a Claim, and such Claim shall be disallowed without a Claims objection having to be Filed and without any further notice to or action, order, or approval of the Bankruptcy Court, to the extent that the Holder of such Claim receives payment in full on account of such Claim from a party that is not a Debtor or the Wind Down Trustee. Subject to the last sentence of this paragraph, to the extent a Holder of a Claim receives a distribution on account of such Claim and receives payment from a party that is not a Debtor on account of such Claim, such Holder shall, within 14 days of receipt thereof, repay or return the distribution to the Wind Down Trustee to the extent the Holder's total recovery on account of such Claim from the third party and under the Plan exceeds the amount of such Claim as of the date of any such distribution under the Plan. The failure of such Holder to timely repay or return such distribution shall result in the Holder owing the Wind Down Trustee annualized interest at the Federal Judgment Rate on such amount owed for each Business Day after the 14-day grace period specified above until the amount is repaid.

2. Claims Payable by Third Parties.

Other than with respect to Class 3, no distributions under the Plan shall be made on account of a Claim that is payable by a third party (including by an Entity that is jointly and severally liable on such Claim and/or by one or more of the Debtors' insurers pursuant to one of the Debtors' insurance policies) until the Holder of such Claim has exhausted all rights and remedies with respect to such third party (including adjudicating any liability of any Entity that is jointly and severally liable on such Claim and/or adjudicating its rights under any applicable insurance policy). To the extent that any third party (including one or more of the Debtors' insurers) agrees

to satisfy in full or in part a Claim or such Claim is adjudicated by the Bankruptcy Court or another court of competent jurisdiction, the applicable portion of such Claim shall be automatically expunged without a Claims objection having to be Filed and without any further notice to or action, order, or approval of the Bankruptcy Court.

3. Applicability of Insurance Policies.

Except as otherwise provided in the Plan, distributions to Holders of Allowed Claims shall be in accordance with the provisions of any applicable insurance policy. Nothing contained in the Plan shall constitute or be deemed a waiver of any Cause of Action that the Debtors or any Entity may hold against any other Entity, including insurers under any policies of insurance, nor shall anything contained herein constitute or be deemed a waiver by such insurers of any defenses, including coverage defenses, held by such insurers.

ARTICLE VII. PROCEDURES FOR RESOLVING CONTINGENT, UNLIQUIDATED, AND DISPUTED CLAIMS

A. Allowance of Claims.

After the Effective Date, and subject to the terms of this Plan and the Confirmation Order, the Wind Down Trustee shall have and retain any and all rights and defenses such Debtor had with respect to any Claim or Interest immediately prior to the Effective Date. The Debtors may affirmatively determine to deem Unimpaired Claims Allowed to the same extent such Claims would be allowed under applicable non-bankruptcy law. No Claim shall become an Allowed Claim prior to the Claim Objection Bar Date unless and until such Claim is deemed Allowed under the Plan or the Bankruptcy Code, or the Bankruptcy Court has entered a Final Order (including the Confirmation Order) in the Chapter 11 Cases Allowing such Claim.

B. Claims Administration Responsibilities.

Except as otherwise specifically provided in the Plan, and notwithstanding any requirements that may be imposed pursuant to Bankruptcy Rule 9019, after the Effective Date, but not later than the Claims Objection Bar Date, the Wind Down Trustee shall have the sole authority: (1) to File, withdraw, or litigate to judgment objections to Claims or Interests (other than Claims or Interests deemed to be Allowed in this Plan); (2) to settle, compromise, or resolve any Disputed Claim or Disputed Interest without any further notice to or action, order, or approval by the Bankruptcy Court; and (3) to administer and adjust the Claims Register to reflect any such settlements or compromises without any further notice to or action, order, or approval by the Bankruptcy Court; *provided*, that, notwithstanding the foregoing, the Litigation Trustee shall have the sole authority to, on or before the Claims Objection Bar Date, File, withdraw, or litigate to judgment objections to Litigation Trust Reconciliation Claims, including any such Claims that are Disputed Claims or Interests. Notwithstanding the foregoing, the entry into any settlement of any Claim, settlement, or dispute with an economic value of \$5 million or more shall (on an individual basis) require the approval of the Bankruptcy Court after notice and an opportunity for a hearing. For the avoidance of doubt, except as otherwise provided herein, from and after the Effective Date, the Wind Down Trustee and the Litigation Trustee, as applicable, shall have and retain any and all

rights and defenses such Debtor had immediately prior to the Effective Date with respect to any Disputed Claim or Interest.

C. Estimation of Claims.

Before or after the Effective Date, the Debtors or Wind Down Debtors may (but are not required to), at any time, request that the Bankruptcy Court estimate any Disputed Claim or contingent or unliquidated Claim pursuant to applicable law, including pursuant to section 502(c) of the Bankruptcy Code and/or Bankruptcy Rule 3012, for any reason, regardless of whether any party previously has objected to such Claim or whether the Bankruptcy Court has ruled on any such objection, and the Bankruptcy Court shall retain jurisdiction under 28 U.S.C. §§ 157 and 1334 to estimate any such Claim, including during the litigation of any objection to any Claim or during the pendency of any appeal relating to such objection. Notwithstanding any provision otherwise in the Plan, a Claim that has been expunged from the Claims Register, but that either is subject to appeal or has not been the subject of a Final Order, shall be deemed to be estimated at zero dollars, unless otherwise ordered by the Bankruptcy Court. In the event that the Bankruptcy Court estimates any Claim, that estimated amount shall constitute a maximum limitation on such Claim for all purposes under the Plan (including for purposes of distributions) and may be used as evidence in any supplemental proceedings, and the Debtors or the Wind Down Trustee, as applicable, may elect to pursue any supplemental proceedings to object to any ultimate distribution on such Claim. Notwithstanding section 502(j) of the Bankruptcy Code, in no event shall any Holder of a Claim that has been estimated pursuant to section 502(c) of the Bankruptcy Code or otherwise be entitled to seek reconsideration of such estimation unless such Holder has Filed a motion requesting the right to seek such reconsideration on or before 7 days after the date on which such Claim is estimated. Each of the foregoing Claims and objection, estimation, and resolution procedures are cumulative and not exclusive of one another. Claims may be estimated and subsequently compromised, settled, withdrawn, or resolved by any mechanism approved by the Bankruptcy Court.

D. Adjustment to Claims or Interests without Objection.

Any duplicate Claim or Interest, any Claim or Interest that is substantiated by an invoice that is invalid, previously rejected, or otherwise deemed erroneous by the Debtors, or any Claim or Interest that has been paid, satisfied, amended, or superseded, may be adjusted or expunged on the Claims Register by the Debtors or the Wind Down Trustee, as applicable, without the Debtors or the Wind Down Trustee, as applicable, having to File an application, motion, complaint, objection, or any other legal proceeding seeking to object to such Claim or Interest and without any further notice to or action, order, or approval of the Bankruptcy Court.

E. Disallowance of Claims and Interests.

All Claims or Interests held by Entities from which property is recoverable under sections 542, 543, 550, or 553 of the Bankruptcy Code or that the Debtors, the Wind Down Trust, or the Litigation Trust, as applicable, allege is a transferee of a transfer avoidable under sections 522(f), 522(h), 544, 545, 547, 548, 549, or 724(a) of the Bankruptcy Code, shall be deemed disallowed pursuant to section 502(d) of the Bankruptcy Code, and Holders of such Claims or Interests may not receive any distributions on account of such Claims until such time as such

Causes of Action against that Entity have been settled or a Bankruptcy Court order with respect thereto has been entered and all sums due, if any, to the Debtors by that Entity have been turned over or paid to the Wind Down Trustee. All Proofs of Claim Filed on account of an indemnification obligation to a director, officer, or employee shall be deemed satisfied and expunged from the Claims Register as of the Effective Date to the extent such indemnification obligation is assumed (or honored or reaffirmed, as the case may be) pursuant to this Plan, without any further notice to or action, order, or approval of the Bankruptcy Court; *provided, however*, for the avoidance of doubt, no indemnification obligations of the Debtors to any former directors, officers, or employees of the Debtors or any other indemnification obligations of the Debtors arising from or relating to the prepetition period shall be assumed (provided, however, that nothing contained herein is intended to adversely affect any such director's, officer's, or employee's rights to an interest in Side A coverage under such policies).

Except as otherwise provided herein, if a party Files a Proof of Claim and the Debtors or the Wind Down Trustee, as applicable, do not determine, and without the need for notice to or action, order, or approval of the Bankruptcy Court, that the Claim subject to such Proof of Claim is Allowed, such Claim shall be Disputed unless Allowed or disallowed by a Final Order or as otherwise set forth in this Plan. Except as provided herein or otherwise agreed, any and all Proofs of Claim Filed after the applicable Claims Bar Date shall be deemed disallowed and forever barred, estopped, and enjoined from assertion and expunged as of the Effective Date without any further notice to or action, order, or approval of the Bankruptcy Court, and Holders of such Claims may not receive any distributions on account of such Claims, unless on or before the Confirmation Hearing such late Claim has been deemed timely Filed by a Final Order.

F. Disputed Claims Reserve.

On or before the Effective Date, the Debtors or the Wind Down Trustee, as applicable, shall deposit in the Disputed Claims Reserve the Disputed Claims Reserve Amount to the extent applicable and to the extent of Cash available or realized for distribution. The Wind Down Trustee shall administer the Disputed Claims Reserve and shall distribute amounts held in the Disputed Claims Reserve (net of any expenses, including any taxes relating thereto), as provided herein, as such Disputed Claims are resolved by a Final Order or agreed to by settlement, and such amounts will be distributable on account of such Disputed Claims as such amounts would have been distributable had such Disputed Claims been Allowed Claims as of the Effective Date solely to the extent of the amounts available in the applicable reserves. For the avoidance of doubt, any Cash held in the Disputed Claims Reserve on account of a Disputed Class 3 Bond Claim is ultimately disallowed by a Final Order or otherwise resolved between the Holder of the Disputed Claim and the Wind Down Debtors shall be distributed to other Holders of Class 3 Bond Claims in Accordance with Article III and Article IV.H of the Plan. The Wind Down Trustee (1) may timely elect to treat any Wind Down Trust Assets allocable to Disputed Claims as a “disputed ownership fund” governed by Treas. Reg. § 1.468B-9, and (2) to the extent permitted by applicable law, shall report consistently for state and local income tax purposes. If a “disputed ownership fund” election is made, all parties (including the Wind Down Trustee and New WDT Interests holders) shall report for United States federal, state and local income tax purposes consistently with the foregoing.

G. Amendments to Claims.

On or after the Effective Date, except as provided in the Plan or the Confirmation Order, a Claim or Interest may not be Filed or amended without the prior authorization of the Debtors or the Wind Down Debtors, as applicable, or the Bankruptcy Court, and any such new or amended Claim or Interest Filed shall be deemed disallowed in full and expunged without any further action, order, or approval of the Bankruptcy Court.

H. No Distributions Pending Allowance.

If an objection to a Claim or Interest or portion thereof is Filed as set forth in Article VII of this Plan, or if such Claim or Interest is scheduled as Disputed, no payment or distribution provided under the Plan shall be made on account of such Claim or Interest or any portion thereof unless and until such Disputed Claim or Disputed Interest becomes an Allowed Claim or Allowed Interest, unless otherwise determined by the Debtors or the Wind Down Trustee.

I. Distributions After Allowance.

To the extent that a Disputed Claim or Disputed Interest ultimately becomes an Allowed Claim or Allowed Interest, distributions (if any) shall be made to the Holder of such Allowed Claim or Allowed Interest in accordance with the provisions of this Plan. As soon as practicable after the date that the order or judgment of the Bankruptcy Court Allowing any Disputed Claim or Disputed Interest becomes a Final Order, the Wind Down Trustee shall provide to the Holder of such Claim or Interest the distribution (if any) to which such Holder is entitled under the Plan as of the Effective Date, less any previous distribution (if any) that was made on account of the undisputed portion of such Claim or Interest, without any interest, dividends, or accruals to be paid on account of such Claim or Interest unless required under applicable bankruptcy law or as otherwise provided in Article III.B of this Plan.

ARTICLE VIII.

SETTLEMENT, RELEASE, INJUNCTION, AND RELATED PROVISIONS

A. Settlement, Compromise, and Release of Claims and Interests.

Except as otherwise specifically provided in the Plan or in any contract, instrument, or other agreement or document created or entered into pursuant to the Plan, the distributions, rights, and treatment that are provided in the Plan shall be in complete satisfaction and release, effective as of the Effective Date, of Claims, Interests, and Causes of Action of any nature whatsoever, whether liquidated or unliquidated, fixed or contingent, matured or unmatured, including any interest accrued on Claims or Interests from and after the applicable Petition Date, whether known or unknown, against, liabilities of, Liens on, obligations of, rights against, and Interests in, the Debtors or any of their assets or properties, regardless of whether any property shall have been distributed or retained pursuant to the Plan on account of such Claims and Interests, including demands, liabilities, and Causes of Action that arose before the Effective Date, any liability (including withdrawal liability) to the extent such Claims or Interests relate to services performed by employees of the Debtors prior to the Effective Date and that arise from a termination of employment, any contingent or non-contingent liability on account of representations or warranties issued on or before the Effective Date, all debts of the kind specified in sections 502(g), 502(h),

or 502(i) of the Bankruptcy Code, in each case whether or not: (1) a Proof of Claim based upon such debt or right is Filed or deemed Filed pursuant to section 501 of the Bankruptcy Code; (2) a Claim or Interest based upon such debt, right, or interest is Allowed pursuant to section 502 of the Bankruptcy Code; or (3) the holder of such a Claim or Interest has accepted the Plan. The Confirmation Order shall be a judicial determination that the holders of Claims, Interests, and Causes of Action shall be limited to the distributions, if any, under this Plan for the satisfaction of such Claims, Interests, and Causes of Action against the Debtors and that, subject to the occurrence of the Effective Date, the distributions hereunder shall be in complete satisfaction of such Claims, Interests and Causes of Action insofar as the satisfaction of such Claims, Interests, and Causes of Action from any asset of the Debtors shall be concerned.

B. Release of Liens.

Except as otherwise provided herein or in any contract, instrument, release, or other agreement or document created pursuant to or in connection with the Plan, the Confirmation Order, or any contract, instrument, release, or other agreement or document created pursuant to the Plan, on the Effective Date and concurrently with the applicable distributions made pursuant to the Plan and, in the case of a Secured Claim, satisfaction in full of the portion of the Secured Claim that is Allowed as of the Effective Date, all mortgages, deeds of trust, Liens, pledges, or other security interests against any property of the Estates shall be fully released and discharged, and all of the right, title, and interest of any Holder of such mortgages, deeds of trust, Liens, pledges, or other security interests shall revert to the Debtors and their successors and assigns (including the Wind Down Debtors, Wind Down Trust, and/or the Litigation Trust, as applicable). Any Holder of such Secured Claim (and the applicable agents for such Holder) shall be authorized and directed, at the sole cost and expense of the Wind Down Trust, to release any collateral or other property of any Debtor or their successors and assigns (including the Wind Down Debtors, Wind Down Trust, and/or the Litigation Trust, as applicable), including any cash collateral and possessory collateral, held by such Holder (and the applicable agents for such Holder), and to take such actions as may be reasonably requested by the Wind Down Trust to evidence the release of such Lien, including the execution, delivery, and filing or recording of such releases. The presentation or filing of the Confirmation Order to or with any federal, state, provincial, or local agency or department shall constitute good and sufficient evidence of, but shall not be required to effect, the termination of such Liens.

C. Releases by the Debtors.

Pursuant to section 1123(b) of the Bankruptcy Code, in exchange for good and valuable consideration, the adequacy of which is hereby confirmed, on and after the Effective Date, each Released Party (but no Non-Released Party) is, and is deemed hereby to be, fully, conclusively, absolutely, unconditionally, irrevocably, and forever released and discharged by the Debtors, the Wind Down Debtors, and their Estates, and any person seeking to exercise the rights of the Debtors or their Estates, including any successors to the Debtors or any Estates representatives appointed or selected pursuant to section 1123(b)(3) of the Bankruptcy Code, in each case on behalf of themselves and their respective successors, assigns, and representatives, and any and all other Entities who may purport to assert any Cause of Action, directly or derivatively, by, through or for the Debtors or their Estates,

from any and all Claims and Causes of Action, whether known or unknown, including any derivative claims, asserted or assertable on behalf of the Debtors, whether known or unknown, foreseen or unforeseen, matured or unmatured, existing or hereafter arising, contingent or non-contingent, in law, equity, contract, tort or otherwise, except for any claims related to any act or omission that is determined in a Final Order to have constituted actual fraud, willful misconduct, intentional breach of fiduciary duty, or gross negligence, that the Debtors, the Wind Down Debtors, or their Estates, including any successors to the Debtors or any Estates representative appointed or selected pursuant to section 1123(b) of the Bankruptcy Code, would have been legally entitled to assert in their own right (whether individually or collectively) or on behalf of the Holder of any Claim or Interest in, a Debtor or other Entity, or that any Holder of any Claim against, or Interest in, a Debtor or other Entity could have asserted on behalf of the Debtors, based on or relating to, or in any manner arising from, in whole or in part, the Debtors (including the capital structure, management, ownership or operation thereof), the business or contractual arrangement between the Debtors and any Released Party, any Securities issued by the Debtors and the ownership thereof, the assertion or enforcement of rights and remedies against the Debtors, the Debtors' in- or out-of-court restructuring efforts, any Avoidance Actions (but excluding Avoidance Actions brought as counterclaims or defenses to Claims asserted against the Debtors), intercompany transactions between or among a Debtor and another Debtor, the formulation, preparation, dissemination, negotiation, or Filing of the Disclosure Statement, the Plan (including, for the avoidance of doubt, the Plan Supplement), the Vida DIP Financing Facility, the Vida Exit Financing Facility, or any Wind Down Transaction, contract, instrument, release, or other agreement or document (including any legal opinion requested by any Entity regarding any transaction, contract, instrument, document or other agreement contemplated by the Plan or the reliance by any Released Party on the Plan or the Confirmation Order in lieu of such legal opinion) created or entered into in connection with the Disclosure Statement, the Vida Exit Financing Facility Documents, the Plan, or the Plan Supplement, before or during the Chapter 11 Cases, the Chapter 11 Cases, the filing of the Chapter 11 Cases, the pursuit of Confirmation, the administration and implementation of the Plan, including the issuance or distribution of Securities pursuant to the Plan, or the distribution of property under the Plan, or upon any related act or omission, transaction, agreement, event, or other occurrence related or relating to any of the foregoing taking place on or before the Effective Date related or relating to the foregoing including all relief obtained by the Debtors in the Chapter 11 Cases. For the avoidance of doubt, the LBM Released Parties, to the extent that LBM has not withdrawn from the settlement described in Article IV.I of this Plan, shall constitute Released Parties with respect to this Debtor Release.

Notwithstanding anything to the contrary in the foregoing, the releases set forth above do not release: (1) post-Effective Date obligations of any party or Entity under the Plan, the Confirmation Order, any Wind Down Transaction, or any other document, instrument, or agreement (including those set forth in the Plan Supplement) executed to implement the Plan, including the Vida Exit Financing Facility Documents, or any Claim or obligation arising under the Plan; (2) the rights of any Holder of Allowed Claims to receive distributions under the Plan; (3) the Retained Causes of Action; (4) any claims related to any act or omission that is determined in a Final Order to have constituted actual fraud, willful misconduct, intentional breach of fiduciary duty, or gross negligence; (5) the Debtors'

prepetition legal counsel solely with respect to claims or causes of action arising from such counsel's prepetition advice to the Debtors and/or any former directors or officers of the Debtors other than advice directly relating to the preparation and filing of the Chapter 11 Cases (it being understood any prepetition advice to the Debtors relating to prepetition transactions between the Debtors and Beneficient shall not constitute advice directly relating to the preparation and filing of the Chapter 11 Cases); or (6) any Non-Released Party.

Entry of the Confirmation Order shall constitute the Bankruptcy Court's approval, pursuant to Bankruptcy Rule 9019, of the foregoing Debtor Release, which includes by reference each of the related provisions and definitions contained in the Plan, and further, shall constitute the Bankruptcy Court's finding that the Debtor Release is: (a) in exchange for the good and valuable consideration provided by the Released Parties, including, without limitation, the Released Parties' contributions to facilitating the Wind Down Transactions and implementing the Plan; (b) a good faith settlement and compromise of the Claims released by the Debtor Release; (c) in the best interests of the Debtors and all holders of Claims and Interests; (d) fair, equitable, and reasonable; (e) given and made after due notice and opportunity for hearing; and (f) a bar to any of the Debtors, the Wind Down Debtors, or the Debtors' Estates asserting any Claim or Cause of Action released pursuant to the Debtor Release.

D. *[RESERVED.]*

[RESERVED.]

E. *Exculpation.*

Except as otherwise expressly stated in this Plan or the Confirmation Order, as of the Effective Date, each Exculpated Party shall be deemed to be released and exculpated from any claim, obligation, Cause of Action, or liability for any Exculpated Claim, except for claims related to any act or omission that is determined in a Final Order to have constituted intentional breach of fiduciary duty, actual fraud, willful misconduct, or gross negligence, but in all respects each Debtor and each Exculpated Party shall be entitled to reasonably rely upon the advice of counsel with respect to their duties and responsibilities pursuant to the Plan. The Exculpated Parties have, and upon the Consummation of the Plan, shall be deemed to have, participated in good faith and in compliance with applicable law with regard to the restructuring of Claims and Interests in the Chapter 11 Cases and in connection with the Wind Down Transactions, the negotiation, formulation, or preparation of the Wind Down Documents or related agreements, instruments, or other documents (including, for the avoidance of doubt, providing any legal opinion requested by any Entity regarding any transaction, contract, instrument, document, or other agreement contemplated by the Plan or the reliance by any Released Party on the Plan or the Confirmation Order in lieu of such legal opinion) in connection with the Plan, and the solicitation of the Plan and distributions pursuant to the Plan and, therefore, are not, and on account of such distributions shall not be, liable at any time for the violation of any applicable law, rule, or regulation governing the solicitation of acceptances or rejections of the Plan or such distributions made pursuant to the Plan, except for claims related to any act or omission that is determined in a Final Order to have constituted intentional breach of fiduciary duty, actual fraud, willful

misconduct, or gross negligence. The Debtors and the Creditor Proponents agree that (1) neither the act itself of Filing or prosecuting a motion to approve a settlement of any Estate Causes of Action with Beneficient, any of its Affiliates or related parties, and/or any other Non-Released Party nor the act itself of Filing or prosecuting any objection to any such settlement in and of itself constitutes an intentional breach of fiduciary duty, and (2) any claims that the Debtors or the Creditor Proponents may seek to bring against any Exculpated Party shall be limited to any actions of such Exculpated Party solely after the date of execution of the Mediation Agreement; *provided* that any such claims must be Filed exclusively in the Bankruptcy Court and in accordance with the Federal Rules of Civil Procedures, and such claims shall be pled with specificity with respect to the who, what, when, where, and how of the alleged wrongful conduct.

F. Protections Against Discriminatory Treatment after the Effective Date.

In accordance with section 525 of the Bankruptcy Code, and consistent with paragraph 2 of Article VI of the United States Constitution, no Governmental Unit shall discriminate against any Wind Down Debtor, or any Entity with which a Wind Down Debtor has been or is associated (including the Wind Down Trustee), solely because such Wind Down Debtor was a Debtor under Chapter 11 of the Bankruptcy Code, may have been insolvent before the commencement of the Chapter 11 Cases (or during the Chapter 11 Cases but before such Debtor was granted or denied a discharge), or has not paid a debt that is dischargeable in the Chapter 11 Cases. For the avoidance of doubt, 28 U.S.C. § 959(b) shall apply.

G. Injunction.

Except as otherwise expressly provided in the Plan or the Confirmation Order or for obligations or distributions required to be paid pursuant to the Plan or the Confirmation Order, all Entities who have held, hold, or may hold claims that have been released pursuant to Article VIII hereof are permanently enjoined, from and after the Effective Date, from taking any of the following actions against, as applicable, the Debtors, the Released Parties, or the Exculpated Parties: (1) commencing or continuing in any manner any action or other proceeding of any kind on account of or in connection with or with respect to any of the claims or interests released hereunder; (2) enforcing, attaching, collecting, or recovering by any manner or means any judgment, award, decree, or order against such Entities on account or in connection with or with respect to any claims or interests released hereunder; (3) creating, perfecting, or enforcing any Lien or encumbrance of any kind against such Entities or the property of such Entities on account or in connection with or with respect to any claims or interests released hereunder; (4) asserting any right of setoff, subrogation, or recoupment of any kind against any obligation due from such Entities or against the property or the Estates of such Entities on account or in connection with or with respect to any claims or interests released hereunder, unless such holder has Filed a motion requesting the right to perform such setoff on or before the Effective Date, and notwithstanding an indication of a Claim or Interest or otherwise that such Holder asserts, has, or intends to preserve any right of setoff pursuant to applicable law or otherwise; and (5) commencing or continuing in any manner any action or other proceeding of any kind on account of or in connection with or with respect to any claims or interests released or settled pursuant to this Plan.

Upon entry of the Confirmation Order, all Holders of Claims and Interests and their respective current and former employees, agents, officers, directors, principals, and direct and indirect Affiliates shall be enjoined from taking any actions to interfere with the implementation or Consummation of this Plan. Except as otherwise set forth in the Confirmation Order, each Holder of an Allowed Claim or Allowed Interest, as applicable, by accepting, or being eligible to accept, distributions under this Plan shall be deemed to have consented to the injunction provisions set forth herein.

H. Recoupment.

In no event shall any Holder of Claims or Interests be entitled to recoup any Claim or Interest against any claim, right, or Cause of Action of the Debtors, the Wind Down Debtors, the Wind Down Trustee, the Wind Down Trust, or the Litigation Trust, as applicable, unless such Holder actually has performed such recoupment and provided notice thereof in writing to the Debtors on or before the Confirmation Date, notwithstanding any indication in any Proof of Claim or Interest or otherwise that such Holder asserts, has, or intends to preserve any right of recoupment.

I. Subordination Rights.

The classification and treatment of all Claims and Interests under the Plan shall conform to and with the respective contractual, legal, and equitable subordination rights of such Claims and Interests, and may only be modified upon entry of a Final Order approving or directing the settlement, compromise, release, and/or other alteration of any such rights.

K Document Retention.

On and after the Effective Date, the Wind Down Debtors, the Wind Down Trustee, the Wind Down Trust, and the Litigation Trust, as applicable, may maintain documents in accordance with the Wind Down Debtors' standard document retention policy, as may be altered, amended, modified, or supplemented by the Wind Down Debtors, Wind Down Trust, Wind Down Trustee, or the Litigation Trust, as applicable.

J. Ipso Facto and Similar Provisions Ineffective.

To the extent permitted by applicable law, any term of any prepetition policy, contract, or other obligation applicable to the Debtors shall be void and of no further force or effect to the extent that such policy, contract, or other obligation is conditioned on, creates an obligation as a result of, or gives rise to a right of any Entity based on: (1) the insolvency or financial condition of a Debtor; (2) the commencement of any of the Chapter 11 Cases; (3) either the Confirmation or Consummation of the Plan; or (4) any of the Wind Down Transactions.

K. Reimbursement or Contribution.

If the Bankruptcy Court disallows a Claim for reimbursement or contribution of an Entity pursuant to section 502(e)(1)(B) of the Bankruptcy Code, then to the extent that such Claim is contingent as of the time of allowance or disallowance, such Claim shall be forever disallowed and expunged notwithstanding section 502(j) of the Bankruptcy Code, unless before the

Confirmation Date: (1) such Claim has been adjudicated as non-contingent or (2) the relevant Holder of a Claim has Filed a non-contingent Proof of Claim on account of such Claim and a Final Order has been entered before the Confirmation Date determining such Claim as no longer contingent.

ARTICLE IX.
CONDITIONS PRECEDENT TO CONFIRMATION AND THE EFFECTIVE DATE

A. Conditions Precedent to the Effective Date.

It shall be a condition to Consummation that the following conditions shall have been satisfied or waived pursuant to the provisions of Article IX.C hereof:

- (a) the Bankruptcy Court shall have entered the Confirmation Order, subject to the Proponents' Consent Right, and such order shall have become a Final Order that has not been stayed, modified, or vacated on appeal, subject to the Debtors' right to waive any appeal period (with the reasonable consent of the Creditor Proponents);
- (b) the Debtors shall have assumed the D&O Liability Insurance Policies, which shall include, for the avoidance of doubt, policies that provide coverage for periods and were purchased prior to April 20, 2022;
- (c) the Debtors shall have obtained additional director and officer liability tail insurance coverage for the period from April 20, 2022 to the Effective Date, which insurance coverage must not terminate or otherwise reduce the coverage set forth in the existing D&O Liability Insurance Policies, the form and substance of which being subject to the Proponents' Consent Right;
- (d) the Vida Exit Financing Facility Documents shall have been executed, delivered, be in full force and effect (with all conditions precedent thereto having been satisfied or waived), and any amendments, modifications or supplements to the Vida Exit Financing Facility Documents that were Filed at Docket No. 975 shall be in form and substance subject to the Proponents' Consent Right;
- (e) the Investigations Committee shall have completed its independent investigation with respect to any releases granted pursuant to this Plan;
- (f) the Wind Down Trust Agreement shall have been executed and shall be in form and substance subject to the Proponents' Consent Right;
- (g) the Wind Down Budget shall have been delivered to the Creditor Proponents and shall be in form and substance subject to the Proponents' Consent Right;

- (h) the Wind Down Trust Assets shall have been transferred to the Wind Down Trust;
- (i) the Wind Down Trustee shall have accepted the appointment;
- (j) the Litigation Trust Agreement shall have been executed and shall be in form and substance subject to the Proponents' Consent Right;
- (k) the Litigation Trustee shall have been appointed and have accepted the appointment;
- (l) the Initial Litigation Trust Assets shall have been transferred to the Litigation Trust;
- (m) the New WDT Interests shall have been issued
- (n) the New WDT Documents shall be in form and substance subject to the Proponents' Consent Right;
- (o) any Plan Supplement documents, including any exhibits, schedules, amendments, modifications, or supplements thereto, not otherwise identified above in this Article IX.A, shall have been Filed and shall be in form and substance subject to the Proponents' Consent Right;
- (p) all governmental and material third party approvals and consents, including Bankruptcy Court approval, necessary in connection with the transactions contemplated by the Plan shall have been obtained, not be subject to unfulfilled conditions and be in full force and effect, and all applicable waiting periods shall have expired without any action being taken or threatened by any competent authority that would restrain, prevent, or otherwise impose materially adverse conditions on such transactions; *provided*, it being understood that any 1940 Act matters in connection with the Wind Down Trust shall be addressed as set forth in Article IV.A herein;
- (q) the Professional Fee Escrow Account shall have been funded with Cash in the amount of the aggregate Professional Fee Escrow Amount for all Professionals;
- (r) to the extent of Cash distributions would apply to any such Disputed Claims, and to the extent that Cash is available, the Disputed Claims Reserve shall have been established and funded; and
- (s) any other corporate or related actions necessary or advisable in the reasonable business judgment of the Debtors and subject to the Proponents' Consent Right for the Plan to become effective shall have been taken.

B. Effect of Non-Occurrence of Conditions Precedent to Consummation.

If the Effective Date does not occur, then: (1) this Plan will be null and void in all respects; and (2) nothing contained in the Plan or the Disclosure Statement shall (a) constitute a waiver or release of any Claims, Interests, or Causes of Action by an Entity, (b) prejudice in any manner the rights of any Debtor or any other Entity, (c) constitute an admission, acknowledgment, offer, or undertaking of any sort by any Debtor or any other Entity, or (d) constitute an Allowance of any Claim or Interest.

C. Waiver of Conditions Precedent.

The conditions to Confirmation and Consummation set forth in Article IX of this Plan, other than the condition that the Confirmation Order has been entered by the Bankruptcy Court, may be waived only by prior written consent of the Debtors and the Creditor Proponents (subject to the Proponents' Consent Rights), without notice, leave, or order of the Bankruptcy Court or any formal action other than proceedings to confirm or consummate the Plan. Upon the occurrence of all the conditions to Confirmation and Consummation set forth in Article IX of this Plan, the Debtor shall immediately declare the Effective Date. The failure of the Debtors, the Wind Down Debtors, the Wind Down Trustee, or the Creditor Proponents, as applicable, to exercise any of the foregoing rights shall not be deemed a waiver of any other rights, and each such right shall be deemed an ongoing right that may be asserted at any time.

ARTICLE X.

MODIFICATION, REVOCATION, OR WITHDRAWAL OF THE PLAN

A. Modification and Amendments.

Except as otherwise specifically provided in the Plan, the Debtors reserve the right to modify this Plan subject to the Proponents' Consent Right or whether materially or immaterially, and seek Confirmation, in each instance, to the extent permitted under the Bankruptcy Code. Subject to certain restrictions and requirements set forth in section 1127 of the Bankruptcy Code and Bankruptcy Rule 3019 and those restrictions on modifications set forth in the Plan, the Debtors expressly reserve their rights to alter, amend, or modify materially the Plan, subject to the Proponents' Consent Right, one or more times, after Confirmation, and, to the extent necessary, may initiate proceedings in the Bankruptcy Court, subject to the Proponents' Consent Right, to so alter, amend, or modify the Plan, or remedy any defect or omission, or reconcile any inconsistencies in the Plan, the Disclosure Statement, or the Confirmation Order, in such matters as may be necessary to carry out the purposes and intent of this Plan. Notwithstanding the foregoing and for the avoidance of doubt, any such modification or amendments pursuant to this Article X.A shall be consistent in all material respects with the Mediation Agreement. Any such modification or supplement shall be considered a modification of this Plan and shall be made in accordance with Article X of this Plan.

B. Effect of Confirmation on Modifications.

Entry of a Confirmation Order shall mean that all modifications or amendments to this Plan occurring after the solicitation thereof and before the Confirmation Date are approved pursuant to

section 1127(a) of the Bankruptcy Code and do not require additional disclosure or resolicitation under Bankruptcy Rule 3019.

C. Revocation or Withdrawal of the Plan.

The Debtors reserve the right, with the consent of the Creditor Proponents, to revoke or withdraw the Plan with respect to one or more of the Debtors before the Confirmation Date or the Effective Date and to File subsequent plans under chapter 11 of the Bankruptcy Code. If the Debtors revoke or withdraw the Plan with respect to any Debtor, or if Confirmation or Consummation does not occur with respect to any Debtor, then: (1) the Plan with respect to such Debtor shall be null and void in all respects; (2) any settlement or compromise embodied in the Plan with respect to such Debtor (including the fixing or limiting to an amount certain of any Claim or Interest or Class of Claims or Interests), assumption and assignment or rejection of Executory Contracts or Unexpired Leases effected by the Plan with respect to such Debtor, and any document or agreement executed pursuant to the Plan with respect to such Debtor, shall be deemed null and void; and (3) nothing contained in the Plan with respect to such Debtor shall (a) constitute a waiver or release of any Claims or Interests, (b) prejudice in any manner the rights of the Debtors or any other Entity, or (c) constitute an admission, acknowledgement, offer, or undertaking of any sort by the Debtors or any other Entity.

Notwithstanding any provision of this Article X or otherwise in this Plan to the contrary, the Debtors and any of the Debtors' directors, managers, and officers shall maintain the right to exercise their fiduciary duties in accordance with applicable law.

**ARTICLE XI.
RETENTION OF JURISDICTION**

Notwithstanding the entry of the Confirmation Order and the occurrence of the Effective Date, on and after the Effective Date, the Bankruptcy Court shall retain exclusive jurisdiction over the Chapter 11 Cases and all matters, arising out of, or related to, the Chapter 11 Cases and the Plan pursuant to sections 105 and 1142 of the Bankruptcy Code, including jurisdiction to:

1. allow, disallow, determine, liquidate, classify, estimate, or establish the priority, Secured or unsecured status, or amount of any Claim or Interest, including the resolution of any request for payment of any Claim or Interest and the resolution of any and all objections to the Secured or unsecured status, priority, amount, or allowance of Claims or Interests;
2. decide and resolve all matters related to the granting and denying, in whole or in part, any applications for allowance of compensation or reimbursement of expenses to Professionals authorized pursuant to the Bankruptcy Code or the Plan;
3. resolve any matters related to: (a) the assumption, assumption and assignment, or rejection of any Executory Contract or Unexpired Lease to which a Debtor is party or with respect to which a Debtor may be liable in any manner and to hear, determine, and, if necessary, liquidate, any Claims arising therefrom, including Claims related to the rejection of an Executory Contract or Unexpired Lease, Cure Amounts pursuant to section 365 of the Bankruptcy Code, or any other matter related to such Executory Contract or Unexpired Lease; (b) any potential contractual obligation under any Executory Contract or Unexpired Lease that is assumed and/or assigned;

(c) the Debtors amending, modifying, or supplementing, after the Effective Date, pursuant to Article V of the Plan, any Executory Contracts or Unexpired Leases to the Schedule of Assumed Executory Contracts and Unexpired Leases or otherwise; and (d) any dispute regarding whether a contract or lease is or was executory or expired;

4. ensure that distributions to Holders of Allowed Claims and Allowed Interests are accomplished pursuant to the provisions of the Plan and adjudicate any and all disputes arising from or relating to distributions under the Plan or any transactions contemplated therein;

5. adjudicate, decide, or resolve any motions, adversary proceedings, contested or litigated matters, and any other matters, and grant or deny any applications involving a Debtor that may be pending on the Effective Date;

6. adjudicate, decide, or resolve any and all matters related to the Retained Causes of Action;

7. enter and implement such orders as may be necessary or appropriate to execute, implement, or consummate the provisions of the Plan and all contracts, instruments, releases, indentures, and other agreements or documents created in connection with the Plan or the Disclosure Statement;

8. enforce any order for the sale of property pursuant to sections 361, 1123, or 1146(a) of the Bankruptcy Code;

9. grant any consensual request to extend the deadline for assuming or rejecting Unexpired Leases pursuant to section 365(d)(4) of the Bankruptcy Code;

10. resolve any cases, controversies, suits, disputes, or Causes of Action that may arise in connection with the Consummation, interpretation, or enforcement of the Plan or any Entity's obligations incurred in connection with the Plan;

11. issue injunctions, enter and implement other orders, or take such other actions as may be necessary or appropriate to restrain interference by any Entity with Consummation or enforcement of the Plan;

12. resolve any cases, controversies, suits, disputes, or Causes of Action with respect to the settlements, compromises, releases, injunctions, exculpations, and other provisions contained in Article VIII of this Plan and enter such orders as may be necessary or appropriate to implement such releases, injunctions, and other provisions;

13. resolve any cases, controversies, suits, disputes, or Causes of Action with respect to the repayment or return of distributions and the recovery of additional amounts owed by the Holder of a Claim or Interest for amounts not timely repaid pursuant to Article VI.E of this Plan;

14. enter and implement such orders as are necessary or appropriate if the Confirmation Order is for any reason modified, stayed, reversed, revoked, or vacated;

15. determine any other matters that may arise in connection with or relate to the Plan, the Disclosure Statement, the Confirmation Order, the Wind Down Trust Agreement, the Litigation Trust Agreement, the Vida Exit Financing Facility Documents, or any contract, instrument, release, indenture, or other agreement or document created in connection with the Plan or the Disclosure Statement;
16. decide and resolve all matters related to the issuance of New WDT Interests;
17. consider any modifications of the Plan, to cure any defect or omission, or to reconcile any inconsistency in any Bankruptcy Court order, including the Confirmation Order;
18. determine requests for the payment of Claims and Interests entitled to priority pursuant to section 507 of the Bankruptcy Code;
19. hear and determine disputes arising in connection with the interpretation, implementation, or enforcement of the Plan, or the Confirmation Order, including disputes arising under agreements, documents, or instruments executed in connection with the Plan;
20. hear and determine matters concerning state, local, and federal taxes in accordance with sections 346, 505, and 1146 of the Bankruptcy Code;
21. hear and determine matters concerning section 1145 of the Bankruptcy Code;
22. hear and determine all disputes involving the existence, nature, or scope of the Debtor Release, including any dispute relating to any liability arising out of the termination of employment or the termination of any employee or retiree benefit program, regardless of whether such termination occurred before or after the Effective Date;
23. enforce all orders previously entered by the Bankruptcy Court;
24. hear any other matter not inconsistent with the Bankruptcy Code;
25. enter an order concluding or closing the Chapter 11 Cases; and
26. Enforce the injunction, release, and exculpation provisions set forth in Article VIII hereof.

ARTICLE XII.
MISCELLANEOUS PROVISIONS

A. *Immediate Binding Effect.*

Subject to Article IX of this Plan and notwithstanding Bankruptcy Rules 3020(e), 6004(h), or 7062 or otherwise, upon the occurrence of the Effective Date, the Plan and the Plan Supplement shall be immediately effective and enforceable and deemed binding upon the Debtors, any and all Holders of Claims or Interests (irrespective of whether the Holders of such Claims or Interests accepted or rejected the Plan), all Entities that are parties to or are subject to the settlements, compromises, releases, and injunction described in the Plan, each Entity acquiring property under

the Plan, and any and all non-Debtor parties to Executory Contracts and Unexpired Leases with the Debtors. All Claims against and Interests in the Debtors shall be fixed, adjusted, or compromised, as applicable, pursuant to the Plan regardless of whether any Holder of a Claim or Interest has voted on the Plan.

B. Additional Documents.

On or before the Effective Date, the Debtors may File with the Bankruptcy Court such agreements and other documents as may be necessary or appropriate to effectuate and further evidence the terms and conditions of the Plan. The Debtors, all Holders of Claims or Interests receiving distributions pursuant to the Plan, and all other parties in interest shall, from time to time, prepare, execute, and deliver any agreements or documents and take any other actions as may be necessary or advisable to effectuate the provisions and intent of the Plan.

C. Payment of Statutory Fees.

All fees payable under section 1930 of chapter 123 of title 28 of the United States Code shall be paid on the Effective Date, or as soon as practicable thereafter, by the Debtors or Wind Down Debtors. Quarterly fees owed to the U.S. Trustee shall be paid when due in accordance with applicable law and the Debtors and Wind Down Debtors shall continue to file reports to show the calculation of such fees for the Debtors' Estates until the Chapter 11 Cases are closed under section 350 of the Bankruptcy Code. Each and every one of the Debtors shall remain obligated to pay quarterly fees to the U.S. Trustee until the earliest of that particular Debtor's case is closed, dismissed, or converted to a case under chapter 7 of the Bankruptcy Code.

D. Dissolution of the Bondholder Committee.

On the Effective Date, any statutory committee appointed in the Chapter 11 Cases (including the Bondholder Committee) shall dissolve and members thereof shall be released and discharged from all rights and duties from or related to the Chapter 11 Cases; *provided, however*, that following the Effective Date, the Bondholder Committee will continue in existence and have standing and a right to be heard for the following limited purposes: (1) adjudication of any final fee applications Filed pursuant to sections 330 and 331 of the Bankruptcy Code in accordance with the Plan; and (2) any (a) appeals of the Confirmation Order, and (b) any appeals, prosecution, or defense of any Causes of Action or proceedings with respect to which the Bondholder Committee is a party as of the Effective Date. Following the completion of the Bondholder Committee's remaining duties set forth above, the Bondholder Committee will be dissolved, and the retention or employment of the Bondholder Committee's respective attorneys, accountants and other agents will terminate without further notice to, or action by, any Entity. The Wind Down Debtors shall be responsible for fees incurred in connection with the foregoing purposes only and shall be paid in the ordinary course from the Professional Fee Escrow Account without need for Bankruptcy Court approval.

E. Reservation of Rights.

The Plan shall have no force or effect unless the Bankruptcy Court shall enter the Confirmation Order. Neither the Plan, any statement or provision contained in the Plan, nor any action taken or not taken by any Debtor, any Wind Down Debtor, the Wind Down Trustee, the

Wind Down Trust, or the Litigation Trust with respect to the Plan or any other Wind Down Document shall be or shall be deemed to be an admission or waiver of any rights of any such parties with respect to the Holders of Claims or Interests before the Effective Date.

F. Successors and Assigns.

The rights, benefits, and obligations of any Entity named or referred to in the Plan or the Confirmation Order shall be binding on, and shall inure to the benefit of any heir, executor, administrator, successor, or assign, Affiliate, officer, director, manager, trustee, agent, representative, attorney, beneficiaries, or guardian, if any, of each Entity.

G. Service of Documents.

Any pleading, notice, or other document required by the Plan to be served on or delivered to the Debtors shall be served on:

GWG Holdings, Inc.
Attn.: Jeffrey S. Stein
325 N. St. Paul Street, Suite 2650
Dallas, Texas 7520
E-mail address: jstein@steinadvisorsllc.com

with copies to:

Jackson Walker LLP
1401 McKinney Street, Suite 1900
Houston, Texas 77010
Attention: Kristhy M. Peguero and Matthew D. Cavanaugh
Email addresses: kpeguero@jw.com, mcavanaugh@jw.com

-and-

Mayer Brown LLP
700 Louisiana Street, Suite 3400
Houston, Texas 77002-3000
Attention: Charles S. Kelley
Email address: ckelley@mayerbrown.com

-and-

Mayer Brown LLP
71 South Wacker Drive
Chicago, Illinois 60606
Attention: Thomas S. Kiriakos and Louis Chiappetta
Email addresses: tkiriakos@mayerbrown.com, lchiappetta@mayerbrown.com

-and-

Mayer Brown LLP
1221 Avenue of the Americas
New York, New York 10020-1001
Attention: Adam Paul and Lucy Kweskin
Email addresses: apaul@mayerbrown.com, lkweskin@mayerbrown.com

After the Effective Date, the Wind Down Debtors and the Wind Down Trustee have authority to send a notice to Entities that, in order to continue to receive documents pursuant to Bankruptcy Rule 2002, such Entity must File a renewed request to receive documents pursuant to Bankruptcy Rule 2002. After the Effective Date, the Wind Down Debtors and the Wind Down Trustee are authorized to limit the list of Entities receiving documents pursuant to Bankruptcy Rule 2002 to those Entities who have Filed such renewed requests.

H. Enforcement of Confirmation Order.

On and after the Effective Date, the Debtors, the Wind Down Debtors, the Wind Down Trustee, the Wind Down Trust, and the Litigation Trust, as applicable, shall be entitled to enforce the terms of the Confirmation Order and the Plan.

I. Term of Injunctions or Stays.

Unless otherwise provided in the Plan or in the Confirmation Order, all injunctions or stays in effect in the Chapter 11 Cases pursuant to sections 105 or 362 of the Bankruptcy Code or any order of the Bankruptcy Court, and extant on the Confirmation Date (excluding any injunctions or stays contained in the Plan or the Confirmation Order) shall remain in full force and effect until the Effective Date. All injunctions or stays contained in the Plan or the Confirmation Order (including the injunction set forth in Article VIII.G of this Plan) shall remain in full force and effect in accordance with their terms.

J. Entire Agreement.

Except as specifically set forth herein, the Plan, the Confirmation Order, and the Plan Supplement supersede all previous and contemporaneous negotiations, promises, covenants, agreements, understandings, and representations made in these Chapter 11 Cases, all of which have become merged and integrated into the Plan.

K. Votes Solicited in Good Faith.

Upon entry of the Confirmation Order, the Debtors will be deemed to have solicited votes on the Plan in good faith and in compliance with section 1125(g) of the Bankruptcy Code, and pursuant to section 1125(e) of the Bankruptcy Code, the Debtors and each of their respective Affiliates, agents, representatives, members, principals, shareholders, officers, directors, managers, employees, advisors, and attorneys will be deemed to have participated in good faith and in compliance with the Bankruptcy Code in the offer, issuance, sale, and purchase of securities offered and sold under the Plan and any previous plan, and, therefore, neither any of such parties or individuals or the Wind Down Debtors will have any liability for the violation of any applicable

law, rule, or regulation governing the solicitation of votes on the Plan or the offer, issuance, sale, or purchase of the securities offered and sold under the Plan and any previous plan.

L. Exhibits.

All exhibits and documents included in the Plan Supplement are incorporated into and are a part of the Plan as if set forth in full in the Plan. After the exhibits and documents are Filed, copies of such exhibits and documents shall be available upon written request to the Debtors' counsel at the address above or by downloading such exhibits and documents from the Debtors' restructuring website at <http://www.donlinrecano.com/clients/gwg> or the Bankruptcy Court's website at www.txs.uscourts.gov.

M. Nonseverability of Plan Provisions.

If, before Confirmation, any term or provision of the Plan is held by the Bankruptcy Court to be invalid, void, or unenforceable, the Bankruptcy Court, at the request of the Debtors, shall have the power to alter and interpret such term or provision to make it valid or enforceable to the maximum extent practicable, consistent with the original purpose of the term or provision held to be invalid, void, or unenforceable, and such term or provision shall then be applicable as altered or interpreted. Notwithstanding any such holding, alteration, or interpretation, the remainder of the terms and provisions of the Plan will remain in full force and effect and will in no way be affected, impaired, or invalidated by such holding, alteration, or interpretation. The Confirmation Order shall constitute a judicial determination and shall provide that each term and provision of the Plan, as it may have been altered or interpreted in accordance with the foregoing, is: (1) valid and enforceable pursuant to its terms; (2) integral to the Plan and may not be deleted or modified without the consent of the Debtors; and (3) nonseverable and mutually dependent.

N. Closing of Chapter 11 Cases.

The Wind Down Trustee shall, promptly after the full administration of the Chapter 11 Cases, File with the Bankruptcy Court all documents required by Bankruptcy Rule 3022 and any applicable order of the Bankruptcy Court to close the Chapter 11 Cases; *provided* that, following the Effective Date, the Wind Down Trustee may seek to close certain of the Chapter 11 Cases that have been fully administered, notwithstanding the fact that the reconciliation of Claims is ongoing.

O. Creditor Default.

An act or omission by a Holder of a Claim or an Interest in contravention of the provisions of this Plan shall be deemed an event of default under this Plan and upon such an event of default, the Wind Down Trust may pursue any appropriate remedies under applicable law.

P. Waiver or Estoppel.

Each Holder of a Claim or an Interest shall be deemed to have waived any right to assert any argument, including the right to argue that its Claim or Interest should be Allowed in a certain amount, in a certain priority, Secured or not subordinated by virtue of an agreement made with the Debtors or their counsel, or any other Entity, if such agreement was not disclosed in the Plan, the Disclosure Statement, or papers Filed with the Bankruptcy Court before the Confirmation Date.

[Remainder of page intentionally left blank.]

Houston, Texas
April 20, 2023

Respectfully Submitted,

/s/ Jeffrey S. Stein

Jeffrey S. Stein as Chief Restructuring Officer,
President, Chief Executive Officer and
Independent Director of GWG Holdings, Inc.

/s/ Kade Baird

Kade Baird, as designated representative of Bank
of Utah, as Indenture Trustee and solely in its
capacity as Chair of the Official Committee of
Bondholders of GWG Holdings, Inc., *et al.*

/s/ Richard S. Schmidt

Richard S. Schmidt, as Restructuring Manager of
L Bond Management, LLC

JACKSON WALKER LLP

Kristhy M. Peguero (TX Bar No. 24102776)
Matthew D. Cavanaugh (TX Bar No. 24062656)
1401 McKinney Street, Suite 1900
Houston, TX 77010
Telephone: (713) 752-4200
Email: kpeguero@jw.com
mcaavanaugh@jw.com

Co-Counsel for the Debtors and Debtors in Possession

MAYER BROWN LLP

Charles S. Kelley (TX Bar No. 11199580)
700 Louisiana Street, Suite 3400
Houston, TX 77002-2730
Telephone: (713) 238-3000
Email: ckelley@mayerbrown.com

-and-

Thomas S. Kiriakos (admitted *pro hac vice*)
Louis S. Chiappetta (admitted *pro hac vice*)
Jamie R. Netznik (admitted *pro hac vice*)
Lisa Holl Chang
Joshua R. Gross (admitted *pro hac vice*)
Jade Edwards
71 S. Wacker Drive
Chicago, IL 60606
Telephone: (312) 782-0600
Email: tkiriakos@mayerbrown.com
lchiappetta@mayerbrown.com
jnetznik@mayerbrown.com
lhollchang@mayerbrown.com
jgross@mayerbrown.com
jmedwards@mayerbrown.com

-and-

Adam C. Paul (admitted *pro hac vice*)
Lucy F. Kweskin (admitted *pro hac vice*)
Ashley Anglade
1221 Avenue of the Americas
New York, NY 10020-1001
Telephone: (212) 506-2500
Email: apaul@mayerbrown.com
lkweskin@mayerbrown.com
aanglade@mayerbrown.com

Counsel for the Debtors and Debtors in Possession

PORTER HEDGES LLP

Eric M. English (TX Bar No. 24062714)
M. Shane Johnson (TX Bar No. 24083263)
1000 Main Street, 36th Floor
Houston, Texas 77002-2764
Telephone: (713) 226-6000
Facsimile: (713) 226-6248
eenglish@porterhedges.com
sjohnson@porterhedges.com

*Counsel to Creditor Proponent, the Official
Committee of Bondholders of GWG Holdings,
Inc., et al.*

**AKIN GUMP STRAUSS HAUER & FELD
LLP**

Lacy M. Lawrence
State Bar No. 24055913; S.D. Tex. No. 995675
2300 N. Field St., Suite 1800
Dallas, TX 75201
Telephone: (214) 969-2800
Facsimile: (214) 969-4343
Email: llawrence@akingump.com

-and-

Michael S. Stamer (admitted *pro hac vice*)
Abid Qureshi (admitted *pro hac vice*)
Jason P. Rubin (admitted *pro hac vice*)
One Bryant Park
New York, New York 10036
Telephone: (212) 872-1000
Facsimile: (212) 872-1002
Email: mstamer@akingump.com
aqureshi@akingump.com
jrubin@akingump.com

-and-

Scott L. Alberino (admitted *pro hac vice*)
Benjamin L. Taylor (admitted *pro hac vice*)
Robert S. Strauss Tower
2001 K Street, N.W.
Washington, DC 20006-1037
Phone: (202) 887-4000
Fax: (202) 887-4288
Email: salberino@akingump.com
taylorb@akingump.com

*Counsel to Creditor Proponent, the Official
Committee of Bondholders of GWG Holdings,
Inc., et al.*

OKIN ADAMS LLP

Matthew S. Okin (TX Bar No. 00784695)
David L. Curry, Jr. (TX Bar No. 24065107)
Edward A. Clarkson, III (TX Bar No. 24059118)
1113 Vine Street, Suite 240
Houston, Texas 77002
Tel: (713) 228-4100
Fax: (346) 247-7158
Email: mokin@okinadams.com
dcurry@okinadams.com
eclarkson@okinadams.com

*Counsel to Creditor Proponent, L Bond
Management, LLC*

**KATTEN MUCHIN ROSENMAN
LLP**

Steven J. Reisman (*pro hac vice*)
Cindi M. Giglio (*pro hac vice*)
Marc B. Roitman (*pro hac vice*)
Jerry L. Hall (*pro hac vice*)
50 Rockefeller Plaza
New York, NY 10020
Telephone: (212) 940-8800
Email: sreisman@katten.com
cgiglio@katten.com
marc.roitman@katten.com
jerry.hall@katten.com

-and-

Daniel Barnowski (*pro hac vice*)
2900 K Street NW, Suite 200
Washington, DC 20007
Telephone: (202) 625-3500
Email: dan.barnowski@katten.com

*Counsel to Jeffrey S. Stein and Anthony
R. Horton, in their capacity as members
of the Investigations Committee and
Special Committee of the Board of
Directors of GWG Holdings, Inc.*

EXHIBIT 3

Solicitation Procedures

**IN THE UNITED STATES BANKRUPTCY COURT
FOR THE SOUTHERN DISTRICT OF TEXAS
HOUSTON DIVISION**

In re:)	
)	Chapter 11
GWG Holdings, Inc., <i>et al.</i> , ¹)	Case No. 22-90032 (MI)
)	
Debtors.)	(Jointly Administered)
)	

SOLICITATION PROCEDURES

On April 21, 2023, the United States Bankruptcy Court for the Southern District of Texas (the “Court”) entered an order [Docket No. 1681²] (the “Disclosure Statement Order”): (a) authorizing the above-captioned debtors and debtors in possession (collectively, the “Debtors”) to solicit votes on the *Debtors’ Second Amended Joint Chapter 11 Plan* [Docket No. 1678] (as may be amended, supplemented, or modified from time to time and including all exhibits and supplements thereto, the “Plan”);³ (b) approving the *Disclosure Statement for the Debtors’ Second Amended Joint Chapter 11 Plan* [Docket No. 1682] (as may be amended, supplemented, or modified from time to time and including all exhibits and supplements thereto, the “Disclosure Statement”); as containing “adequate information” pursuant to section 1125 of the Bankruptcy Code; (c) approving the solicitation and documents to be included in the solicitation packages; (d) approving procedures for soliciting, receiving, and tabulating votes on the Plan (these “Solicitation Procedures”) and for filing objections to the Plan; and (e) scheduling certain dates with respect thereto.

A. The Voting Record Date

The Court has established February 24, 2023 as the record date for determining which other Holders of Classes of Claims and Interests are entitled to vote on the Plan (the “Voting Record Date”).

B. The Voting Deadline

The Court has established **May 31, 2023, at 4:00 p.m. (prevailing Central Time)**, as the voting deadline (the “Voting Deadline”) for the Plan. The Debtors may extend the Voting

¹ The Debtors in these chapter 11 cases, along with the last four digits of each Debtor’s federal tax identification number, are: GWG Holdings, Inc. (2607); GWG Life, LLC (6955); GWG Life USA, LLC (5538) GWG DLP Funding IV, LLC (2598); GWG DLP Funding VI, LLC (6955) and GWG DLP Funding Holdings VI, LLC (6955). The location of Debtor GWG Holdings, Inc.’s principal place of business and the Debtors’ service address is 325 N. St. Paul Street, Suite 2650, Dallas, TX 75201. Further information regarding the Debtors and these chapter 11 cases is available at the website of the Debtors’ claims and noticing agent: <https://donlinrecano.com/gwg>.

² As modified pursuant to the order entered at docket 1692.

³ Capitalized terms used but not otherwise defined herein shall have the meanings ascribed to such terms in the Plan, the Disclosure Statement, or the Disclosure Statement Order, as applicable.

Deadline, in their discretion, without further order of the Court. To be counted as votes to accept or reject the Plan, all ballots (collectively, the “Ballots”) must be properly executed, completed, and delivered in accordance with the instructions provided on or with the Ballot so that they are **actually received**, in any case, no later than the Voting Deadline by the Solicitation Agent. Ballots should be sent to: (i) if by first class mail, to GWG HOLDINGS, INC., ET AL. Balloting Center, c/o Donlin Recano Company, Attn: Voting Department, P.O. Box 199043 Blythebourne Station, Brooklyn, NY 11219; (ii) if by hand delivery or overnight mail, to GWG HOLDINGS, INC., ET AL. Balloting Center, c/o Donlin Recano Company, Attn: Voting Department, 6201 15th Ave, Brooklyn, NY 11219; (iii) if electronically (solely when permissible pursuant to these Solicitation Procedures), via the Solicitation Agent’s online portal by visiting www.DonlinRecano.com/clients/gwg/vote, or (iv) if via email (solely when permissible pursuant to these Solicitation Procedures), sent in a universally viewable file format such as .PDF to GWGVote@donlinrecano.com.

C. Form, Content, and Manner of Notices

1. *The Solicitation Package*

The Solicitation Package shall contain the following:

- (a) these Solicitation Procedures;
- (b) the Ballot;
- (c) the Confirmation Hearing Notice;
- (d) with respect to holders of Bonds, a plain-English summary of the treatment of Bondholder Claims substantially in the form filed as Docket No. 1677 (the “Bondholder Summary”); and
- (e) any additional documents that the Court has ordered to be made available.

2. *Distribution of the Solicitation Packages*

The Solicitation Package will contain URLs for accessing electronic copies of the Plan, Disclosure Statement, and the Disclosure Statement Order. All other contents of the Solicitation Package, including the Ballot, these Solicitation Procedures, the Bondholder Summary and the Confirmation Hearing Notice, will be provided in paper format.

No later than the Solicitation Deadline, the Debtors shall mail, or cause to be mailed, the Solicitation Package to (a) all Holders of Claims in the Voting Classes who are entitled to vote, as described in Section D below, directly or through their respective Nominees, and (b) any Holder who (i) has asserted an Administrative Claim, Priority Tax Claim, or Priority Non-Tax Claim that is subject to an objection filed on or before the Voting Record Date by the Debtors that seeks to classify such Claim as a General Unsecured Claim in the Voting Class (a “Reclassification Objection”), and (ii) would otherwise be entitled to vote in accordance with Section D below. In addition, the Debtors shall serve, or cause to be served, by electronic mail the Confirmation Hearing Notice containing all of the materials in the Solicitation Package (excluding the Ballot) in

electronic format on the U.S. Trustee and all other parties on the Master Service List entitled to receive notice.

For purposes of serving the Solicitation Packages and the Non-Voting Status Notices, the Debtors may rely on the address information for the Voting Classes, Non-Voting Classes, and unclassified Claims as compiled, updated, and maintained by the Solicitation Agent as of the Voting Record Date. The Debtors and the Solicitation Agent may, but are not required to, conduct any additional research for updated addresses based on undeliverable Solicitation Packages (including Ballots) or Non-Voting Status Notices.

To avoid duplication and reduce expenses, the Debtors will use commercially reasonable efforts to ensure that any Holder of a Claim or Interest entitled to vote on the Plan receives no more than one Solicitation Package (and, therefore, one Ballot) and is only entitled to submit one Ballot for each specific Class of such Claim(s) as against any Debtor.

3. Non-Voting Status Notices for Unimpaired Classes and Parties Otherwise Not Entitled to Vote.

Certain Holders of Claims that are not classified in accordance with section 1123(a)(1) of the Bankruptcy Code, or who are not entitled to vote because they are Unimpaired or otherwise presumed to accept the Plan under section 1126(f) of the Bankruptcy Code, will receive only the *Non-Voting Status Notice to Holders of Unclassified Claims and Unimpaired Claims Conclusively Presumed to Accept the Plan*, substantially in the form attached as Exhibit 4A to the Disclosure Statement Order. Certain Holders of Claims or Interests who are not entitled to vote because their Claims or Interests are disputed will receive the *Notice of Non-Voting Status to Holders of Disputed Claims or Interests*, substantially in the form attached as Exhibit 4B to the Disclosure Statement Order. Such notice will instruct these Holders as to how they may obtain copies of the documents contained in the Solicitation Package (excluding Ballots).

4. Notices in Respect of Assumed Executory Contracts and Unexpired Leases

Counterparties to Executory Contracts and Unexpired Leases that receive an Assumption Notice may file an objection to the Debtors' proposed assumption and/or cure amount, if applicable. Such objections must be filed with the Court (contemporaneously with a proof of service) and served upon the applicable notice parties (as set forth in the Assumption Notice) within 30 calendar days after service thereof. For the avoidance of doubt, counterparties receiving an Assumption Notice will be deemed unimpaired and therefore will not be entitled to vote to accept or reject the Plan.

D. Voting and General Tabulation Procedures

1. Holders of Claims Entitled to Vote

Only the following Holders of Claims and Interests in the Voting Classes, including any Claim that is subject to a pending Reclassification Objection,⁴ shall be entitled to vote with regard to such Claims or Interests:

- (a) With respect to Class 3 Bond Claims (other than Claims held by the Indenture Trustee), Solicitation Packages, including Ballots, will be distributed solely based upon (i) in the case of direct Holders of such Claims, the individualized notices provided pursuant to the Bondholder Claim Procedures Order, subject to the receipt by the Debtors or the Solicitation Agent of updated contact information from any such Holders since the time that such individualized notices were sent; *provided* that LBM shall be deemed to have voted to accept the Plan with respect to the LBM L Bond Claims; and (ii) in the case of Beneficial Holders of such Claims and their Nominees, SPRs obtained as of the Voting Record Date.
- (b) With respect to Class 8, 9, and 10 Interests, Solicitation Packages, including Ballots, will be distributed solely based upon (i) in the case of direct Holders of such Interests, the Debtors' registers of equity security interests as of the Voting Record Date, and (ii) in the case of Beneficial Holders of such Interests and their Nominees, SPRs obtained as of the Voting Record Date.
- (c) Other Holders of Claims who, on or before the Voting Record Date, have timely filed a Proof of Claim that (i) has not been disallowed, disqualified, withdrawn, or superseded prior to such Voting Record Date, and (ii) subject to further Order, is not the subject of a pending objection; *provided* that a Holder of a Claim that is the subject of a pending objection on a "reduce and allow" basis shall receive a Solicitation Package and be entitled to vote such Claim in the reduced amount contained in such objection except as set forth herein;
- (d) Holders of Claims that are listed in the Schedules; *provided* that Claims that are scheduled as contingent, unliquidated, or disputed (excluding such scheduled disputed, contingent, or unliquidated Claims that have been paid or superseded by a timely filed Proof of Claim) shall be disallowed for voting purposes;
- (e) Holders of Claims that arise (i) pursuant to an agreement or settlement with the Debtors, as reflected in a document filed with the Court, or (ii) in an order entered by the Court, in each case regardless of whether a Proof of Claim has been filed; and

⁴ In addition to complying with the other requirements herein, votes submitted on account of a Claim subject to a Reclassification Objection shall only be counted if the Court enters an order approving the reclassification of such Claim on or before the Voting Deadline.

- (f) the assignee of any Claim or Interest that was transferred on or before the Voting Record Date by any Entity described in subparagraphs (a) through (e) above; *provided* that (other than with respect to a Beneficial Holder of any such Claim or Interest) such transfer or assignment has been fully effectuated pursuant to the procedures set forth in Bankruptcy Rule 3001(e) and such transfer is reflected on the Claims Register on the Voting Record Date.

2. *Establishing Claim Amounts for Voting Purposes*

Class 3 (Bond Claims): The voting amounts for Class 3 (Bond Claims) will be (i) with respect to direct-held Class 3 Bond Claims, the greater of (a) the principal amount identified on the Notice to Direct-Held Bondholders Regarding Bondholder Claims Bar Date with respect to each Holder thereof sent pursuant to the Bondholder Claim Procedures Order; and (b) if a Holder of a Class 3 Bond Claim has filed a Proof of Claim regarding the amount of its respective Class 3 Bond Claim, the principal amount identified on such Proof of Claim, only to the extent that such Proof of Claim is not the subject of a pending objection as of the Claim Solicitation Objection Deadline or has not otherwise been disallowed; and (ii) with respect to indirect-held Bond Claims, the principal amounts of Bonds set forth on Schedule 1 to the Notice to Indirect-Held Bondholders Regarding Bondholder Claims Bar Date sent pursuant to the Bondholder Claim Procedures Order that, as to each Nominee, is based upon SPRs as of the Voting Record Date for each such Nominee.

Class 4(a) (General Unsecured Claims): The amount of Class 4(a) (General Unsecured Claims) for voting purposes only will be established based on the amount of the applicable positions held by such Class 4(a) Claim Holder, as of the Voting Record Date, as evidenced by (a) the Schedules and (b) the Claims Register; *provided* that, subject to further Order, the amount of any such Claim subject to a timely-filed pending objection shall be reduced to \$0 solely for voting purposes and shall not be entitled to vote such Claim. If a Proof of Claim is amended, the last filed claim shall be subject to these rules and will supersede any earlier filed claim, and any earlier filed claim will be disallowed for voting purposes. For the avoidance of doubt, any Claim for damages arising from the purchase of Bonds is treated as a Class 4(a) General Unsecured Claim under the Plan and any Holder of any such Claim who timely filed a Proof of Claim with respect thereto shall be entitled to vote such Claim unless such Claim is withdrawn or disallowed prior to the Voting Deadline or, subject to further Order, is subject to a pending objection as of the Claim Solicitation Objection Deadline.

Class 8, 9, and 10 Interests: The voting amounts for Class 8, 9, and 10 Interests will be (i) with respect to such Interests where registered in the name of the Holder thereof directly with the Debtors, the number of shares of such Interests reflected in the Debtors' registers of equity security interests as of the Voting Record Date; (ii) with respect to such Interests held by a Nominee, the number of shares of such Interests reflected in the Debtors' registers of equity security interest as of the Voting Record Date that, as to each Nominee, is based upon SPRs obtained with a record date of the Voting Record Date for each such Nominee; and (iii) to the extent a Holder of Class 8, 9, or 10 Interests has asserted in a timely filed Proof of Claim or proof of interest a Claim for damages arising from the purchase of such Interests, such Holder shall be entitled to vote such Claim as a single share of Class 10 Interests unless such Claim is withdrawn

or disallowed prior to the Voting Deadline or is subject to a pending objection as of the Claim Solicitation Objection Deadline.

Filed and Scheduled Claims: The Claim and Interest amounts established herein shall control for voting purposes only and shall not constitute the Allowed amount of any Claim or Interest. Moreover, any amounts filled in on Ballots by the Debtors through the Solicitation Agent, as applicable, are not binding for purposes of allowance and distribution. In tabulating votes with respect to Class 4(a) General Unsecured Claims, the following hierarchy shall be used to determine the amount of the Claim associated with each claimant's vote:

- (a) the Claim amount Allowed by order of the Court;
- (b) the Claim amount (i) settled or agreed upon by the Debtors, as reflected in a document filed with the Court, or (ii) set forth in an order of the Court;
- (c) the Claim amount contained in a Proof of Claim that has been timely filed by the applicable Claims Bar Date (or deemed timely filed by the Court under applicable law) and not disallowed prior to the Voting Deadline, except for any amounts asserted on account of any interest accrued after the Initial Petition Date;
- (d) if a Claim, for which a Proof of Claim has been timely filed, is in a wholly unliquidated amount, and such Claim has not been allowed, such Claim shall be temporarily allowed for voting purposes only, and not for purposes of allowance or distribution, at \$1.00;
- (e) if a Claim, for which a Proof of Claim was timely filed, is filed as unliquidated in part, such Claim is temporarily allowed in the amount that is liquidated for voting purposes only, and not for purposes of allowance or distribution;
- (f) the Claim amount listed in the Schedules (unless such Claim has been superseded by a timely filed Proof of Claim); *provided* that such Claim is not scheduled as contingent, disputed, or unliquidated and/or has not been paid;
- (g) Proofs of Claim filed for \$0.00 are not entitled to vote;
- (h) notwithstanding anything herein, any creditor who has filed or purchased multiple Claims or Interests within the same Voting Class shall, to the extent practicable, be provided with only one Solicitation Package and one Ballot for voting a single Claim or interest in such Class, regardless of whether the Debtors have objected to such duplicate Claims or Interests;
- (i) if a Proof of Claim has been amended by a later Proof of Claim that is filed on or prior to the Voting Record Date, the later-filed amending Proof of Claim shall be entitled to vote in a manner consistent with these tabulation rules, and the earlier-filed Proof of Claim shall be disallowed for voting

purposes, regardless of whether the Debtors have objected to such amended claim. Except as otherwise ordered by the Court, any amendments to Proofs of Claim after the Voting Record Date shall not be considered for purposes of these tabulation rules; and

- (j) in the absence of any of the foregoing, such Claim shall be disallowed for voting purposes.

3. *Voting and Ballot Tabulation Procedures*

The following voting procedures and standard assumptions shall be used in tabulating Ballots, subject to the Debtors' right, in consultation with the Bondholder Committee, to waive any of the below specified requirements for completion and submission of Ballots so long as such requirement is not otherwise required by the Bankruptcy Code, Bankruptcy Rules, or Bankruptcy Local Rules:

- (a) except as otherwise provided herein, unless the Ballot being furnished is timely submitted to the Solicitation Agent on or prior to the Voting Deadline (as the same may be extended by the Debtors), the Ballot will not count;
- (b) the Debtors will file a voting report (the "Voting Report") with the Court by no later than June 12, 2023. The Voting Report shall, among other things, delineate every Ballot that does not conform to the voting instructions or that contains any form of irregularity including, but not limited to, those Ballots that are late or (in whole or in material part) illegible, unidentifiable, lacking signatures, or lacking necessary information, received via facsimile, or damaged (in each case, an "Irregular Ballot"). The Voting Report shall indicate the Debtors' intentions with regard to each Irregular Ballot;
- (c) the method of delivery of Ballots to be sent to the Solicitation Agent is at the election and risk of each Holder. Except as otherwise provided, a Ballot will be deemed delivered only when the Solicitation Agent actually receives the properly executed Ballot;
- (d) no Ballot should be sent to the Debtors, the Debtors' agents (other than the Solicitation Agent), or the Debtors' financial or legal advisors, and if so sent, such Ballot will not be counted; *provided, however*, that if the Debtors, the Debtors' agents, or the Debtors' financial or legal advisors receive any Ballot, such Entity shall make a good faith effort to forward such Ballot to the Solicitation Agent prior to the Voting Deadline;
- (e) if multiple Ballots are received from the same Holder with respect to the same Claim prior to the Voting Deadline, the last properly executed Ballot timely received will be deemed to reflect that voter's intent and will supersede and revoke any prior received Ballot;
- (f) Holders must vote all of their Claims, regardless of whether such Claims are asserted against one or multiple Debtors, either to accept or reject the

Plan and may not split any votes. Accordingly, a Ballot (other than a Master Ballot) that partially rejects and partially accepts the Plan will not be counted. Further, to the extent there are multiple Claims within the same Class, the applicable Debtor will aggregate the Claims of any particular Holder within a Class for the purpose of counting votes;

- (g) Omitted;
- (h) all Ballots submitted on account of Class 3 Bond Claims shall be deemed to be Ballots with respect to both GWGH and GWG Life, LLC;
- (i) a person signing a Ballot in its capacity as a trustee, executor, administrator, guardian, attorney in fact, officer of a corporation, or otherwise acting in a fiduciary or representative capacity of a Holder of Claims or Interests must indicate such capacity when signing; *provided, however*, that no Person shall mark a vote to accept or reject the Plan or complete Item 2 of any Ballot unless expressly authorized in writing by a Holder of Claims or Interests to vote on a chapter 11 plan on such Holder's behalf;
- (j) the Debtors may waive any defects or irregularities as to any particular Irregular Ballot at any time, either before or after the close of voting, and any such waivers will be documented in the Voting Report or a supplemental voting report, as applicable;
- (k) neither the Debtors, nor any other Entity, will be under any duty to provide notification of defects or irregularities with respect to delivered Ballots to any party other than as provided in the Voting Report, nor will any of them incur any liability for failure to provide such notification; *provided, however*, notwithstanding the foregoing, the Debtors shall inform the Bondholder Committee professionals of any defects or irregularities with respect to delivered Ballots as soon as reasonably practicable upon receipt of Class 3 (Bond Claims) Ballots and the Bondholder Committee is permitted to inform such voter of the defect and the process for correcting their Ballot; *provided, further*, that the Debtors may provide claimants with a reasonable opportunity to cure such defects up until the Voting Deadline;
- (l) unless waived or as ordered by the Court and in accordance with the foregoing, any defects or irregularities in connection with deliveries of Ballots must be cured by the Holder of Claims prior to the Voting Deadline or such Ballots will not be counted;
- (m) in the event a designation of lack of good faith is requested by a party in interest under section 1126(e) of the Bankruptcy Code, the Court will determine whether any vote to accept and/or reject the Plan cast with respect to that Claim or Interest will be counted for purposes of determining whether the Plan has been accepted and/or rejected;

- (n) subject to any order of the Court, the Debtors reserve the right to reject any and all Ballots not in proper form, the acceptance of which, in the opinion of the Debtors, would not be in accordance with the provisions of the Bankruptcy Code or the Bankruptcy Rules; *provided* that any such rejections will be documented in the Voting Report;
- (o) if a Claim has been estimated or a Claim or Interest has otherwise been Allowed only for voting purposes by order of the Court, such Claim or Interest shall be temporarily Allowed in the amount so estimated or Allowed by the Court for voting purposes only, and not for purposes of allowance or distribution;
- (p) if an objection to a Claim or Interest is filed on or before the Claim Solicitation Objection Deadline, subject to further Order, such Claim or Interest shall be treated in accordance with the procedures set forth herein, and the objected-to portion of any such Claim or Interest shall not be included in the tabulation of votes to accept or reject the Plan;
- (q) the following Ballots shall not be counted in determining the acceptance or rejection of the Plan: (i) any Ballot that is illegible or contains insufficient information to permit the identification of the Holder of such Claim; (ii) any Ballot cast by any Entity that does not hold a Claim or Interest in a Voting Class; (iii) any Ballot cast for a Claim listed on the Debtors' schedules as unliquidated, contingent, or disputed for which no Proof of Claim was timely filed by the Voting Record Date (unless the applicable bar date has not yet passed, in which case such Claim shall be entitled to vote in the amount of \$1.00); (iv) any unsigned Ballot or Ballot lacking an original signature (for the avoidance of doubt, a Ballot cast via the online balloting portal will be deemed to contain an original signature); (v) any Ballot not marked to accept or reject the Plan or marked both to accept and reject the Plan; and (vi) any Ballot submitted by any Entity not entitled to vote pursuant to the procedures described herein;
- (r) after the Voting Deadline, no Ballot may be withdrawn or modified without Court approval;
- (s) Omitted;
- (t) where any portion of a single Claim or Interest has been transferred to a transferee, all Holders of any portion of such single Claim or Interest will be (i) treated as a single creditor for purposes of the numerosity requirements in section 1126(c) of the Bankruptcy Code (and for the other voting and solicitation procedures set forth herein), and (ii) required to vote every portion of such Claim or Interest collectively to accept or reject the Plan. In the event that (i) a Ballot, (ii) a group of Ballots within a Voting Class received from a single creditor or interest-holder, or (iii) a group of Ballots received from the various Holders of multiple portions of a single

Claim or Interest partially reject and partially accept the Plan, such Ballots shall not be counted; and

- (u) for purposes of determining satisfaction of the numerosity requirement of section 1126(c) of the Bankruptcy Code, separate Claims or Interests held by a single creditor or interest-holder in a particular Class will be aggregated and treated as if such creditor held one Claim or Interest in such Class, and all votes related to such Claim or Interest will be treated as a single vote to accept or reject the Plan; *provided* that if separate affiliated entities hold Claims or Interests in a particular Class, these Claims or Interests will not be aggregated and will not be treated as if such creditor or interest-holder held one Claim or Interest in such Class, and the vote of each affiliated entity will be counted separately as a vote to accept or reject the Plan.

4. *Master Ballot Solicitation, Voting and Tabulation Procedures*

In addition to the foregoing generally applicable voting and ballot tabulation procedures, the following procedures shall apply to Beneficial Holders of Claims and Interests in Classes 3, 8, 9, and 10 who hold and will vote their position through a Nominee:

- (i) the Solicitation Agent shall distribute or cause to be distributed to the Nominees (i) the appropriate number of Solicitation Packages for each Beneficial Holder represented by the Nominee as of the Voting Record Date, which will contain copies of Ballots for each beneficial holder (a “Beneficial Holder Ballot”) and (ii) a master ballot (the “Master Ballot”);
- (ii) each Nominee shall immediately, and in any event within three Business Days after its receipt of the Solicitation Packages to the extent reasonably practicable, commence the solicitation of votes from its Beneficial Holder clients through one of the following two methods:
 - (A) distribute to each beneficial holder the Solicitation Packages along with a Beneficial Holder Ballot, voting information form (“VIF”), and/or other customary communication used to collect voting information from its Beneficial Holder clients along with instructions to the Beneficial Holder to return its vote to the Nominee in a timely fashion; *provided, however*, that Nominees shall not mark a vote to accept or reject the Plan or complete Item 2 of the Beneficial Holder Ballot prior to distribution of the Solicitation Packages to Beneficial Holders unless expressly authorized in writing by such Beneficial Holder to vote on a chapter 11 plan on such Beneficial Holder’s behalf; *provided, further*, that any Nominee that elects to distribute a VIF and/or other customary communication used to collect voting information shall meet all applicable standards to receive informed consent from its Beneficial Holders; *provided, further*, that Nominees shall clearly communicate in such materials to Beneficial Holders the timing

requirements for their Beneficial Holder Ballots to be included on the Master Ballot prior to the Voting Deadline; or

- (B) distribute to each Beneficial Holder the Solicitation Package along with a “pre-validated” Ballot (a “Pre-Validated Beneficial Holder Ballot”) signed by the Nominee and including the Beneficial Holder’s account number, the amount of Claims held by the Nominee for such Beneficial Holder, and a medallion guarantee stamp certifying the Beneficial Holder’s position in their asserted Claims as of the Voting Record Date with instructions to the Beneficial Holder to return its Pre-Validated Beneficial Holder Ballot to the Solicitation Agent in a timely fashion; *provided, however,* that such Nominee providing “pre-validated” Ballots shall not mark a vote to accept or reject the Plan or complete Item 2 of the Beneficial Holder Ballot unless such Nominee is expressly authorized in writing by the Beneficial Holder to vote on a chapter 11 plan on such Beneficial Holder’s behalf;
- (iii) each Nominee shall compile and validate the votes and other relevant information of all such Beneficial Holders on the Master Ballot and transmit the Master Ballot to the Solicitation Agent on or before the Voting Deadline;
- (iv) Nominees that submit Master Ballots must keep the original Beneficial Holder Ballots, VIFs, or other communication used by the Beneficial Holder to transmit its vote for a period of one year after the Effective Date of the Plan;
- (v) Nominees that pre-validate Beneficial Holder Ballots must keep a list of Beneficial Holders for whom they pre-validated a Ballot, along with copies of the Pre-Validated Beneficial Holder Ballots for a period of one year after the Effective Date of the Plan;
- (vi) the Solicitation Agent will not count votes of Beneficial Holders unless and until they are included on a valid and timely Master Ballot or a valid and timely Pre-Validated Beneficial Holder Ballot;
- (vii) if a Beneficial Holder holds Claims through more than one Nominee or through multiple accounts, such Beneficial Holder may receive more than one Beneficial Holder Ballot or Pre-Validated Beneficial Holder Ballot, and each such Beneficial Holder must vote consistently and execute a separate Beneficial Holder Ballot or Pre-Validated Beneficial Holder Ballot for each Claim that it holds through any Nominee and must return each such Beneficial Holder Ballot to the appropriate Nominee or each such Pre-Validated Beneficial Holder Ballot to the Solicitation Agent;

- (viii) votes cast by Beneficial Holders through Nominees will be applied to the applicable positions held by such Nominees in the applicable Voting Class, as of the Voting Record Date, as evidenced by the record and depository listings. Votes submitted by a Nominee pursuant to a Master Ballot will not be counted in excess of the amount of such Claims held by such Nominee as of the Voting Record Date;
- (ix) if conflicting votes or “over-votes” are submitted by a Nominee pursuant to a Master Ballot, the Solicitation Agent will use reasonable efforts to reconcile discrepancies with the Nominees; *provided, however*, that the Debtors shall provide prompt notice of any such discrepancies to the Bondholder Committee. If over-votes on a Master Ballot are not reconciled prior to the preparation of the Voting Report, the Debtors shall apply the votes to accept and to reject the Plan in the same proportion as the votes to accept and to reject the Plan submitted on the Master Ballot that contained the over-vote, but only to the extent of the Nominee’s position in the applicable Voting Class;
- (x) a single Nominee may complete and deliver to the Solicitation Agent multiple non-duplicative Master Ballots. Votes reflected on multiple Master Ballots will be counted, except to the extent that they are duplicative of other Master Ballots. If two or more Master Ballots submitted by a single Nominee are inconsistent, the latest received valid Master Ballot received prior to the Voting Deadline will, to the extent of such inconsistency, supersede and revoke any prior received Master Ballot. Likewise, if a Beneficial Holder submits more than one Beneficial Holder Ballot to its Nominee or more than one Pre-Validated Beneficial Holder Ballot to the Solicitation Agent, (i) the latest received Beneficial Holder Ballot or Pre-Validated Beneficial Holder Ballot received before the submission deadline imposed by the Nominee or the Voting Deadline, respectively, shall be deemed to supersede any prior Beneficial Holder Ballot or Pre-Validated Beneficial Holder Ballot, as applicable, submitted by the Beneficial Holder, and (ii) the Nominee shall complete the Master Ballot accordingly;
- (xi) the Debtors are authorized, but not directed, upon written request, to reimburse Nominees for reasonable and documented customary mailing and handling expenses incurred by them in forwarding the Beneficial Holder Ballot and other enclosed materials to the Beneficial Holders for which they are the Nominee. No fees or commissions or other remuneration will be payable to any Nominee or other person for soliciting votes from its Beneficial Holder clients with respect to the Plan.

E. Amendments to the Plan and Solicitation Procedures

The Debtors reserve the right to make non-substantive or immaterial changes to the Plan, (including, for the avoidance of doubt, the Plan Supplement), Disclosure Statement, Ballots, Confirmation Hearing Notice, and related documents without further order of the Court, including,

without limitation, changes to correct typographical and grammatical errors, if any, and to make conforming changes among the Plan, Disclosure Statement, and any other materials, in the Solicitation Package before their distribution.

Exhibit 3A

**Form of Ballot
Class 3 Direct-Held Bond Claims**

DONLIN, RECANO & COMPANY, INC., RE: GWG HOLDINGS, INC., ET AL., P.O. BOX 199043, BLYTHEBOURNE STATION, BROOKLYN, NY 11219; (III) CALLING 1 (888) 508-2507 (U.S. TOLL FREE); OR (IV) EMAILING GWGINFO@DONLINRECANO.COM; OR (B) FOR A FEE VIA PACER AT [HTTPS://ECF.TXSB.USCOURTS.GOV/](https://ecf.txsb.uscourts.gov/).

Solicitation Overview

The above-captioned debtors and debtors in possession (collectively, the “Debtors”), are soliciting votes with respect to the Plan as set forth in the *Disclosure Statement for the Debtors’ Second Amended Joint Chapter 11 Plan* [Docket No. 1682] (as may be amended, supplemented, or modified, the “Disclosure Statement”) and the *Debtors’ Second Amended Joint Chapter 11 Plan* [Docket No. 1678] (as may be amended, supplemented, or modified, the “Plan”).² The Bankruptcy Court for the Southern District of Texas (the “Court”) has approved the Disclosure Statement as containing adequate information pursuant to section 1125 of the Bankruptcy Code, by entry of an order on April 21, 2023 [Docket No. 1681³] (the “Disclosure Statement Order”). Court approval of the Disclosure Statement does not indicate approval of the Plan by the Court.

Your rights are described in the Plan, the Disclosure Statement, and the related materials. If you would like paper copies of the Plan, Disclosure Statement, and other Solicitation Materials, or if you need to obtain additional Solicitation Packages, you may obtain them (a) at no charge from Donlin Recano & Company, Inc. (the “Solicitation Agent”) by: (i) accessing the Debtors’ restructuring website at <https://www.donlinrecano.com/Clients/gwg/Index>; (ii) calling 1 (888) 508-2507 (U.S. toll-free) or (iii) emailing gwginfo@donlinrecano.com; or (b) for a fee via PACER at <https://ecf.txsb.uscourts.gov/>.

You are receiving this ballot (the “Ballot”) because records indicate that, as of February 24, 2023 (the “Voting Record Date”), you are the direct Holder of an Allowed Class 3 Bond Claim, or an assignee or transferee thereof. Accordingly, you have a right to vote to accept or reject the Plan. As set forth in the Disclosure Statement, the Debtors, the Bondholder Committee, LBM, and the Ad Hoc Committee of Broker/Dealers recommend that you vote to **ACCEPT** the Plan.

If the Plan is confirmed by the Court, it will be binding on you regardless of whether or not you vote or whether you vote to accept or reject the Plan. To have your vote counted, you must complete, sign, and return this Ballot so that it is received by the Solicitation Agent no later than the Voting Deadline.

This Ballot may not be used for any purpose other than for casting votes to accept or reject the Plan and making certain certifications with respect to the Plan. If you believe you have received this Ballot in error, or if you believe you have received the wrong ballot, please contact the Solicitation Agent immediately at the address, telephone number, or email address set forth above.

² Capitalized terms used but not otherwise defined herein shall have the meanings ascribed to such terms in the Plan, the Disclosure Statement, or the Disclosure Statement Order, as applicable.

³ As modified pursuant to the order entered at docket 1692.

The above information is a simplified summary of certain aspects of the Plan for informational purposes only and should not be relied upon. *You should carefully and thoroughly review the Disclosure Statement and Plan before you vote to accept or reject the Plan. You may wish to seek legal advice concerning the Plan and classification and treatment of your Claim under the Plan.*

Submitting Your Ballot

You should review the Plan and the Disclosure Statement and the instructions contained herein before you vote. You may wish to seek legal advice concerning the Plan and the Plan's classification and treatment of your Claim. **THE DEBTORS AND THE SOLICITATION AGENT ARE NOT AUTHORIZED TO PROVIDE, AND WILL NOT PROVIDE, LEGAL ADVICE.**

PLEASE SUBMIT YOUR BALLOT BY *ONLY ONE* OF THE FOLLOWING METHODS:

Via Electronic Mail. Complete, sign, and date this Ballot and email a scanned copy of the ballot in a universally viewable file format such as .PDF to GWGVote@donlinrecano.com.

OR

Via Paper Ballot. Complete, sign, and date this Ballot and return it (with an original signature) promptly in the envelope provided or:

By First Class Mail to:

**GWG HOLDINGS, INC., ET AL. Balloting Center
c/o Donlin Recano Company
Attn: Voting Department
P.O. Box 199043 Blythebourne Station
Brooklyn, NY 11219**

By Hand Delivery or Overnight Mail to:

**GWG HOLDINGS, INC., ET AL. Balloting Center
c/o Donlin Recano Company
Attn: Voting Department
6201 15th Ave
Brooklyn, NY 11219**

OR

Via eBallot Portal:

Ballots may be submitted via an electronic Ballot through the Voting Agent's on-line electronic Ballot submission portal at www.DonlinRecano.com/clients/gwg/vote (the "eBallot Portal") by no later than the Voting Deadline. Any failure to follow the voting instructions included with the Ballot may disqualify your Ballot and your vote.

In order to submit a Ballot through the eBallot Portal, you must use the Unique eBallot ID# assigned to your claim. Please complete and submit an electronic Ballot for each eBallot ID# you receive.

UNIQUE E-BALLOT IDENTIFICATION _____

Each eBallot ID# is to be used solely for voting only those Claims described in Item 1 of your electronic Ballot. Please complete and submit an electronic Ballot for each eBallot ID# you receive, as applicable.

Creditors who cast a Ballot using the E-Ballot Portal should NOT also submit a paper Ballot.

Item 1. Amount of Claim.⁴

The undersigned hereby certifies that as of the Voting Record Date, the books and records of the Debtors reflect that the undersigned was the Holder of Direct-Held Bondholder Claims in the following principal amount (insert amount in box below):

\$ _____

The above amount may not be the same as the amount you included in a filed Proof of Claim, and the above amount excludes accrued interest solely for voting tabulation purposes. The submission of this Ballot with respect to the above amount is without prejudice to the resolution of the allowance of your Claim, which will ultimately include principal on the Bonds plus accrued unpaid interest through April 20, 2022.

Item 2. Vote on Plan.

The direct Holder of the Bond Claims set forth in Item 1 votes to (please check only one):

<input type="checkbox"/> <u>ACCEPT</u> (vote FOR) the Plan
<input type="checkbox"/> <u>REJECT</u> (vote AGAINST) the Plan

Item 3. Important information regarding the release, exculpation, and injunction provisions in the Plan.⁵

Article VIII.C of the Plan contains the following release (the “**Release**”):

PURSUANT TO SECTION 1123(B) OF THE BANKRUPTCY CODE, IN EXCHANGE FOR GOOD AND VALUABLE CONSIDERATION, THE ADEQUACY OF WHICH IS HEREBY CONFIRMED, ON AND AFTER THE EFFECTIVE DATE, EACH RELEASED PARTY (BUT NO NON-RELEASED PARTY) IS, AND IS DEEMED HEREBY TO BE, FULLY, CONCLUSIVELY, ABSOLUTELY, UNCONDITIONALLY, IRREVOCABLY, AND FOREVER RELEASED AND DISCHARGED BY THE DEBTORS, THE WIND DOWN DEBTORS, AND THEIR ESTATES, AND ANY PERSON SEEKING TO EXERCISE THE RIGHTS OF THE DEBTORS OR THEIR ESTATES, INCLUDING ANY SUCCESSORS TO THE DEBTORS OR ANY ESTATES REPRESENTATIVES APPOINTED OR SELECTED PURSUANT TO SECTION 1123(B)(3) OF THE

⁴ For voting purposes only, subject to tabulation rules.

⁵ The Plan provisions referenced herein are for summary purposes only and do not include all provisions of the Plan that may affect your rights. If there is any inconsistency between the provisions set forth herein and the Plan, the Plan governs. You should read the Plan before completing this Ballot.

BANKRUPTCY CODE, IN EACH CASE ON BEHALF OF THEMSELVES AND THEIR RESPECTIVE SUCCESSORS, ASSIGNS, AND REPRESENTATIVES, AND ANY AND ALL OTHER ENTITIES WHO MAY PURPORT TO ASSERT ANY CAUSE OF ACTION, DIRECTLY OR DERIVATIVELY, BY, THROUGH OR FOR THE DEBTORS OR THEIR ESTATES, FROM ANY AND ALL CLAIMS AND CAUSES OF ACTION, WHETHER KNOWN OR UNKNOWN, INCLUDING ANY DERIVATIVE CLAIMS, ASSERTED OR ASSERTABLE ON BEHALF OF THE DEBTORS, WHETHER KNOWN OR UNKNOWN, FORESEEN OR UNFORESEEN, MATURED OR UNMATURED, EXISTING OR HEREAFTER ARISING, CONTINGENT OR NON-CONTINGENT, IN LAW, EQUITY, CONTRACT, TORT OR OTHERWISE, EXCEPT FOR ANY CLAIMS RELATED TO ANY ACT OR OMISSION THAT IS DETERMINED IN A FINAL ORDER TO HAVE CONSTITUTED ACTUAL FRAUD, WILLFUL MISCONDUCT, INTENTIONAL BREACH OF FIDUCIARY DUTY, OR GROSS NEGLIGENCE, THAT THE DEBTORS, THE WIND DOWN DEBTORS, OR THEIR ESTATES, INCLUDING ANY SUCCESSORS TO THE DEBTORS OR ANY ESTATES REPRESENTATIVE APPOINTED OR SELECTED PURSUANT TO SECTION 1123(B) OF THE BANKRUPTCY CODE, WOULD HAVE BEEN LEGALLY ENTITLED TO ASSERT IN THEIR OWN RIGHT (WHETHER INDIVIDUALLY OR COLLECTIVELY) OR ON BEHALF OF THE HOLDER OF ANY CLAIM OR INTEREST IN, A DEBTOR OR OTHER ENTITY, OR THAT ANY HOLDER OF ANY CLAIM AGAINST, OR INTEREST IN, A DEBTOR OR OTHER ENTITY COULD HAVE ASSERTED ON BEHALF OF THE DEBTORS, BASED ON OR RELATING TO, OR IN ANY MANNER ARISING FROM, IN WHOLE OR IN PART, THE DEBTORS (INCLUDING THE CAPITAL STRUCTURE, MANAGEMENT, OWNERSHIP OR OPERATION THEREOF), THE BUSINESS OR CONTRACTUAL ARRANGEMENT BETWEEN THE DEBTORS AND ANY RELEASED PARTY, ANY SECURITIES ISSUED BY THE DEBTORS AND THE OWNERSHIP THEREOF, THE ASSERTION OR ENFORCEMENT OF RIGHTS AND REMEDIES AGAINST THE DEBTORS, THE DEBTORS' IN- OR OUT-OF-COURT RESTRUCTURING EFFORTS, ANY AVOIDANCE ACTIONS (BUT EXCLUDING AVOIDANCE ACTIONS BROUGHT AS COUNTERCLAIMS OR DEFENSES TO CLAIMS ASSERTED AGAINST THE DEBTORS), INTERCOMPANY TRANSACTIONS BETWEEN OR AMONG A DEBTOR AND ANOTHER DEBTOR, THE FORMULATION, PREPARATION, DISSEMINATION, NEGOTIATION, OR FILING OF THE DISCLOSURE STATEMENT, THE PLAN (INCLUDING, FOR THE AVOIDANCE OF DOUBT, THE PLAN SUPPLEMENT), THE VIDA DIP FINANCING FACILITY, THE VIDA EXIT FINANCING FACILITY, OR ANY WIND DOWN TRANSACTION, CONTRACT, INSTRUMENT, RELEASE, OR OTHER AGREEMENT OR DOCUMENT (INCLUDING ANY LEGAL OPINION REQUESTED BY ANY ENTITY REGARDING ANY TRANSACTION, CONTRACT, INSTRUMENT, DOCUMENT OR OTHER AGREEMENT CONTEMPLATED BY THE PLAN OR THE RELIANCE BY ANY RELEASED PARTY ON THE PLAN OR THE CONFIRMATION ORDER IN LIEU OF SUCH LEGAL OPINION) CREATED OR ENTERED INTO IN CONNECTION WITH THE DISCLOSURE STATEMENT, THE VIDA EXIT FINANCING FACILITY DOCUMENTS, THE PLAN, OR THE PLAN SUPPLEMENT, BEFORE OR DURING THE CHAPTER 11 CASES, THE CHAPTER 11 CASES, THE FILING OF THE CHAPTER 11 CASES, THE PURSUIT OF CONFIRMATION, THE ADMINISTRATION AND IMPLEMENTATION OF THE PLAN, INCLUDING THE

ISSUANCE OR DISTRIBUTION OF SECURITIES PURSUANT TO THE PLAN, OR THE DISTRIBUTION OF PROPERTY UNDER THE PLAN, OR UPON ANY RELATED ACT OR OMISSION, TRANSACTION, AGREEMENT, EVENT, OR OTHER OCCURRENCE RELATED OR RELATING TO ANY OF THE FOREGOING TAKING PLACE ON OR BEFORE THE EFFECTIVE DATE RELATED OR RELATING TO THE FOREGOING INCLUDING ALL RELIEF OBTAINED BY THE DEBTORS IN THE CHAPTER 11 CASES. FOR THE AVOIDANCE OF DOUBT, THE LBM RELEASED PARTIES, TO THE EXTENT THAT LBM HAS NOT WITHDRAWN FROM THE SETTLEMENT DESCRIBED IN ARTICLE IV.I OF THIS PLAN, SHALL CONSTITUTE RELEASED PARTIES WITH RESPECT TO THIS DEBTOR RELEASE.

NOTWITHSTANDING ANYTHING TO THE CONTRARY IN THE FOREGOING, THE RELEASES SET FORTH ABOVE DO NOT RELEASE: (1) POST-EFFECTIVE DATE OBLIGATIONS OF ANY PARTY OR ENTITY UNDER THE PLAN, THE CONFIRMATION ORDER, ANY WIND DOWN TRANSACTION, OR ANY OTHER DOCUMENT, INSTRUMENT, OR AGREEMENT (INCLUDING THOSE SET FORTH IN THE PLAN SUPPLEMENT) EXECUTED TO IMPLEMENT THE PLAN, INCLUDING THE VIDA EXIT FINANCING FACILITY DOCUMENTS, OR ANY CLAIM OR OBLIGATION ARISING UNDER THE PLAN; (2) THE RIGHTS OF ANY HOLDER OF ALLOWED CLAIMS TO RECEIVE DISTRIBUTIONS UNDER THE PLAN; (3) THE RETAINED CAUSES OF ACTION; (4) ANY CLAIMS RELATED TO ANY ACT OR OMISSION THAT IS DETERMINED IN A FINAL ORDER TO HAVE CONSTITUTED ACTUAL FRAUD, WILLFUL MISCONDUCT, INTENTIONAL BREACH OF FIDUCIARY DUTY, OR GROSS NEGLIGENCE; (5) THE DEBTORS' PREPETITION LEGAL COUNSEL SOLELY WITH RESPECT TO CLAIMS OR CAUSES OF ACTION ARISING FROM SUCH COUNSEL'S PREPETITION ADVICE TO THE DEBTORS AND/OR ANY FORMER DIRECTORS OR OFFICERS OF THE DEBTORS OTHER THAN ADVICE DIRECTLY RELATING TO THE PREPARATION AND FILING OF THE CHAPTER 11 CASES (IT BEING UNDERSTOOD ANY PREPETITION ADVICE TO THE DEBTORS RELATING TO PREPETITION TRANSACTIONS BETWEEN THE DEBTORS AND BENEFICIENT SHALL NOT CONSTITUTE ADVICE DIRECTLY RELATING TO THE PREPARATION AND FILING OF THE CHAPTER 11 CASES); OR (6) ANY NON-RELEASED PARTY.

ENTRY OF THE CONFIRMATION ORDER SHALL CONSTITUTE THE BANKRUPTCY COURT'S APPROVAL, PURSUANT TO BANKRUPTCY RULE 9019, OF THE FOREGOING DEBTOR RELEASE, WHICH INCLUDES BY REFERENCE EACH OF THE RELATED PROVISIONS AND DEFINITIONS CONTAINED IN THE PLAN, AND FURTHER, SHALL CONSTITUTE THE BANKRUPTCY COURT'S FINDING THAT THE DEBTOR RELEASE IS: (A) IN EXCHANGE FOR THE GOOD AND VALUABLE CONSIDERATION PROVIDED BY THE RELEASED PARTIES, INCLUDING, WITHOUT LIMITATION, THE RELEASED PARTIES' CONTRIBUTIONS TO FACILITATING THE WIND DOWN TRANSACTIONS AND IMPLEMENTING THE PLAN; (B) A GOOD FAITH SETTLEMENT AND COMPROMISE OF THE CLAIMS RELEASED BY THE DEBTOR RELEASE; (C) IN THE BEST INTERESTS OF THE DEBTORS AND ALL HOLDERS OF CLAIMS AND INTERESTS; (D) FAIR, EQUITABLE, AND REASONABLE; (E) GIVEN AND MADE

AFTER DUE NOTICE AND OPPORTUNITY FOR HEARING; AND (F) A BAR TO ANY OF THE DEBTORS, THE WIND DOWN DEBTORS, OR THE DEBTORS' ESTATES ASSERTING ANY CLAIM OR CAUSE OF ACTION RELEASED PURSUANT TO THE DEBTOR RELEASE.

“RELEASED PARTY” MEANS, COLLECTIVELY, AND IN EACH CASE IN THEIR RESPECTIVE CAPACITIES AS SUCH AND SUBJECT TO THE LIMITATIONS SET FORTH IN ARTICLE VIII.C HEREOF: (A) (I) THE DEBTORS AND THE WIND DOWN DEBTORS, (II) VIDA, (III) THE BONDHOLDER COMMITTEE AND EACH OF ITS MEMBERS, (IV) ANTHONY R. HORTON, IN HIS CAPACITIES AS AN INDEPENDENT DIRECTOR AND DIRECTOR OF THE DEBTORS, (V) JEFFREY S. STEIN, IN HIS CAPACITIES AS AN OFFICER, AN INDEPENDENT DIRECTOR, AND A DIRECTOR OF THE DEBTORS, (VI) MICHAEL A. TUCKER, IN HIS CAPACITY AS AN OFFICER OF THE DEBTORS, (VII) THE DLP INDEPENDENT DIRECTORS, (VIII) FTI CONSULTING, INC., (IX) PJT PARTNERS LP, AND (X) ANY OTHER PROFESSIONAL RETAINED BY THE DEBTORS, THE INDEPENDENT DIRECTORS, THE DLP INDEPENDENT DIRECTORS, OR THE BONDHOLDER COMMITTEE BY ORDER OF THE BANKRUPTCY COURT IN THE CHAPTER 11 CASES OR ANY PROFESSIONAL RETAINED BY ANY OF THE MEMBERS OF THE BONDHOLDER COMMITTEE, EACH IN SUCH CAPACITY; AND (B) SOLELY TO THE EXTENT AND ON THE TERMS AND CONDITIONS SET FORTH IN THIS PLAN, THE LBM RELEASED PARTIES.

“NON-RELEASED PARTIES” SHALL MEAN ANY ENTITIES THAT ARE NOT RELEASED PARTIES, WHICH ENTITIES SHALL INCLUDE, WITHOUT LIMITATION, BENEFICIENT, ITS CURRENT AND FORMER DIRECTORS AND OFFICERS (INCLUDING, WITHOUT LIMITATION, BRADLEY K. HEPPNER, THOMAS O. HICKS, BRUCE W. SCHNITZER, DENNIS P. LOCKHART, AND PETER T. CANGANY), HCLP NOMINEES, L.L.C., THE DEBTORS' FORMER DIRECTORS AND OFFICERS (INCLUDING, WITHOUT LIMITATION, MURRAY HOLLAND AND TIMOTHY EVANS) IN THEIR CAPACITY OR CAPACITIES AS SUCH, AND ANY ENTITIES AFFILIATED WITH OR OTHERWISE RELATED TO THE FOREGOING.

Article VIII.E of the Plan provides for an exculpation of certain parties (the “**Exculpation**”):

EXCEPT AS OTHERWISE EXPRESSLY STATED IN THIS PLAN OR THE CONFIRMATION ORDER, AS OF THE EFFECTIVE DATE, EACH EXCULPATED PARTY SHALL BE DEEMED TO BE RELEASED AND EXCULPATED FROM ANY CLAIM, OBLIGATION, CAUSE OF ACTION, OR LIABILITY FOR ANY EXCULPATED CLAIM, EXCEPT FOR CLAIMS RELATED TO ANY ACT OR OMISSION THAT IS DETERMINED IN A FINAL ORDER TO HAVE CONSTITUTED INTENTIONAL BREACH OF FIDUCIARY DUTY, ACTUAL FRAUD, WILLFUL MISCONDUCT, OR GROSS NEGLIGENCE, BUT IN ALL RESPECTS EACH DEBTOR AND EACH EXCULPATED PARTY SHALL BE ENTITLED TO REASONABLY RELY UPON THE ADVICE OF COUNSEL WITH RESPECT TO THEIR DUTIES AND RESPONSIBILITIES PURSUANT TO THE PLAN. THE EXCULPATED PARTIES HAVE, AND UPON THE CONSUMMATION OF THE PLAN, SHALL BE DEEMED TO

HAVE, PARTICIPATED IN GOOD FAITH AND IN COMPLIANCE WITH APPLICABLE LAW WITH REGARD TO THE RESTRUCTURING OF CLAIMS AND INTERESTS IN THE CHAPTER 11 CASES AND IN CONNECTION WITH THE WIND DOWN TRANSACTIONS, THE NEGOTIATION, FORMULATION, OR PREPARATION OF THE WIND DOWN DOCUMENTS OR RELATED AGREEMENTS, INSTRUMENTS, OR OTHER DOCUMENTS (INCLUDING, FOR THE AVOIDANCE OF DOUBT, PROVIDING ANY LEGAL OPINION REQUESTED BY ANY ENTITY REGARDING ANY TRANSACTION, CONTRACT, INSTRUMENT, DOCUMENT, OR OTHER AGREEMENT CONTEMPLATED BY THE PLAN OR THE RELIANCE BY ANY RELEASED PARTY ON THE PLAN OR THE CONFIRMATION ORDER IN LIEU OF SUCH LEGAL OPINION) IN CONNECTION WITH THE PLAN, AND THE SOLICITATION OF THE PLAN AND DISTRIBUTIONS PURSUANT TO THE PLAN AND, THEREFORE, ARE NOT, AND ON ACCOUNT OF SUCH DISTRIBUTIONS SHALL NOT BE, LIABLE AT ANY TIME FOR THE VIOLATION OF ANY APPLICABLE LAW, RULE, OR REGULATION GOVERNING THE SOLICITATION OF ACCEPTANCES OR REJECTIONS OF THE PLAN OR SUCH DISTRIBUTIONS MADE PURSUANT TO THE PLAN, EXCEPT FOR CLAIMS RELATED TO ANY ACT OR OMISSION THAT IS DETERMINED IN A FINAL ORDER TO HAVE CONSTITUTED INTENTIONAL BREACH OF FIDUCIARY DUTY, ACTUAL FRAUD, WILLFUL MISCONDUCT, OR GROSS NEGLIGENCE. THE DEBTORS AND THE CREDITOR PROPONENTS AGREE THAT (1) NEITHER THE ACT ITSELF OF FILING OR PROSECUTING A MOTION TO APPROVE A SETTLEMENT OF ANY ESTATE CAUSES OF ACTION WITH BENEFICIENT, ANY OF ITS AFFILIATES OR RELATED PARTIES, AND/OR ANY OTHER NON-RELEASED PARTY NOR THE ACT ITSELF OF FILING OR PROSECUTING ANY OBJECTION TO ANY SUCH SETTLEMENT IN AND OF ITSELF CONSTITUTES AN INTENTIONAL BREACH OF FIDUCIARY DUTY, AND (2) ANY CLAIMS THAT THE DEBTORS OR THE CREDITOR PROPONENTS MAY SEEK TO BRING AGAINST ANY EXCULPATED PARTY SHALL BE LIMITED TO ANY ACTIONS OF SUCH EXCULPATED PARTY SOLELY AFTER THE DATE OF EXECUTION OF THE MEDIATION AGREEMENT; PROVIDED THAT ANY SUCH CLAIMS MUST BE FILED EXCLUSIVELY IN THE BANKRUPTCY COURT AND IN ACCORDANCE WITH THE FEDERAL RULES OF CIVIL PROCEDURES, AND SUCH CLAIMS SHALL BE PLED WITH SPECIFICITY WITH RESPECT TO THE WHO, WHAT, WHEN, WHERE, AND HOW OF THE ALLEGED WRONGFUL CONDUCT.

“EXCULPATED PARTY” MEANS, COLLECTIVELY, AND IN EACH CASE, IN THEIR RESPECTIVE CAPACITIES AS SUCH: (A) JEFFREY S. STEIN, IN HIS CAPACITIES AS AN OFFICER, AN INDEPENDENT DIRECTOR, AND A DIRECTOR OF THE DEBTORS; (B) ANTHONY R. HORTON, IN HIS CAPACITIES AS AN INDEPENDENT DIRECTOR AND DIRECTOR OF THE DEBTORS; (C) MICHAEL A. TUCKER, IN HIS CAPACITY AS AN OFFICER OF THE DEBTORS; (D) THE NON-MANAGEMENT DIRECTORS, IN THEIR CAPACITY AS SUCH; (E) THE DLP INDEPENDENT DIRECTORS, IN THEIR CAPACITY AS SUCH; (F) THE MEMBERS OF THE BONDHOLDER COMMITTEE, IN THEIR CAPACITY AS SUCH; (G) ANY PROFESSIONAL RETAINED BY THE DEBTORS, THE INDEPENDENT DIRECTORS, THE DLP INDEPENDENT DIRECTORS, THE BONDHOLDER COMMITTEE, IN

SUCH PROFESSIONALS' CAPACITY AS SUCH; AND (H) ANY PROFESSIONAL RETAINED BY ANY OF THE MEMBERS OF THE BONDHOLDER COMMITTEE, EACH IN SUCH PROFESSIONALS' CAPACITY AS SUCH.

“EXCULPATED CLAIM” MEANS ANY CLAIM RELATED TO ANY ACT OR OMISSION FROM THE PETITION DATE TO THE EFFECTIVE DATE IN CONNECTION WITH, RELATING TO, OR ARISING OUT OF: (A) THE CHAPTER 11 CASES; (B) THE FORMULATION, PREPARATION, DISSEMINATION, OR NEGOTIATION OF ANY DOCUMENT IN CONNECTION WITH THE CHAPTER 11 CASES; (C) ANY CONTRACT, INSTRUMENT, RELEASE, AND/OR OTHER AGREEMENT OR DOCUMENT CREATED OR ENTERED INTO IN CONNECTION WITH THE CHAPTER 11 CASES; (D) THE PURSUIT OF CONSUMMATION; AND/OR (E) THE FILING, ADMINISTRATION, AND/OR IMPLEMENTATION OF THE CHAPTER 11 CASES, OR THE DISTRIBUTION OF PROPERTY IN CONNECTION THEREWITH OR THEREUNDER; PROVIDED, THAT, FOR THE AVOIDANCE OF DOUBT, ANY PREPETITION ADVICE PROVIDED BY ANY LEGAL PROFESSIONALS IN CONNECTION WITH PREPETITION TRANSACTIONS BETWEEN THE DEBTORS AND BENEFICIENT SHALL NOT CONSTITUTE ANY ACT OR OMISSION THAT IS COVERED BY THIS DEFINITION OF EXCULPATED CLAIM; PROVIDED, FURTHER, THAT, NOTWITHSTANDING THE FOREGOING, EXCULPATED CLAIMS SHALL NOT INCLUDE ANYTHING RELATED TO ANY ACT OR OMISSION THAT IS DETERMINED IN A FINAL ORDER TO HAVE CONSTITUTED ACTUAL FRAUD, WILLFUL MISCONDUCT, INTENTIONAL BREACH OF FIDUCIARY DUTY, OR GROSS NEGLIGENCE.

Article VIII.G of the Plan establishes an injunction (the “Injunction”):

EXCEPT AS OTHERWISE EXPRESSLY PROVIDED IN THE PLAN OR THE CONFIRMATION ORDER OR FOR OBLIGATIONS OR DISTRIBUTIONS REQUIRED TO BE PAID PURSUANT TO THE PLAN OR THE CONFIRMATION ORDER, ALL ENTITIES WHO HAVE HELD, HOLD, OR MAY HOLD CLAIMS THAT HAVE BEEN RELEASED PURSUANT TO ARTICLE VIII HEREOF ARE PERMANENTLY ENJOINED, FROM AND AFTER THE EFFECTIVE DATE, FROM TAKING ANY OF THE FOLLOWING ACTIONS AGAINST, AS APPLICABLE, THE DEBTORS, THE RELEASED PARTIES, OR THE EXCULPATED PARTIES: (1) COMMENCING OR CONTINUING IN ANY MANNER ANY ACTION OR OTHER PROCEEDING OF ANY KIND ON ACCOUNT OF OR IN CONNECTION WITH OR WITH RESPECT TO ANY OF THE CLAIMS OR INTERESTS RELEASED HEREUNDER; (2) ENFORCING, ATTACHING, COLLECTING, OR RECOVERING BY ANY MANNER OR MEANS ANY JUDGMENT, AWARD, DECREE, OR ORDER AGAINST SUCH ENTITIES ON ACCOUNT OR IN CONNECTION WITH OR WITH RESPECT TO ANY CLAIMS OR INTERESTS RELEASED HEREUNDER; (3) CREATING, PERFECTING, OR ENFORCING ANY LIEN OR ENCUMBRANCE OF ANY KIND AGAINST SUCH ENTITIES OR THE PROPERTY OF SUCH ENTITIES ON ACCOUNT OR IN CONNECTION WITH OR WITH RESPECT TO ANY CLAIMS OR INTERESTS RELEASED HEREUNDER; (4) ASSERTING ANY RIGHT OF SETOFF, SUBROGATION, OR RECOUPMENT OF ANY KIND AGAINST ANY OBLIGATION

DUE FROM SUCH ENTITIES OR AGAINST THE PROPERTY OR THE ESTATES OF SUCH ENTITIES ON ACCOUNT OR IN CONNECTION WITH OR WITH RESPECT TO ANY CLAIMS OR INTERESTS RELEASED HEREUNDER, UNLESS SUCH HOLDER HAS FILED A MOTION REQUESTING THE RIGHT TO PERFORM SUCH SETOFF ON OR BEFORE THE EFFECTIVE DATE, AND NOTWITHSTANDING AN INDICATION OF A CLAIM OR INTEREST OR OTHERWISE THAT SUCH HOLDER ASSERTS, HAS, OR INTENDS TO PRESERVE ANY RIGHT OF SETOFF PURSUANT TO APPLICABLE LAW OR OTHERWISE; AND (5) COMMENCING OR CONTINUING IN ANY MANNER ANY ACTION OR OTHER PROCEEDING OF ANY KIND ON ACCOUNT OF OR IN CONNECTION WITH OR WITH RESPECT TO ANY CLAIMS OR INTERESTS RELEASED OR SETTLED PURSUANT TO THIS PLAN.

UPON ENTRY OF THE CONFIRMATION ORDER, ALL HOLDERS OF CLAIMS AND INTERESTS AND THEIR RESPECTIVE CURRENT AND FORMER EMPLOYEES, AGENTS, OFFICERS, DIRECTORS, PRINCIPALS, AND DIRECT AND INDIRECT AFFILIATES SHALL BE ENJOINED FROM TAKING ANY ACTIONS TO INTERFERE WITH THE IMPLEMENTATION OR CONSUMMATION OF THIS PLAN. EXCEPT AS OTHERWISE SET FORTH IN THE CONFIRMATION ORDER, EACH HOLDER OF AN ALLOWED CLAIM OR ALLOWED INTEREST, AS APPLICABLE, BY ACCEPTING, OR BEING ELIGIBLE TO ACCEPT, DISTRIBUTIONS UNDER THIS PLAN SHALL BE DEEMED TO HAVE CONSENTED TO THE INJUNCTION PROVISIONS SET FORTH HEREIN.

Item 4. Certifications.

By signing this Ballot, the undersigned certifies to the Court and the Debtors that:

- (a) as of the Voting Record Date, either: (i) the Entity is the direct Holder of the Bond Claims being voted; or (ii) the Entity is an authorized signatory, with full power and authority to vote to accept or reject the Plan with respect to the Claims identified in Item 1 above, for an Entity that is a direct Holder of the Bond Claims being voted;
- (b) the Entity (or in the case of an authorized signatory, the Holder) has received the Solicitation Package and acknowledges that the solicitation is being made pursuant to the terms and conditions set forth therein;
- (c) the Entity has cast the same vote with respect to all of its direct-held Bond Claims; and
- (d) no other Ballots with respect to the amount of the Bond Claims in Item 1 have been cast or, if any other Ballots have been cast with respect to such Bond Claims, then any such earlier Ballots are hereby revoked.

Name of Holder: _____

(Print or Type)

Signature: _____

Name of Signatory: _____
(If other than Holder)

Title (and capacity, if other than Holder): _____

Address: _____

Telephone Number: _____

Email: _____

Date Completed: _____

IF THE SOLICITATION AGENT DOES NOT ACTUALLY RECEIVE THIS BALLOT ON OR BEFORE MAY 31, 2023 AT 4:00 P.M. PREVAILING CENTRAL TIME, AND IF THE VOTING DEADLINE IS NOT EXTENDED, YOUR VOTE TRANSMITTED BY THIS BALLOT MAY BE COUNTED TOWARD CONFIRMATION OF THE PLAN ONLY IN THE DISCRETION OF THE DEBTORS.

INSTRUCTIONS FOR COMPLETING THIS BALLOT

1. The Debtors are soliciting the votes of Holders of Claims with respect to the Plan. **PLEASE READ THE PLAN AND THE DISCLOSURE STATEMENT CAREFULLY BEFORE COMPLETING THIS BALLOT.**
2. The Plan can be confirmed by the Court and thereby made binding upon you if it is accepted by the Holders of at least two-thirds in total dollar amount and more than one-half in number of Claims that actually vote on the Plan and if the Plan otherwise satisfies the requirements for confirmation provided by section 1129(a) of the Bankruptcy Code. Please review the Disclosure Statement for more information.
3. To ensure that your Ballot is counted, you *must* complete and submit this Ballot as instructed herein. **Ballots will not be accepted by facsimile.**
4. **Use of Ballot.** To ensure that your Ballot is counted, you must: (a) complete your Ballot in accordance with these instructions; (b) clearly indicate your decision either to accept or reject the Plan in the box provided in Item 2 of the Ballot; and (c) clearly sign and submit your Ballot as instructed herein.
5. Your completed Ballot *must* be returned to the *Solicitation Agent* so as to be *actually received* by the Solicitation Agent on or before the Voting Deadline. **Do not** send Ballots to the Debtors, Indenture Trustee, Bondholder Committee, any advisors to the foregoing, the Court. **The Voting Deadline is May 31, 2023 at 4:00 p.m. (prevailing Central Time).**
6. If a Ballot is received by the Solicitation Agent after the Voting Deadline and if the Voting Deadline is not extended, it may not be counted. Additionally, the following Ballots will not be counted:
 - (a) any Ballot that partially rejects and partially accepts the Plan;
 - (b) Ballots delivered to any party other than the Solicitation Agent;
 - (c) Ballots sent by facsimile or other unapproved means;
 - (d) any Ballot that is illegible or contains insufficient information to permit the identification of the Holder of the Claim;
 - (e) any Ballot cast by an Entity that does not hold a Claim or Interest entitled to vote pursuant to the Plan or Solicitation Procedures;
 - (f) any Ballot submitted by a Holder not entitled to vote pursuant to the Plan or Solicitation Procedures;
 - (g) any unsigned Ballot (for the avoidance of doubt, Ballots validly submitted through the E-Ballot Portal or via email will be deemed signed); and/or

- (h) any Ballot not marked to accept or reject the Plan or any Ballot marked both to accept and reject the Plan.
- 7. The method of delivery of Ballots to the Solicitation Agent is at the election and risk of each direct Holder of a Class 3 Bond Claim. Except as otherwise provided herein, such delivery will be deemed made only when the Solicitation Agent *actually receives* the originally executed Ballot. In all cases, Holders should allow sufficient time to assure timely delivery.
- 8. If multiple Ballots are received from the same Holder of a Class 3 Bond Claim with respect to the same Class 3 Bond Claim prior to the Voting Deadline, the latest, timely received, and properly completed Ballot will supersede and revoke any earlier received Ballots.
- 9. You must vote all of your Class 3 Bond Claims, regardless if such Claims are asserted against one or multiple Debtors, either to accept or reject the Plan and may *not* split your vote.
- 10. This Ballot does *not* constitute, and shall not be deemed to be, (a) a Proof of Claim or (b) an assertion or admission of a Claim.
- 11. **Please be sure to sign and date your Ballot.** If you are signing a Ballot in your capacity as a trustee, executor, administrator, guardian, attorney in fact, officer of a corporation, or otherwise acting in a fiduciary or representative capacity, you must indicate such capacity when signing and, if required or requested by the Solicitation Agent, the Debtors, or the Court, you must submit proper evidence to the requesting party to so act on behalf of such Holder. In addition, please provide your name and mailing address if it is different from that set forth on the attached mailing label or if no such mailing label is attached to the ballot. You may not mark a vote to accept or reject the Plan or complete Item 2 of the Ballot unless expressly authorized in writing by the Holder to vote on a chapter 11 plan on such Holder's behalf.

PLEASE SUBMIT YOUR BALLOT PROMPTLY

IF YOU HAVE ANY QUESTIONS REGARDING THIS BALLOT, THESE VOTING INSTRUCTIONS, OR THE PROCEDURES FOR VOTING, PLEASE CALL THE SOLICITATION AGENT AT:

U.S. TOLL FREE: (888) 508-2507

OR EMAIL GWGINFO@DONLINRECANO.COM

OR CONTACT THE OFFICIAL COMMITTEE OF BONDHOLDERS:

BY EMAIL: GWGBondholders@akingump.com

WEBSITE: <https://www.donlinrecano.com/gwgbondholders>

IF THE SOLICITATION AGENT DOES NOT ACTUALLY RECEIVE THIS BALLOT ON OR BEFORE THE VOTING DEADLINE, WHICH IS ON MAY 31, 2023 AT 4:00 P.M., PREVAILING CENTRAL TIME, AND IF THE VOTING DEADLINE IS NOT EXTENDED, YOUR VOTE TRANSMITTED HEREBY MAY BE COUNTED ONLY IN THE DISCRETION OF THE DEBTORS.

Exhibit 3B

Class 3 Bond Claims (Indirect-Held) Master Ballot

IN THE UNITED STATES BANKRUPTCY COURT
FOR THE SOUTHERN DISTRICT OF TEXAS
HOUSTON DIVISION

In re:)	Chapter 11
GWG Holdings, Inc., <i>et al.</i> , ¹)	Case No. 22-90032 (MI)
Debtors.)	(Jointly Administered)

**MASTER BALLOT FOR ACCEPTING OR REJECTING
THE DEBTORS' SECOND AMENDED JOINT CHAPTER 11 PLAN**

Class 3: Bond Claims (Indirect-Held)

PLEASE READ AND FOLLOW THE ENCLOSED INSTRUCTIONS FOR COMPLETING BALLOTS CAREFULLY BEFORE COMPLETING THIS BALLOT.

FOR YOUR VOTE TO BE COUNTED, THIS BALLOT MUST BE COMPLETED, EXECUTED, AND RETURNED SO AS TO BE ACTUALLY RECEIVED BY THE SOLICITATION AGENT BY MAY 31, 2023 AT 4:00 P.M. (PREVAILING CENTRAL TIME) THE (“VOTING DEADLINE”). IF THIS BALLOT IS NOT PROPERLY COMPLETED, EXECUTED, AND RECEIVED BY THE SOLICITATION AGENT ON OR BEFORE THE VOTING DEADLINE, THEN THE VOTES TRANSMITTED BY THIS BALLOT WILL NOT BE COUNTED.

ACCESS TO SOLICITATION MATERIALS:

THE PLAN, DISCLOSURE STATEMENT AND DISCLOSURE STATEMENT ORDER, INCLUDING THE SOLICITATION PROCEDURES AND THE BONDHOLDER COMMITTEE LETTER MAY BE ACCESSED FREE OF CHARGE AT [HTTPS://WWW.DONLINRECANO.COM/CLIENTS/GWG/INDEX](https://www.donlinrecano.com/clients/gwg/index) BY CLICKING ON THE “SOLICITATION MATERIALS” LINK ON THE WEBSITE’S LEFT HAND NAVIGATION PANEL.

YOU CAN ALSO OBTAIN COPIES IN PAPER FORMAT OF ANY SOLICITATION MATERIALS (A) FREE OF CHARGE BY (I) ACCESSING THE DEBTORS’ RESTRUCTURING WEBSITE AT

¹ The Debtors in these chapter 11 cases, along with the last four digits of each Debtor’s federal tax identification number, are: GWG Holdings, Inc. (2607); GWG Life, LLC (6955); GWG Life USA, LLC (5538) GWG DLP Funding IV, LLC (2598); GWG DLP Funding VI, LLC (6955) and GWG DLP Funding Holdings VI, LLC (6955). The location of Debtor GWG Holdings, Inc.’s principal place of business and the Debtors’ service address is 325 N. St. Paul Street, Suite 2650, Dallas, TX 75201. Further information regarding the Debtors and these chapter 11 cases is available at the website of the Debtors’ claims and noticing agent: <https://donlinrecano.com/gwg>.

[HTTPS://WWW.DONLINRECANO.COM/CLIENTS/GWG/INDEX](https://www.donlinrecano.com/clients/gwg/index); (II) WRITING TO DONLIN, RECANO & COMPANY, INC., RE: GWG HOLDINGS, INC., ET AL., P.O. BOX 199043, BLYTHEBOURNE STATION, BROOKLYN, NY 11219; (III) CALLING 1 (888) 508-2507 (U.S. TOLL FREE); OR (IV) EMAILING GWGINFO@DONLINRECANO.COM; OR (B) FOR A FEE VIA PACER AT [HTTPS://ECF.TXSB.USCOURTS.GOV/](https://ecf.txsb.uscourts.gov/).

Solicitation Overview

The above-captioned debtors and debtors in possession (collectively, the “Debtors”), are soliciting votes with respect to the Plan as set forth in the *Disclosure Statement for the Debtors’ Second Amended Joint Chapter 11 Plan* [Docket No. 1682] (as may be amended, supplemented, or modified, the “Disclosure Statement”) and the *Debtors’ Second Amended Joint Chapter 11 Plan* [Docket No. 1678] (as may be amended, supplemented, or modified, the “Plan”).² The Bankruptcy Court for the Southern District of Texas (the “Court”) has approved the Disclosure Statement as containing adequate information pursuant to section 1125 of the Bankruptcy Code, by entry of an order on April 21, 2023 [Docket No. 1681³] (the “Disclosure Statement Order”). Court approval of the Disclosure Statement does not indicate approval of the Plan by the Court.

You are receiving this master ballot (this “Master Ballot”) because you are the Nominee (as defined below) of a Beneficial Holder⁴ of a Claim in Class 3 (the “Voting Class”) as of February 24, 2023 (the “Voting Record Date”).

This Master Ballot is to be used by you as a bank, broker, securities intermediary, registered investment advisor, or other nominee, or an agent of any of the foregoing (each of the foregoing, a “Nominee”); or as the proxy holder of a Nominee for certain Beneficial Holders’ Class 3 Bond Claims to transmit to the Solicitation Agent the votes of such Beneficial Holders in respect of their Class 3 Bond Claims to accept or reject the Plan. To use this Master Ballot, you must meet all applicable standards to receive informed consent from the Beneficial Holders for whom you are Nominee. The CUSIP numbers (the “CUSIP”) for Class 3 Bond Claims entitled to vote and of which you are the Nominee are set forth herein.

The Disclosure Statement describes the rights and treatment for each Class. The Disclosure Statement, the Plan, the Bondholder Summary and certain other materials (the “Solicitation Package”) have been distributed under separate cover from this Master Ballot. This Master Ballot may not be used for any purpose other than for casting votes to accept or reject the Plan and making certain certifications with respect thereto. Once completed and returned in accordance with the attached instructions, the votes on the Plan will be counted as set forth herein.

² Capitalized terms used but not otherwise defined herein shall have the meanings ascribed to such terms in the Plan, the Disclosure Statement, or the Disclosure Statement Order, as applicable.

³ As modified pursuant to the order entered at docket 1692.

⁴ “Beneficial Holder” is a beneficial owner of Class 3 Claims whose Claims have not been satisfied prior to the Voting Record Date pursuant to court order or otherwise, as reflected in the records maintained by the Nominees (as defined herein) holding through the Depository Trust Company or other relevant security depository, as of the Voting Record Date.

You are authorized to collect votes to accept or to reject the Plan from Beneficial Holders in accordance with your customary practices, including the use of a “voting information form” in lieu of (or in addition to) a Beneficial Holder Ballot, and collecting votes from Beneficial Holders through online voting, by phone, facsimile, or other electronic means.

The Court may confirm the Plan and thereby bind all Beneficial Holders of Claims and Interests. To have the votes of your Beneficial Holders count as either an acceptance or rejection of the Plan, you must complete and return this Master Ballot so that the Solicitation Agent **actually receives** it on or before the Voting Deadline.

**THE VOTING DEADLINE IS 4:00 P.M., PREVAILING CENTRAL TIME,
ON MAY 31, 2023.**

Item 1. Certification of Authority to Vote.

The undersigned certifies that, as of the Voting Record Date, the undersigned (please check the applicable box):

- is the record holder of the Claims listed in Item 2 below, and is a broker, bank, or other Nominee for the beneficial owners of the aggregate principal amount of such bonds; or
- is acting under a power of attorney and/or agency (a copy of which will be provided upon request) granted by a broker, bank, or other Nominee that is the registered holder of the aggregate principal amount of the Claims listed in Item 2 below; or
- has been granted a proxy (an original of which is attached hereto) from a broker, bank, or other Nominee, or a beneficial owner, that is the registered holder of the aggregate principal amount of the Claims listed in Item 2 below, and accordingly, has full power and authority to vote to accept or reject the Plan, on behalf of the beneficial owners of the Claims described in Item 2.

Item 2. Claims in the Voting Class Vote on Plan

The undersigned transmits the following votes and releases of Beneficial Holders of Claims against the Debtors in the Voting Class as set forth below and certifies that the following Beneficial Holders of the Classes of Claims, as identified by their respective customer account numbers set forth below, are Beneficial Holders of such securities as of the Voting Record Date, and have delivered to the undersigned, as Nominee, Ballots casting such votes as set forth below.

Indicate in the appropriate column below the aggregate principal amount voted for each account or attach such information to this Master Ballot in the form of the following table. Please note that each Beneficial Holder must vote all of their Claims in the Voting Class either to accept or reject the Plan and may not split such vote. Any Ballot executed by the Beneficial Holder that does not indicate an acceptance or rejection of the Plan, or that indicates both an acceptance and a rejection of the Plan in the Voting Class will not be counted. If the Beneficial Holder has checked the box on Item 2 of the Beneficial Holder Ballot pertaining to the releases by holders of Claims, as detailed in Article VIII.D of the Plan, please place an X in the Item 3 column of the table below.

Your Customer Account Number for Each Beneficial Holder Who Voted in this Plan Class	Principal Amount Held as of the Voting Record Date	Item 2 Indicate the vote cast on each Beneficial Holder Ballot by placing an "X" in the appropriate column below.	
		Accept the Plan	Reject the Plan
CUSIP No. []			
1.	\$		
2.	\$		
3.	\$		
4.	\$		
5.	\$		
6.	\$		
TOTALS	\$		

Item 3. Certification as to Transcription of Information from Item 3 of the Ballots as to Claims in Voting Classes Voted Through Other Ballots.

The undersigned certifies that the following information is a true and accurate schedule on which the undersigned has transcribed the information, if any, provided in Item 3 of each Ballot received from a Beneficial Holder. Please use additional sheets of paper if necessary.

Your Customer Account Number for Each Beneficial Holder Who Completed Item 3 of the Ballots	TRANSCRIBE FROM ITEM 3 OF THE BENEFICIAL HOLDER BALLOTS:				Indicate whether Beneficial Holder in each row voted to <u>Accept</u> or <u>Reject</u> the Plan
	Account Number of Other Claims Voted	DTC Participant Name and Number	Principal Amount of Other Claims Voted	CUSIP(s) of Other Claims Voted	
Class 3 – Bond Claims					
1.			\$		
2.			\$		
3.			\$		
4.			\$		
5.			\$		

6.			\$		
7.			\$		
7.			\$		
9.			\$		
10.			\$		

Item 4. Certifications.

Upon execution of this Master Ballot, the undersigned certifies that:

1. it has received a copy of the Disclosure Statement, the Plan, the Ballots, the Bondholder Summary, and the remainder of the Solicitation Package and has delivered the same to the Beneficial Holders of the Claims in the Voting Class listed in Item 2 above or delivered such materials via other customary communications used to solicit or collect votes; and
2. either (a) it has received appropriate, completed voting instructions from each Beneficial Holder listed in Item 2 of this Master Ballot; (b) it is the registered Beneficial Holder of the securities being voted, or (c) it has been expressly authorized in writing by each such Beneficial Holder to vote on the Plan; and
3. it has properly disclosed: (a) the number of unique Beneficial Holders who completed Ballots; (b) the respective amounts of the Claims in the Voting Class as set forth in Item 2, as the case may be, by each Beneficial Holder who completed a Ballot; (c) each such Beneficial Holder’s respective vote concerning the Plan as cast by such Beneficial Holder; (d) each such Beneficial Holder’s certification as to other Claims voted; and (e) the customer account or other identification number for each such Beneficial Holder; and
4. it will maintain Ballots and evidence of separate transactions returned by Beneficial Holders (whether properly completed or defective) for at least one year after the Effective Date and disclose all such information to the Bankruptcy Court or the Debtors, as the case may be, if requested.

Name of Nominee: _____
 (Print or type)

DTC Participant Number: _____

Name of Proxy Holder or Agent
 for Nominee (if applicable): _____
 (Print or type)

Signature: _____

Name of Signatory: _____

Title: _____

Address: _____

Date Completed: _____

Email Address: _____

THIS MASTER BALLOT MUST BE ACTUALLY RECEIVED BY THE VOTING DEADLINE, WHICH IS 4:00 P.M., PREVAILING CENTRAL TIME, ON MAY 31, 2023.

PLEASE COMPLETE AND DATE THE MASTER BALLOT AND RETURN IT PROMPTLY WITH AN ORIGINAL SIGNED COPY IN THE ENVELOPE PROVIDED, OR BY REGULAR MAIL, OVERNIGHT COURIER, OR HAND DELIVERY TO THE ADDRESS BELOW, OR BY EMAIL (INSTRUCTIONS BELOW) SO THAT IT IS ACTUALLY RECEIVED BY THE SOLICITATION AGENT BY THE VOTING DEADLINE.

Via Paper Ballot. Complete, sign, and date this Ballot and return it (with an original signature) promptly in the envelope provided or:

By First Class Mail to:

GWG HOLDINGS, INC., ET AL. Balloting Center
c/o Donlin Recano Company
Attn: Voting Department
P.O. Box 199043 Blythebourne Station
Brooklyn, NY 11219

By Hand Delivery or Overnight Mail to:

GWG HOLDINGS, INC., ET AL. Balloting Center
c/o Donlin Recano Company
Attn: Voting Department
6201 15th Ave
Brooklyn, NY 11219

OR

By electronic mail:

Submit your Master Ballot via electronic mail to GWGVote@donlinrecano.com with “GWG Holdings, Inc. Class 3 Master Ballot” in the subject line.

IMPORTANT NOTE: For any ballot cast via electronic mail, a format of the attachment must be found in the common workplace and industry standard format (i.e., industry-standard pdf file) and the received date and time in the solicitation agent’s inbox will be used as a timestamp for receipt.

Nominees that cast a Master Ballot via electronic mail should NOT also submit a paper Master Ballot.

IF YOU HAVE ANY QUESTIONS ABOUT THE SOLICITATION OR VOTING PROCESS, PLEASE CONTACT THE SOLICITATION AGENT TOLL FREE AT (888)

508-2507; OR EMAILING GWGINFO@DONLINRECANO.COM. ANY BALLOT RECEIVED AFTER THE VOTING DEADLINE OR OTHERWISE NOT IN COMPLIANCE WITH THE DISCLOSURE STATEMENT ORDER WILL NOT BE COUNTED.

MASTER BALLOTS WILL NOT BE ACCEPTED BY TELECOPY, FACSIMILE, OR OTHER ELECTRONIC MEANS OF TRANSMISSION (OTHER THAN BY E-MAIL TO GWGVOTE@DONLINRECANO.COM WITH A REFERENCE TO “GWG HOLDINGS, INC. CLASS 3 MASTER BALLOT” IN THE SUBJECT LINE).

THE MASTER BALLOT SHOULD NOT BE SENT TO THE DEBTORS, THE BANKRUPTCY COURT, OR THE DEBTORS’ FINANCIAL OR LEGAL ADVISORS.

VOTING INSTRUCTIONS

1. As described in the Disclosure Statement, the Debtors are soliciting the votes of Beneficial Holders of Class 3 Bond Claims with respect to the Plan referred to in the Disclosure Statement. Links to the Plan and the Disclosure Statement are included in the Solicitation Packages. Capitalized terms used but not defined herein shall have the meanings assigned to them in the Plan.
2. The Plan can be confirmed by the Bankruptcy Court and thereby made binding upon holders of Claims and Interests if it is accepted by the holders of at least two-thirds in amount and more than one-half in number of Claims or at least two thirds in amount of Interests in at least one Class that votes on the Plan and if the Plan otherwise satisfies the requirements for confirmation set forth in section 1129(a) of the Bankruptcy Code.
3. You should *immediately* distribute the Ballots (or other customary material used to collect votes in lieu of the Ballots) and Solicitation Package to all Beneficial Holders of Class 3 Bond Claims and take any action required to enable each such Beneficial Holder to timely vote the Claims that it holds. You may distribute the Solicitation Packages to Beneficial Holders, as appropriate, in accordance with your customary practices. You are authorized to collect votes to accept or to reject the Plan from Beneficial Holders in accordance with your customary practices, including the use of a “voting information form” in lieu of (or in addition to) a Ballot, and collecting votes from Beneficial Holders through online voting, by phone, facsimile, or other electronic means. Any Nominee that elects such a procedure shall meet all applicable standards to receive informed consent and such materials shall clearly communicate the timing requirements for Beneficial Holder Ballots to be included on the Master Ballot prior to the Voting Deadline. Any Ballot returned to you by a Beneficial Holder of a Claim shall not be counted for purposes of accepting or rejecting the Plan until you properly complete and deliver, to the Solicitation Agent, a Master Ballot that reflects the vote of such Beneficial Holders by 4:00 P.M., prevailing Central Time, on May 31, 2023, or otherwise validate the Ballot in a manner acceptable to the Solicitation Agent.

If you are transmitting the votes of any beneficial owners of Claims in Voting Classes, you may either:

- (a) “Pre-validate” the individual Beneficial Holder Ballot contained in the Solicitation Package and then forward the Solicitation Package to the Beneficial Holder of the Class 3 Claim for voting within three (3) Business Days after the receipt by such Nominee of the Solicitation Package, with the Beneficial Holder then returning the individual Beneficial Holder Ballot directly to the Solicitation Agent in the return envelope to be provided in the Solicitation Package. A Nominee “pre-validates” a Beneficial Holder Ballot by signing the Ballot and including their DTC participant name and DTC participant number; indicating the account number of the Beneficial Holder and the *principal amount* of the Class 3 Bond Claim held by the Nominee for such Beneficial Holder, applying a medallion guarantee stamp to the ballot to certify the principal amount of the Class 3 Bond Claim owned by the Beneficial Holder as of the Voting Record Date and then forwarding the Ballot together with

the Solicitation Package to the Beneficial Holder; *provided, however*, that Nominees shall not mark a vote to accept or reject the Plan or complete Item 2 of the Beneficial Holder Ballot prior to distribution of the Solicitation Packages to Beneficial Holders unless expressly authorized in writing by such Beneficial Holder to vote on a chapter 11 plan on such Beneficial Holder's behalf. The Beneficial Holder then completes the information requested on the Ballot and returns the Ballot directly to the Solicitation Agent. A list of the Beneficial Holders to whom "pre-validated" Ballots were delivered should be maintained by Nominees for inspection for at least one year from the Effective Date; OR

- (b) Within three (3) Business Days after receipt by such Nominee of the Solicitation Package, forward the Solicitation Package to the Beneficial Holder of the Class 3 Bond Claim for voting (along with a return envelope provided by and addressed to the Nominee, if applicable), with the beneficial owner then returning the individual Beneficial Holder Ballot to the Nominee; *provided, however*, that Nominees shall not mark a vote to accept or reject the Plan or complete Item 2 of the Beneficial Holder Ballot prior to distribution of the Solicitation Packages to Beneficial Holders unless such Nominee is expressly authorized in writing by the Beneficial Holder to vote on a chapter 11 plan on such Beneficial Holder's behalf. In such case, the Nominee will tabulate the votes of its respective Beneficial Holders on a Master Ballot that will be provided to the Nominee separately by the Solicitation Agent, in accordance with any instructions set forth in the instructions to the Master Ballot, and then return the Master Ballot to the Solicitation Agent. The Nominee should advise the Beneficial Holders to return their individual Beneficial Holder Ballots to the Nominee by a date calculated by the Nominee to allow it to prepare and return the Master Ballot to the Solicitation Agent so that the Master Ballot is **actually received** by the Solicitation Agent on or before the Voting Deadline.
4. With regard to any Ballots returned to you by a Beneficial Holder, you must: (a) compile and validate the votes and other relevant information of each such Beneficial Holder on the Master Ballot using the customer name or account number assigned by you to each such Beneficial Holder; (b) execute the Master Ballot; (c) transmit such Master Ballot to the Solicitation Agent by the Voting Deadline; and (d) retain such Ballots from Beneficial Holders, whether in hard copy or by electronic direction, in your files for a period of one year after the Effective Date. You may be ordered to produce the Ballots to the Debtors or the Bankruptcy Court.
5. The time by which a Ballot is **actually received** by the Solicitation Agent shall be the time used to determine whether a Ballot has been submitted by the Voting Deadline. **The Voting Deadline is May 31, 2023, at 4:00 P.M., prevailing Central Time.**
6. If a Ballot is received after the Voting Deadline, it will not be counted except as permitted by applicable law or court order. In all cases, Nominees should allow sufficient time to ensure timely delivery. No Ballot should be sent to the Debtors or the Debtors' financial or legal advisors. A Ballot will not be counted unless received by the Solicitation Agent.

7. If multiple Master Ballots are received prior to the Voting Deadline from the same Nominee with respect to the same Ballot belonging to a Beneficial Holder of a Claim, the vote on the last properly completed Master Ballot timely received will supersede and revoke the vote of such Beneficial Holder on any earlier received Master Ballot.
8. If a holder holds a Claim or Interest, as applicable, in a Voting Class against multiple Debtors, a vote on their Ballot will apply to all Debtors against whom such holder or Nominee has a Claim or Interest, as applicable, in that Voting Class.
9. If a voter simultaneously casts inconsistent duplicate Ballots, with respect to the same Claim, such Ballots shall not be counted.
10. The Ballot is not a letter of transmittal and may not be used for any purpose other than to vote to accept or reject the Plan and to make certain certifications with respect thereto. Accordingly, at this time, creditors should not surrender certificates or instruments representing or evidencing their Claims, and the Debtors will not accept delivery of any such certificates or instruments surrendered together with a Ballot.
11. The Ballot does not constitute, and shall not be deemed to be: (a) a Proof of Claim; or (b) an assertion or admission with respect to any Claim.
12. Please be sure to sign and date your Master Ballot. You should indicate that you are signing a Master Ballot in your capacity as a trustee, executor, administrator, guardian, attorney in fact, officer of a corporation, or otherwise acting in a fiduciary or representative capacity and, if required or requested by the Solicitation Agent, the Debtors, or the Court, you must submit proper evidence to the requesting party to so act on behalf of such Beneficial Holder. In addition, please provide your name and mailing address if it is different from that set forth on the attached mailing label or if no such mailing label is attached to the Master Ballot.
13. If you are both the Nominee and the Beneficial Holder of any of the Claims in the Voting Class and you wish to vote such Claims in the Voting Class, you may return a Master Ballot for such Claims in the Voting Class and you must vote your entire Claim in the Voting Class to either to accept or reject the Plan and may not split your vote. Accordingly, a Ballot, other than a Master Ballot with the votes of multiple holders, that partially rejects and partially accepts the Plan will not be counted.
14. The following Ballots and Master Ballots shall not be counted in determining the acceptance or rejection of the Plan: (a) any Ballot or Master Ballot that is illegible or contains insufficient information to permit the identification of the Beneficial Holder of the Claim; (b) any Ballot or Master Ballot cast by a Party that does not hold a Claim in a Class that is entitled to vote on the Plan; (c) any unsigned Ballot or Master Ballot; (d) any Ballot or Master Ballot not marked to accept or reject the Plan; and (e) any Ballot or Master Ballot submitted by any party not entitled to cast a vote with respect to the Plan.
15. For purposes of the numerosity requirement of section 1126(c) of the Bankruptcy Code, separate Claims held by a single Creditor in a particular Class will be aggregated and treated as if such Creditor held one Claim in such Class, and all votes related to such Claim

will be treated as a single vote to accept or reject the Plan; *provided, however*, that if separate affiliated entities hold Claims in a particular Class, these Claims will not be aggregated and will not be treated as if such Creditor held one Claim in such Class, and the vote of each affiliated entity will be counted separately as a vote to accept or reject the Plan.

The following additional rules shall apply to Master Ballots:

16. Votes cast by Beneficial Holders through a Nominee will be applied against the positions held by such entities in the Claims in the Voting Class as of the Record Date, as evidenced by the record and depository listings;
17. Votes submitted by a Nominee, whether pursuant to a Master Ballot or pre-validated Beneficial Holder Ballots, will not be counted in excess of the record amount of the Claims in the Voting Class held by such Nominee;
18. To the extent that conflicting votes or “overvotes” are submitted by a Nominee, whether pursuant to a Master Ballot or pre-validated Beneficial Holder Ballots, the Solicitation Agent will attempt to reconcile discrepancies with the Nominee;
19. To the extent that overvotes on a Master Ballot or pre-validated Beneficial Holder Ballots are not reconcilable prior to the preparation of the vote certification, the Solicitation Agent will apply the votes to accept and reject the Plan in the same proportion as the votes to accept and reject the Plan submitted on the Master Ballot or pre-validated Beneficial Holder Ballots that contained the overvote, but only to the extent of the Nominee’s position in the relevant Claims in the Voting Classes; and
20. For purposes of tabulating votes, each Beneficial Holder holding through a particular account will be deemed to have voted the principal amount relating to its holding in that particular account, although the Solicitation Agent may be asked to adjust such principal amount to reflect the Claim amount.

The Plan includes the following release, exculpation, and injunction provisions:⁴

Article VIII.C of the Plan provides for the following release:

PURSUANT TO SECTION 1123(B) OF THE BANKRUPTCY CODE, IN EXCHANGE FOR GOOD AND VALUABLE CONSIDERATION, THE ADEQUACY OF WHICH IS HEREBY CONFIRMED, ON AND AFTER THE EFFECTIVE DATE, EACH RELEASED PARTY (BUT NO NON-RELEASED PARTY) IS, AND IS DEEMED HEREBY TO BE, FULLY, CONCLUSIVELY, ABSOLUTELY, UNCONDITIONALLY, IRREVOCABLY, AND FOREVER RELEASED AND DISCHARGED BY THE DEBTORS, THE WIND DOWN DEBTORS, AND THEIR ESTATES, AND ANY PERSON SEEKING TO EXERCISE THE RIGHTS OF THE DEBTORS OR THEIR ESTATES, INCLUDING ANY

⁴ The Plan provisions referenced herein are for summary purposes only and do not include all provisions of the Plan that may affect your rights. If there is any inconsistency between the provisions set forth herein and the Plan, the Plan governs. You should read the Plan before completing this Master Ballot.

SUCCESSORS TO THE DEBTORS OR ANY ESTATES REPRESENTATIVES APPOINTED OR SELECTED PURSUANT TO SECTION 1123(B)(3) OF THE BANKRUPTCY CODE, IN EACH CASE ON BEHALF OF THEMSELVES AND THEIR RESPECTIVE SUCCESSORS, ASSIGNS, AND REPRESENTATIVES, AND ANY AND ALL OTHER ENTITIES WHO MAY PURPORT TO ASSERT ANY CAUSE OF ACTION, DIRECTLY OR DERIVATIVELY, BY, THROUGH OR FOR THE DEBTORS OR THEIR ESTATES, FROM ANY AND ALL CLAIMS AND CAUSES OF ACTION, WHETHER KNOWN OR UNKNOWN, INCLUDING ANY DERIVATIVE CLAIMS, ASSERTED OR ASSERTABLE ON BEHALF OF THE DEBTORS, WHETHER KNOWN OR UNKNOWN, FORESEEN OR UNFORESEEN, MATURED OR UNMATURED, EXISTING OR HEREAFTER ARISING, CONTINGENT OR NON-CONTINGENT, IN LAW, EQUITY, CONTRACT, TORT OR OTHERWISE, EXCEPT FOR ANY CLAIMS RELATED TO ANY ACT OR OMISSION THAT IS DETERMINED IN A FINAL ORDER TO HAVE CONSTITUTED ACTUAL FRAUD, WILLFUL MISCONDUCT, INTENTIONAL BREACH OF FIDUCIARY DUTY, OR GROSS NEGLIGENCE, THAT THE DEBTORS, THE WIND DOWN DEBTORS, OR THEIR ESTATES, INCLUDING ANY SUCCESSORS TO THE DEBTORS OR ANY ESTATES REPRESENTATIVE APPOINTED OR SELECTED PURSUANT TO SECTION 1123(B) OF THE BANKRUPTCY CODE, WOULD HAVE BEEN LEGALLY ENTITLED TO ASSERT IN THEIR OWN RIGHT (WHETHER INDIVIDUALLY OR COLLECTIVELY) OR ON BEHALF OF THE HOLDER OF ANY CLAIM OR INTEREST IN, A DEBTOR OR OTHER ENTITY, OR THAT ANY HOLDER OF ANY CLAIM AGAINST, OR INTEREST IN, A DEBTOR OR OTHER ENTITY COULD HAVE ASSERTED ON BEHALF OF THE DEBTORS, BASED ON OR RELATING TO, OR IN ANY MANNER ARISING FROM, IN WHOLE OR IN PART, THE DEBTORS (INCLUDING THE CAPITAL STRUCTURE, MANAGEMENT, OWNERSHIP OR OPERATION THEREOF), THE BUSINESS OR CONTRACTUAL ARRANGEMENT BETWEEN THE DEBTORS AND ANY RELEASED PARTY, ANY SECURITIES ISSUED BY THE DEBTORS AND THE OWNERSHIP THEREOF, THE ASSERTION OR ENFORCEMENT OF RIGHTS AND REMEDIES AGAINST THE DEBTORS, THE DEBTORS' IN- OR OUT-OF-COURT RESTRUCTURING EFFORTS, ANY AVOIDANCE ACTIONS (BUT EXCLUDING AVOIDANCE ACTIONS BROUGHT AS COUNTERCLAIMS OR DEFENSES TO CLAIMS ASSERTED AGAINST THE DEBTORS), INTERCOMPANY TRANSACTIONS BETWEEN OR AMONG A DEBTOR AND ANOTHER DEBTOR, THE FORMULATION, PREPARATION, DISSEMINATION, NEGOTIATION, OR FILING OF THE DISCLOSURE STATEMENT, THE PLAN (INCLUDING, FOR THE AVOIDANCE OF DOUBT, THE PLAN SUPPLEMENT), THE VIDA DIP FINANCING FACILITY, THE VIDA EXIT FINANCING FACILITY, OR ANY WIND DOWN TRANSACTION, CONTRACT, INSTRUMENT, RELEASE, OR OTHER AGREEMENT OR DOCUMENT (INCLUDING ANY LEGAL OPINION REQUESTED BY ANY ENTITY REGARDING ANY TRANSACTION, CONTRACT, INSTRUMENT, DOCUMENT OR OTHER AGREEMENT CONTEMPLATED BY THE PLAN OR THE RELIANCE BY ANY RELEASED PARTY ON THE PLAN OR THE CONFIRMATION ORDER IN LIEU OF SUCH LEGAL OPINION) CREATED OR ENTERED INTO IN CONNECTION WITH THE DISCLOSURE STATEMENT, THE VIDA EXIT FINANCING FACILITY DOCUMENTS, THE PLAN, OR THE PLAN SUPPLEMENT, BEFORE OR DURING THE CHAPTER 11 CASES, THE CHAPTER 11 CASES, THE

FILING OF THE CHAPTER 11 CASES, THE PURSUIT OF CONFIRMATION, THE ADMINISTRATION AND IMPLEMENTATION OF THE PLAN, INCLUDING THE ISSUANCE OR DISTRIBUTION OF SECURITIES PURSUANT TO THE PLAN, OR THE DISTRIBUTION OF PROPERTY UNDER THE PLAN, OR UPON ANY RELATED ACT OR OMISSION, TRANSACTION, AGREEMENT, EVENT, OR OTHER OCCURRENCE RELATED OR RELATING TO ANY OF THE FOREGOING TAKING PLACE ON OR BEFORE THE EFFECTIVE DATE RELATED OR RELATING TO THE FOREGOING INCLUDING ALL RELIEF OBTAINED BY THE DEBTORS IN THE CHAPTER 11 CASES. FOR THE AVOIDANCE OF DOUBT, THE LBM RELEASED PARTIES, TO THE EXTENT THAT LBM HAS NOT WITHDRAWN FROM THE SETTLEMENT DESCRIBED IN ARTICLE IV.I OF THIS PLAN, SHALL CONSTITUTE RELEASED PARTIES WITH RESPECT TO THIS DEBTOR RELEASE.

NOTWITHSTANDING ANYTHING TO THE CONTRARY IN THE FOREGOING, THE RELEASES SET FORTH ABOVE DO NOT RELEASE: (1) POST-EFFECTIVE DATE OBLIGATIONS OF ANY PARTY OR ENTITY UNDER THE PLAN, THE CONFIRMATION ORDER, ANY WIND DOWN TRANSACTION, OR ANY OTHER DOCUMENT, INSTRUMENT, OR AGREEMENT (INCLUDING THOSE SET FORTH IN THE PLAN SUPPLEMENT) EXECUTED TO IMPLEMENT THE PLAN, INCLUDING THE VIDA EXIT FINANCING FACILITY DOCUMENTS, OR ANY CLAIM OR OBLIGATION ARISING UNDER THE PLAN; (2) THE RIGHTS OF ANY HOLDER OF ALLOWED CLAIMS TO RECEIVE DISTRIBUTIONS UNDER THE PLAN; (3) THE RETAINED CAUSES OF ACTION; (4) ANY CLAIMS RELATED TO ANY ACT OR OMISSION THAT IS DETERMINED IN A FINAL ORDER TO HAVE CONSTITUTED ACTUAL FRAUD, WILLFUL MISCONDUCT, INTENTIONAL BREACH OF FIDUCIARY DUTY, OR GROSS NEGLIGENCE; (5) THE DEBTORS' PREPETITION LEGAL COUNSEL SOLELY WITH RESPECT TO CLAIMS OR CAUSES OF ACTION ARISING FROM SUCH COUNSEL'S PREPETITION ADVICE TO THE DEBTORS AND/OR ANY FORMER DIRECTORS OR OFFICERS OF THE DEBTORS OTHER THAN ADVICE DIRECTLY RELATING TO THE PREPARATION AND FILING OF THE CHAPTER 11 CASES (IT BEING UNDERSTOOD ANY PREPETITION ADVICE TO THE DEBTORS RELATING TO PREPETITION TRANSACTIONS BETWEEN THE DEBTORS AND BENEFICIENT SHALL NOT CONSTITUTE ADVICE DIRECTLY RELATING TO THE PREPARATION AND FILING OF THE CHAPTER 11 CASES); OR (6) ANY NON-RELEASED PARTY.

ENTRY OF THE CONFIRMATION ORDER SHALL CONSTITUTE THE BANKRUPTCY COURT'S APPROVAL, PURSUANT TO BANKRUPTCY RULE 9019, OF THE FOREGOING DEBTOR RELEASE, WHICH INCLUDES BY REFERENCE EACH OF THE RELATED PROVISIONS AND DEFINITIONS CONTAINED IN THE PLAN, AND FURTHER, SHALL CONSTITUTE THE BANKRUPTCY COURT'S FINDING THAT THE DEBTOR RELEASE IS: (A) IN EXCHANGE FOR THE GOOD AND VALUABLE CONSIDERATION PROVIDED BY THE RELEASED PARTIES, INCLUDING, WITHOUT LIMITATION, THE RELEASED PARTIES' CONTRIBUTIONS TO FACILITATING THE WIND DOWN TRANSACTIONS AND IMPLEMENTING THE PLAN; (B) A GOOD FAITH SETTLEMENT AND COMPROMISE OF THE CLAIMS RELEASED BY THE DEBTOR RELEASE; (C) IN

THE BEST INTERESTS OF THE DEBTORS AND ALL HOLDERS OF CLAIMS AND INTERESTS; (D) FAIR, EQUITABLE, AND REASONABLE; (E) GIVEN AND MADE AFTER DUE NOTICE AND OPPORTUNITY FOR HEARING; AND (F) A BAR TO ANY OF THE DEBTORS, THE WIND DOWN DEBTORS, OR THE DEBTORS' ESTATES ASSERTING ANY CLAIM OR CAUSE OF ACTION RELEASED PURSUANT TO THE DEBTOR RELEASE.

The Plan contains certain definitions related to the foregoing release:

“RELEASED PARTY” MEANS, COLLECTIVELY, AND IN EACH CASE IN THEIR RESPECTIVE CAPACITIES AS SUCH AND SUBJECT TO THE LIMITATIONS SET FORTH IN ARTICLE VIII.C HEREOF: (A) (I) THE DEBTORS AND THE WIND DOWN DEBTORS, (II) VIDA, (III) THE BONDHOLDER COMMITTEE AND EACH OF ITS MEMBERS, (IV) ANTHONY R. HORTON, IN HIS CAPACITIES AS AN INDEPENDENT DIRECTOR AND DIRECTOR OF THE DEBTORS, (V) JEFFREY S. STEIN, IN HIS CAPACITIES AS AN OFFICER, AN INDEPENDENT DIRECTOR, AND A DIRECTOR OF THE DEBTORS, (VI) MICHAEL A. TUCKER, IN HIS CAPACITY AS AN OFFICER OF THE DEBTORS, (VII) THE DLP INDEPENDENT DIRECTORS, (VIII) FTI CONSULTING, INC., (IX) PJT PARTNERS LP, AND (X) ANY OTHER PROFESSIONAL RETAINED BY THE DEBTORS, THE INDEPENDENT DIRECTORS, THE DLP INDEPENDENT DIRECTORS, OR THE BONDHOLDER COMMITTEE BY ORDER OF THE BANKRUPTCY COURT IN THE CHAPTER 11 CASES OR ANY PROFESSIONAL RETAINED BY ANY OF THE MEMBERS OF THE BONDHOLDER COMMITTEE, EACH IN SUCH CAPACITY; AND (B) SOLELY TO THE EXTENT AND ON THE TERMS AND CONDITIONS SET FORTH IN THIS PLAN, THE LBM RELEASED PARTIES.

“NON-RELEASED PARTIES” SHALL MEAN ANY ENTITIES THAT ARE NOT RELEASED PARTIES, WHICH ENTITIES SHALL INCLUDE, WITHOUT LIMITATION, BENEFICIENT, ITS CURRENT AND FORMER DIRECTORS AND OFFICERS (INCLUDING, WITHOUT LIMITATION, BRADLEY K. HEPPNER, THOMAS O. HICKS, BRUCE W. SCHNITZER, DENNIS P. LOCKHART, AND PETER T. CANGANY), HCLP NOMINEES, L.L.C., THE DEBTORS' FORMER DIRECTORS AND OFFICERS (INCLUDING, WITHOUT LIMITATION, MURRAY HOLLAND AND TIMOTHY EVANS) IN THEIR CAPACITY OR CAPACITIES AS SUCH, AND ANY ENTITIES AFFILIATED WITH OR OTHERWISE RELATED TO THE FOREGOING.

Article VIII.E of the Plan provides for an exculpation of certain parties (the “**Exculpation**”):

EXCEPT AS OTHERWISE EXPRESSLY STATED IN THIS PLAN OR THE CONFIRMATION ORDER, AS OF THE EFFECTIVE DATE, EACH EXCULPATED PARTY SHALL BE DEEMED TO BE RELEASED AND EXCULPATED FROM ANY CLAIM, OBLIGATION, CAUSE OF ACTION, OR LIABILITY FOR ANY EXCULPATED CLAIM, EXCEPT FOR CLAIMS RELATED TO ANY ACT OR OMISSION THAT IS DETERMINED IN A FINAL ORDER TO HAVE CONSTITUTED INTENTIONAL BREACH OF FIDUCIARY DUTY, ACTUAL FRAUD, WILLFUL MISCONDUCT, OR GROSS NEGLIGENCE, BUT IN ALL RESPECTS EACH DEBTOR

AND EACH EXCULPATED PARTY SHALL BE ENTITLED TO REASONABLY RELY UPON THE ADVICE OF COUNSEL WITH RESPECT TO THEIR DUTIES AND RESPONSIBILITIES PURSUANT TO THE PLAN. THE EXCULPATED PARTIES HAVE, AND UPON THE CONSUMMATION OF THE PLAN, SHALL BE DEEMED TO HAVE, PARTICIPATED IN GOOD FAITH AND IN COMPLIANCE WITH APPLICABLE LAW WITH REGARD TO THE RESTRUCTURING OF CLAIMS AND INTERESTS IN THE CHAPTER 11 CASES AND IN CONNECTION WITH THE WIND DOWN TRANSACTIONS, THE NEGOTIATION, FORMULATION, OR PREPARATION OF THE WIND DOWN DOCUMENTS OR RELATED AGREEMENTS, INSTRUMENTS, OR OTHER DOCUMENTS (INCLUDING, FOR THE AVOIDANCE OF DOUBT, PROVIDING ANY LEGAL OPINION REQUESTED BY ANY ENTITY REGARDING ANY TRANSACTION, CONTRACT, INSTRUMENT, DOCUMENT, OR OTHER AGREEMENT CONTEMPLATED BY THE PLAN OR THE RELIANCE BY ANY RELEASED PARTY ON THE PLAN OR THE CONFIRMATION ORDER IN LIEU OF SUCH LEGAL OPINION) IN CONNECTION WITH THE PLAN, AND THE SOLICITATION OF THE PLAN AND DISTRIBUTIONS PURSUANT TO THE PLAN AND, THEREFORE, ARE NOT, AND ON ACCOUNT OF SUCH DISTRIBUTIONS SHALL NOT BE, LIABLE AT ANY TIME FOR THE VIOLATION OF ANY APPLICABLE LAW, RULE, OR REGULATION GOVERNING THE SOLICITATION OF ACCEPTANCES OR REJECTIONS OF THE PLAN OR SUCH DISTRIBUTIONS MADE PURSUANT TO THE PLAN, EXCEPT FOR CLAIMS RELATED TO ANY ACT OR OMISSION THAT IS DETERMINED IN A FINAL ORDER TO HAVE CONSTITUTED INTENTIONAL BREACH OF FIDUCIARY DUTY, ACTUAL FRAUD, WILLFUL MISCONDUCT, OR GROSS NEGLIGENCE. THE DEBTORS AND THE CREDITOR PROPONENTS AGREE THAT (1) NEITHER THE ACT ITSELF OF FILING OR PROSECUTING A MOTION TO APPROVE A SETTLEMENT OF ANY ESTATE CAUSES OF ACTION WITH BENEFICIENT, ANY OF ITS AFFILIATES OR RELATED PARTIES, AND/OR ANY OTHER NON-RELEASED PARTY NOR THE ACT ITSELF OF FILING OR PROSECUTING ANY OBJECTION TO ANY SUCH SETTLEMENT IN AND OF ITSELF CONSTITUTES AN INTENTIONAL BREACH OF FIDUCIARY DUTY, AND (2) ANY CLAIMS THAT THE DEBTORS OR THE CREDITOR PROPONENTS MAY SEEK TO BRING AGAINST ANY EXCULPATED PARTY SHALL BE LIMITED TO ANY ACTIONS OF SUCH EXCULPATED PARTY SOLELY AFTER THE DATE OF EXECUTION OF THE MEDIATION AGREEMENT; PROVIDED THAT ANY SUCH CLAIMS MUST BE FILED EXCLUSIVELY IN THE BANKRUPTCY COURT AND IN ACCORDANCE WITH THE FEDERAL RULES OF CIVIL PROCEDURES, AND SUCH CLAIMS SHALL BE PLED WITH SPECIFICITY WITH RESPECT TO THE WHO, WHAT, WHEN, WHERE, AND HOW OF THE ALLEGED WRONGFUL CONDUCT.

“EXCULPATED PARTY” MEANS, COLLECTIVELY, AND IN EACH CASE, IN THEIR RESPECTIVE CAPACITIES AS SUCH: (A) JEFFREY S. STEIN, IN HIS CAPACITIES AS AN OFFICER, AN INDEPENDENT DIRECTOR, AND A DIRECTOR OF THE DEBTORS; (B) ANTHONY R. HORTON, IN HIS CAPACITIES AS AN INDEPENDENT DIRECTOR AND DIRECTOR OF THE DEBTORS; (C) MICHAEL A. TUCKER, IN HIS CAPACITY AS AN OFFICER OF THE DEBTORS; (D) THE NON-MANAGEMENT DIRECTORS, IN THEIR CAPACITY AS SUCH; (E) THE DLP INDEPENDENT

DIRECTORS, IN THEIR CAPACITY AS SUCH; (F) THE MEMBERS OF THE BONDHOLDER COMMITTEE, IN THEIR CAPACITY AS SUCH; (G) ANY PROFESSIONAL RETAINED BY THE DEBTORS, THE INDEPENDENT DIRECTORS, THE DLP INDEPENDENT DIRECTORS, THE BONDHOLDER COMMITTEE, IN SUCH PROFESSIONALS' CAPACITY AS SUCH; AND (H) ANY PROFESSIONAL RETAINED BY ANY OF THE MEMBERS OF THE BONDHOLDER COMMITTEE, EACH IN SUCH PROFESSIONALS' CAPACITY AS SUCH.

“EXCULPATED CLAIM” MEANS ANY CLAIM RELATED TO ANY ACT OR OMISSION FROM THE PETITION DATE TO THE EFFECTIVE DATE IN CONNECTION WITH, RELATING TO, OR ARISING OUT OF: (A) THE CHAPTER 11 CASES; (B) THE FORMULATION, PREPARATION, DISSEMINATION, OR NEGOTIATION OF ANY DOCUMENT IN CONNECTION WITH THE CHAPTER 11 CASES; (C) ANY CONTRACT, INSTRUMENT, RELEASE, AND/OR OTHER AGREEMENT OR DOCUMENT CREATED OR ENTERED INTO IN CONNECTION WITH THE CHAPTER 11 CASES; (D) THE PURSUIT OF CONSUMMATION; AND/OR (E) THE FILING, ADMINISTRATION, AND/OR IMPLEMENTATION OF THE CHAPTER 11 CASES, OR THE DISTRIBUTION OF PROPERTY IN CONNECTION THEREWITH OR THEREUNDER; PROVIDED, THAT, FOR THE AVOIDANCE OF DOUBT, ANY PREPETITION ADVICE PROVIDED BY ANY LEGAL PROFESSIONALS IN CONNECTION WITH PREPETITION TRANSACTIONS BETWEEN THE DEBTORS AND BENEFICIENT SHALL NOT CONSTITUTE ANY ACT OR OMISSION THAT IS COVERED BY THIS DEFINITION OF EXCULPATED CLAIM; PROVIDED, FURTHER, THAT, NOTWITHSTANDING THE FOREGOING, EXCULPATED CLAIMS SHALL NOT INCLUDE ANYTHING RELATED TO ANY ACT OR OMISSION THAT IS DETERMINED IN A FINAL ORDER TO HAVE CONSTITUTED ACTUAL FRAUD, WILLFUL MISCONDUCT, INTENTIONAL BREACH OF FIDUCIARY DUTY, OR GROSS NEGLIGENCE.

Article VIII.G of the Plan establishes an injunction (the “Injunction”):

EXCEPT AS OTHERWISE EXPRESSLY PROVIDED IN THE PLAN OR THE CONFIRMATION ORDER OR FOR OBLIGATIONS OR DISTRIBUTIONS REQUIRED TO BE PAID PURSUANT TO THE PLAN OR THE CONFIRMATION ORDER, ALL ENTITIES WHO HAVE HELD, HOLD, OR MAY HOLD CLAIMS THAT HAVE BEEN RELEASED PURSUANT TO ARTICLE VIII HEREOF ARE PERMANENTLY ENJOINED, FROM AND AFTER THE EFFECTIVE DATE, FROM TAKING ANY OF THE FOLLOWING ACTIONS AGAINST, AS APPLICABLE, THE DEBTORS, THE RELEASED PARTIES, OR THE EXCULPATED PARTIES: (1) COMMENCING OR CONTINUING IN ANY MANNER ANY ACTION OR OTHER PROCEEDING OF ANY KIND ON ACCOUNT OF OR IN CONNECTION WITH OR WITH RESPECT TO ANY OF THE CLAIMS OR INTERESTS RELEASED HEREUNDER; (2) ENFORCING, ATTACHING, COLLECTING, OR RECOVERING BY ANY MANNER OR MEANS ANY JUDGMENT, AWARD, DECREE, OR ORDER AGAINST SUCH ENTITIES ON ACCOUNT OR IN CONNECTION WITH OR WITH RESPECT TO ANY CLAIMS OR INTERESTS RELEASED HEREUNDER; (3) CREATING, PERFECTING, OR ENFORCING ANY LIEN OR ENCUMBRANCE OF ANY KIND AGAINST SUCH

ENTITIES OR THE PROPERTY OF SUCH ENTITIES ON ACCOUNT OR IN CONNECTION WITH OR WITH RESPECT TO ANY CLAIMS OR INTERESTS RELEASED HEREUNDER; (4) ASSERTING ANY RIGHT OF SETOFF, SUBROGATION, OR RECOUPMENT OF ANY KIND AGAINST ANY OBLIGATION DUE FROM SUCH ENTITIES OR AGAINST THE PROPERTY OR THE ESTATES OF SUCH ENTITIES ON ACCOUNT OR IN CONNECTION WITH OR WITH RESPECT TO ANY CLAIMS OR INTERESTS RELEASED HEREUNDER, UNLESS SUCH HOLDER HAS FILED A MOTION REQUESTING THE RIGHT TO PERFORM SUCH SETOFF ON OR BEFORE THE EFFECTIVE DATE, AND NOTWITHSTANDING AN INDICATION OF A CLAIM OR INTEREST OR OTHERWISE THAT SUCH HOLDER ASSERTS, HAS, OR INTENDS TO PRESERVE ANY RIGHT OF SETOFF PURSUANT TO APPLICABLE LAW OR OTHERWISE; AND (5) COMMENCING OR CONTINUING IN ANY MANNER ANY ACTION OR OTHER PROCEEDING OF ANY KIND ON ACCOUNT OF OR IN CONNECTION WITH OR WITH RESPECT TO ANY CLAIMS OR INTERESTS RELEASED OR SETTLED PURSUANT TO THIS PLAN.

UPON ENTRY OF THE CONFIRMATION ORDER, ALL HOLDERS OF CLAIMS AND INTERESTS AND THEIR RESPECTIVE CURRENT AND FORMER EMPLOYEES, AGENTS, OFFICERS, DIRECTORS, PRINCIPALS, AND DIRECT AND INDIRECT AFFILIATES SHALL BE ENJOINED FROM TAKING ANY ACTIONS TO INTERFERE WITH THE IMPLEMENTATION OR CONSUMMATION OF THIS PLAN. EXCEPT AS OTHERWISE SET FORTH IN THE CONFIRMATION ORDER, EACH HOLDER OF AN ALLOWED CLAIM OR ALLOWED INTEREST, AS APPLICABLE, BY ACCEPTING, OR BEING ELIGIBLE TO ACCEPT, DISTRIBUTIONS UNDER THIS PLAN SHALL BE DEEMED TO HAVE CONSENTED TO THE INJUNCTION PROVISIONS SET FORTH HEREIN.

PLEASE SUBMIT YOUR MASTER BALLOT PROMPTLY

IF YOU HAVE ANY QUESTIONS REGARDING THIS BALLOT, THESE VOTING INSTRUCTIONS, OR THE PROCEDURES FOR VOTING, PLEASE CALL THE SOLICITATION AGENT AT:

U.S. TOLL FREE: (888) 508-2507

OR EMAIL GWGINFO@DONLINRECANO.COM

**Schedule 1
Bond CUSIPs**

36192AAR0	36250CEY6	36251N2G3	36251NCZ0	36251NFM6	36251NMS5
36192AAS8	36250CEZ3	36251N2H1	36251ND30	36251NFQ7	36251NMT3
36250CDA9	36250CFA7	36251N2K4	36251ND48	36251NFR5	36251NMTU0
36250CDB7	36250CFB5	36251N2L2	36251ND55	36251NFU8	36251NMTV8
36250CDC5	36250CFC3	36251N2M0	36251ND71	36251NFV6	36251NMTW6
36250CDD3	36250CFD1	36251N2P3	36251ND89	36251NFY0	36251NMX4
36250CDE1	36250CFE9	36251N2Q1	36251ND97	36251NFZ7	36251NMY2
36250CDF8	36250CFF6	36251N2R9	36251NDC0	36251NG37	36251NMTZ9
36250CDG6	36250CFG4	36251N2T5	36251NDD8	36251NG45	36251NN21
36250CDH4	36250CFH2	36251N2U2	36251NDG1	36251NG52	36251NN39
36250CDJ0	36250CFJ8	36251N2V0	36251NDH9	36251NGC7	36251NN47
36250CDK7	36250CFK5	36251N2X6	36251NDL0	36251NGD5	36251NN54
36250CDL5	36250CFL3	36251N2Y4	36251NDM8	36251NGG8	36251NN62
36250CDM3	36250CFM1	36251N2Z1	36251NDQ9	36251NGH6	36251NN70
36250CDN1	36250CFN9	36251N3B3	36251NDR7	36251NGL7	36251NN88
36250CDP6	36250CFP4	36251N3C1	36251NDU0	36251NGM5	36251NN96
36250CDQ4	36250CFQ2	36251N3D9	36251NDV8	36251NGQ6	36251NNA3
36250CDR2	36250CFR0	36251N3F4	36251NDY2	36251NGR4	36251NNB1
36250CDS0	36250CFS8	36251N3G2	36251NDZ9	36251NGU7	36251NNC9
36250CDT8	36250CFT6	36251N3H0	36251NE39	36251NGV5	36251NND7
36250CDU5	36250CFU3	36251N3K3	36251NE47	36251NGY9	
36250CDV3	36250CFV1	36251N3L1	36251NE54	36251NGZ6	
36250CDW1	36250CFW9	36251N3M9	36251NE70	36251NHC6	
36250CDX9	36250CFX7	36251N4A4	36251NE88	36251NHD4	
36250CDY7	36250CFY5	36251N4B2	36251NE96	36251NHG7	
36250CDZ4	36250CFZ2	36251N4C0	36251NEC9	36251NHH5	
36250CEA8	36250CGA6	36251N4D8	36251NED7	36251NHL6	
36250CEB6	36250CGB4	36251N4E6	36251NEG0	36251NHM4	
36250CEC4	36250CGC2	36251N4F3	36251NEH8	36251NHQ5	
36250CED2	36250CGD0	36251N4G1	36251NEL9	36251NHR3	
36250CEE0	36250CGE8	36251N4H9	36251NEM7	36251NHU6	
36250CEF7	36250CGF5	36251N4J5	36251NEQ8	36251NHV4	
36250CEG5	36250CGG3	36251N4K2	36251NER6	36251NHY8	
36250CEH3	36250CGH1	36251N4L0	36251NEU9	36251NHZ5	
36250CEJ9	36250CJS4	36251N4M8	36251NEV7	36251NJC4	
36250CEK6	36250CJT2	36251N4N6	36251NEY1	36251NJD2	
36250CEL4	36250CJV7	36251N4P1	36251NEZ8	36251NME6	
36250CEM2	36250CJW5	36251N4Q9	36251NF38	36251NMF3	
36250CEN0	36250CJX3	36251N4R7	36251NF46	36251NMG1	
36250CEP5	36250CJY1	36251NB73	36251NF53	36251NMH9	
36250CEQ3	36250CJZ8	36251NB81	36251NF79	36251NMJ5	
36250CER1	36250CKA1	36251NB99	36251NF87	36251NMK2	
36250CES9	36250CKB9	36251NC31	36251NF95	36251NML0	
36250CET7	36250CKC7	36251NC49	36251NFC8	36251NMM8	
36250CEU4	36250CKD5	36251NC56	36251NFD6	36251NMN6	
36250CEV2	36251N2C2	36251NC72	36251NFG9	36251NMP1	
36250CEW0	36251N2D0	36251NC80	36251NFH7	36251NMQ9	
36250CEX8	36251N2F5	36251NC98	36251NFL8	36251NMR7	

Exhibit 3C

Class 3 Bond Claims - Beneficial Holder Ballot

**IN THE UNITED STATES BANKRUPTCY COURT
FOR THE SOUTHERN DISTRICT OF TEXAS
HOUSTON DIVISION**

In re:)	
)	Chapter 11
GWG Holdings, Inc., <i>et al.</i> , ¹)	Case No. 22-90032 (MI)
Debtors.)	(Jointly Administered)

**BENEFICIAL HOLDER BALLOT FOR VOTING TO ACCEPT OR REJECT
THE DEBTORS' SECOND AMENDED JOINT CHAPTER 11 PLAN**

Class 3: Bond Claims (Indirect-Held)

PLEASE READ AND FOLLOW THE ENCLOSED INSTRUCTIONS FOR COMPLETING BALLOTS CAREFULLY BEFORE COMPLETING THIS BALLOT.

FOR YOUR VOTE TO BE COUNTED, THIS BALLOT MUST BE COMPLETED, EXECUTED, AND RETURNED SO AS TO BE ACTUALLY RECEIVED BY THE SOLICITATION AGENT BY MAY 31, 2023 AT 4:00 P.M. (PREVAILING CENTRAL TIME) THE ("VOTING DEADLINE"). IF THIS BALLOT IS NOT PROPERLY COMPLETED, EXECUTED, AND RECEIVED BY THE SOLICITATION AGENT ON OR BEFORE THE VOTING DEADLINE, THEN THE VOTES TRANSMITTED BY THIS BALLOT WILL NOT BE COUNTED.

ACCESS TO SOLICITATION MATERIALS:

THE PLAN, DISCLOSURE STATEMENT AND DISCLOSURE STATEMENT ORDER, INCLUDING THE SOLICITATION PROCEDURES AND THE BONDHOLDER SUMMARY MAY BE ACCESSED FREE OF CHARGE AT [HTTPS://WWW.DONLINRECANO.COM/CLIENTS/GWG/INDEX](https://www.donlinrecano.com/clients/gwg/index) BY CLICKING ON THE "SOLICITATION MATERIALS" LINK ON THE WEBSITE'S LEFT HAND NAVIGATION PANEL.

YOU CAN ALSO OBTAIN COPIES IN PAPER FORMAT OF ANY SOLICITATION MATERIALS (A) FREE OF CHARGE BY (I) ACCESSING THE DEBTORS' RESTRUCTURING WEBSITE AT

¹ The Debtors in these chapter 11 cases, along with the last four digits of each Debtor's federal tax identification number, are: GWG Holdings, Inc. (2607); GWG Life, LLC (6955); GWG Life USA, LLC (5538) GWG DLP Funding IV, LLC (2598); GWG DLP Funding VI, LLC (6955) and GWG DLP Funding Holdings VI, LLC (6955). The location of Debtor GWG Holdings, Inc.'s principal place of business and the Debtors' service address is 325 N. St. Paul Street, Suite 2650, Dallas, TX 75201. Further information regarding the Debtors and these chapter 11 cases is available at the website of the Debtors' claims and noticing agent: <https://donlinrecano.com/gwg>.

[HTTPS://WWW.DONLINRECANO.COM/CLIENTS/GWG/INDEX](https://www.donlinrecano.com/clients/gwg/index); (II) WRITING TO DONLIN, RECANO & COMPANY, INC., RE: GWG HOLDINGS, INC., ET AL., P.O. BOX 199043, BLYTHEBOURNE STATION, BROOKLYN, NY 11219; (III) CALLING 1 (888) 508-2507 (U.S. TOLL FREE); OR (IV) EMAILING GWGINFO@DONLINRECANO.COM; OR (B) FOR A FEE VIA PACER AT [HTTPS://ECF.TXSB.USCOURTS.GOV/](https://ecf.txsb.uscourts.gov/).

Solicitation Overview

The above-captioned debtors and debtors in possession (collectively, the “Debtors”), are soliciting votes with respect to the Plan as set forth in the *Disclosure Statement for the Debtors’ Second Amended Joint Chapter 11 Plan* [Docket No. 1682] (as may be amended, supplemented, or modified, the “Disclosure Statement”) and the *Debtors’ Second Amended Joint Chapter 11 Plan* [Docket No. 1678] (as may be amended, supplemented, or modified, the “Plan”).² The Bankruptcy Court for the Southern District of Texas (the “Court”) has approved the Disclosure Statement as containing adequate information pursuant to section 1125 of the Bankruptcy Code, by entry of an order on April 21, 2023 [Docket No. 1681³] (the “Disclosure Statement Order”). Court approval of the Disclosure Statement does not indicate approval of the Plan by the Court.

Your rights are described in the Plan, the Disclosure Statement, and the related materials. If you would like paper copies of the Plan, Disclosure Statement and other Solicitation Materials, or if you need to obtain additional Solicitation Packages, you may obtain them (a) at no charge from Donlin Recano & Company, Inc. (the “Solicitation Agent”) by: (i) accessing the Debtors’ restructuring website at <https://www.donlinrecano.com/Clients/gwg/Index>; (ii) calling 1 (888) 508-2507 (U.S. toll-free) or (iii) emailing gwginfo@donlinrecano.com; or (b) for a fee via PACER at <https://ecf.txsb.uscourts.gov/>.

You are receiving this ballot (the “Ballot”) because records indicate that, as of February 24, 2023 (the “Voting Record Date”), you are the Beneficial Holder of an Allowed Class 3 Bond Claim, or an assignee or transferee thereof. Accordingly, you have a right to vote to accept or reject the Plan. As set forth in the Disclosure Statement, the Debtors, the Bondholder Committee, LBM, and the Ad Hoc Committee of Broker/Dealers recommend that you vote to **ACCEPT** the Plan.

If the Plan is confirmed by the Court, it will be binding on you regardless of whether or not you vote or whether you vote to accept or reject the Plan. To have your vote counted, you must complete, sign, and return this Ballot pursuant to the instructions provided by your Nominee so that it is received by the Solicitation Agent no later than the Voting Deadline.

This Ballot may not be used for any purpose other than for casting votes to accept or reject the Plan and making certain certifications with respect to the Plan. If you believe you have received this Ballot in error, or if you believe you have received the wrong ballot, please contact the Solicitation Agent immediately at the address, telephone number, or email address set forth above.

² Capitalized terms used but not otherwise defined herein shall have the meanings ascribed to such terms in the Plan, the Disclosure Statement, or the Disclosure Statement Order, as applicable.

³ As modified pursuant to the order entered at docket 1692.

The above information is a simplified summary of certain aspects of the Plan for informational purposes only and should not be relied upon. *You should carefully and thoroughly review the Disclosure Statement and Plan before you vote to accept or reject the Plan. You may wish to seek legal advice concerning the Plan and classification and treatment of your Claim under the Plan.*

Releases

ARTICLE VIII OF THE PLAN CONTAINS RELEASE, EXCULPATION, AND INJUNCTION PROVISIONS.

Item 1. Voting - Complete This Section.

ITEM 1: PRINCIPAL AMOUNT OF CLAIMS	<p>The undersigned hereby certifies that, as of the Voting Record Date, the undersigned was the Beneficial Holder (or authorized signatory for a Beneficial Holder), of Claim(s) in the Voting Class as set forth below (your “Claims”). You may vote to accept or reject the Plan. You must check the applicable box in the right-hand column below to “accept” or “reject” the Plan for the Voting Class in order to have your vote in the Voting Class counted.</p> <p>Please note that you are voting all of your Claims in the Voting Class either to accept or reject the Plan. You may not split your vote in the Voting Class. If you do not indicate that you either accept or reject the Plan in the Voting Class by checking the applicable box below, your vote in the Voting Class will not be counted. If you indicate that you both accept and reject the Plan for the Voting Class your vote in the Voting Class will not be counted.</p> <p>The Beneficial Holder of the Claim(s) in the Voting Classes set forth below votes to:</p>		
Voting Class	Description	Amount	Vote to accept or reject the Plan:
Class 3	Bond Claims CUSIP: [_____]	\$_____	<input type="checkbox"/> ACCEPT (VOTE FOR) THE PLAN <input type="checkbox"/> REJECT (VOTE AGAINST) THE PLAN

The above amount may not be the same as the amount you included in a filed Proof of Claim, and the above amount excludes accrued interest solely for voting tabulation purposes. The submission of this Ballot with respect to the above amount is without prejudice to the resolution of the allowance of your Claim, which will ultimately include principal on the Bonds plus accrued unpaid interest through April 20, 2022.

Item 2. Important information regarding the release, exculpation, and injunction provisions in the Plan.⁴

Article VIII.C of the Plan contains the following release (the “**Release**”):

PURSUANT TO SECTION 1123(B) OF THE BANKRUPTCY CODE, IN EXCHANGE FOR GOOD AND VALUABLE CONSIDERATION, THE ADEQUACY OF WHICH IS HEREBY CONFIRMED, ON AND AFTER THE EFFECTIVE DATE, EACH RELEASED PARTY (BUT NO NON-RELEASED PARTY) IS, AND IS DEEMED HEREBY TO BE, FULLY, CONCLUSIVELY, ABSOLUTELY, UNCONDITIONALLY, IRREVOCABLY, AND FOREVER RELEASED AND DISCHARGED BY THE DEBTORS, THE WIND DOWN DEBTORS, AND THEIR ESTATES, AND ANY PERSON SEEKING TO EXERCISE THE RIGHTS OF THE DEBTORS OR THEIR ESTATES, INCLUDING ANY SUCCESSORS TO THE DEBTORS OR ANY ESTATES REPRESENTATIVES APPOINTED OR SELECTED PURSUANT TO SECTION 1123(B)(3) OF THE BANKRUPTCY CODE, IN EACH CASE ON BEHALF OF THEMSELVES AND THEIR RESPECTIVE SUCCESSORS, ASSIGNS, AND REPRESENTATIVES, AND ANY AND ALL OTHER ENTITIES WHO MAY PURPORT TO ASSERT ANY CAUSE OF ACTION, DIRECTLY OR DERIVATIVELY, BY, THROUGH OR FOR THE DEBTORS OR THEIR ESTATES, FROM ANY AND ALL CLAIMS AND CAUSES OF ACTION, WHETHER KNOWN OR UNKNOWN, INCLUDING ANY DERIVATIVE CLAIMS, ASSERTED OR ASSERTABLE ON BEHALF OF THE DEBTORS, WHETHER KNOWN OR UNKNOWN, FORESEEN OR UNFORESEEN, MATURED OR UNMATURED, EXISTING OR HEREAFTER ARISING, CONTINGENT OR NON-CONTINGENT, IN LAW, EQUITY, CONTRACT, TORT OR OTHERWISE, EXCEPT FOR ANY CLAIMS RELATED TO ANY ACT OR OMISSION THAT IS DETERMINED IN A FINAL ORDER TO HAVE CONSTITUTED ACTUAL FRAUD, WILLFUL MISCONDUCT, INTENTIONAL BREACH OF FIDUCIARY DUTY, OR GROSS NEGLIGENCE, THAT THE DEBTORS, THE WIND DOWN DEBTORS, OR THEIR ESTATES, INCLUDING ANY SUCCESSORS TO THE DEBTORS OR ANY ESTATES REPRESENTATIVE APPOINTED OR SELECTED PURSUANT TO SECTION 1123(B) OF THE BANKRUPTCY CODE, WOULD HAVE BEEN LEGALLY ENTITLED TO ASSERT IN THEIR OWN RIGHT (WHETHER INDIVIDUALLY OR COLLECTIVELY) OR ON BEHALF OF THE HOLDER OF ANY CLAIM OR INTEREST IN, A DEBTOR OR OTHER ENTITY, OR THAT ANY HOLDER OF ANY CLAIM AGAINST, OR INTEREST IN, A DEBTOR OR OTHER ENTITY COULD HAVE ASSERTED ON BEHALF OF THE DEBTORS, BASED ON OR RELATING TO, OR IN ANY MANNER ARISING FROM, IN WHOLE OR IN PART, THE DEBTORS (INCLUDING THE CAPITAL STRUCTURE, MANAGEMENT, OWNERSHIP OR OPERATION THEREOF), THE BUSINESS OR CONTRACTUAL ARRANGEMENT BETWEEN THE DEBTORS AND ANY RELEASED PARTY, ANY SECURITIES ISSUED BY THE DEBTORS AND THE OWNERSHIP THEREOF, THE ASSERTION OR ENFORCEMENT OF RIGHTS AND REMEDIES AGAINST THE DEBTORS, THE DEBTORS’ IN- OR OUT-OF-COURT RESTRUCTURING EFFORTS,

⁴ The Plan provisions referenced herein are for summary purposes only and do not include all provisions of the Plan that may affect your rights. If there is any inconsistency between the provisions set forth herein and the Plan, the Plan governs. You should read the Plan before completing this Ballot.

ANY AVOIDANCE ACTIONS (BUT EXCLUDING AVOIDANCE ACTIONS BROUGHT AS COUNTERCLAIMS OR DEFENSES TO CLAIMS ASSERTED AGAINST THE DEBTORS), INTERCOMPANY TRANSACTIONS BETWEEN OR AMONG A DEBTOR AND ANOTHER DEBTOR, THE FORMULATION, PREPARATION, DISSEMINATION, NEGOTIATION, OR FILING OF THE DISCLOSURE STATEMENT, THE PLAN (INCLUDING, FOR THE AVOIDANCE OF DOUBT, THE PLAN SUPPLEMENT), THE VIDA DIP FINANCING FACILITY, THE VIDA EXIT FINANCING FACILITY, OR ANY WIND DOWN TRANSACTION, CONTRACT, INSTRUMENT, RELEASE, OR OTHER AGREEMENT OR DOCUMENT (INCLUDING ANY LEGAL OPINION REQUESTED BY ANY ENTITY REGARDING ANY TRANSACTION, CONTRACT, INSTRUMENT, DOCUMENT OR OTHER AGREEMENT CONTEMPLATED BY THE PLAN OR THE RELIANCE BY ANY RELEASED PARTY ON THE PLAN OR THE CONFIRMATION ORDER IN LIEU OF SUCH LEGAL OPINION) CREATED OR ENTERED INTO IN CONNECTION WITH THE DISCLOSURE STATEMENT, THE VIDA EXIT FINANCING FACILITY DOCUMENTS, THE PLAN, OR THE PLAN SUPPLEMENT, BEFORE OR DURING THE CHAPTER 11 CASES, THE CHAPTER 11 CASES, THE FILING OF THE CHAPTER 11 CASES, THE PURSUIT OF CONFIRMATION, THE ADMINISTRATION AND IMPLEMENTATION OF THE PLAN, INCLUDING THE ISSUANCE OR DISTRIBUTION OF SECURITIES PURSUANT TO THE PLAN, OR THE DISTRIBUTION OF PROPERTY UNDER THE PLAN, OR UPON ANY RELATED ACT OR OMISSION, TRANSACTION, AGREEMENT, EVENT, OR OTHER OCCURRENCE RELATED OR RELATING TO ANY OF THE FOREGOING TAKING PLACE ON OR BEFORE THE EFFECTIVE DATE RELATED OR RELATING TO THE FOREGOING INCLUDING ALL RELIEF OBTAINED BY THE DEBTORS IN THE CHAPTER 11 CASES. FOR THE AVOIDANCE OF DOUBT, THE LBM RELEASED PARTIES, TO THE EXTENT THAT LBM HAS NOT WITHDRAWN FROM THE SETTLEMENT DESCRIBED IN ARTICLE IV.I OF THIS PLAN, SHALL CONSTITUTE RELEASED PARTIES WITH RESPECT TO THIS DEBTOR RELEASE.

NOTWITHSTANDING ANYTHING TO THE CONTRARY IN THE FOREGOING, THE RELEASES SET FORTH ABOVE DO NOT RELEASE: (1) POST-EFFECTIVE DATE OBLIGATIONS OF ANY PARTY OR ENTITY UNDER THE PLAN, THE CONFIRMATION ORDER, ANY WIND DOWN TRANSACTION, OR ANY OTHER DOCUMENT, INSTRUMENT, OR AGREEMENT (INCLUDING THOSE SET FORTH IN THE PLAN SUPPLEMENT) EXECUTED TO IMPLEMENT THE PLAN, INCLUDING THE VIDA EXIT FINANCING FACILITY DOCUMENTS, OR ANY CLAIM OR OBLIGATION ARISING UNDER THE PLAN; (2) THE RIGHTS OF ANY HOLDER OF ALLOWED CLAIMS TO RECEIVE DISTRIBUTIONS UNDER THE PLAN; (3) THE RETAINED CAUSES OF ACTION; (4) ANY CLAIMS RELATED TO ANY ACT OR OMISSION THAT IS DETERMINED IN A FINAL ORDER TO HAVE CONSTITUTED ACTUAL FRAUD, WILLFUL MISCONDUCT, INTENTIONAL BREACH OF FIDUCIARY DUTY, OR GROSS NEGLIGENCE; (5) THE DEBTORS' PREPETITION LEGAL COUNSEL SOLELY WITH RESPECT TO CLAIMS OR CAUSES OF ACTION ARISING FROM SUCH COUNSEL'S PREPETITION ADVICE TO THE DEBTORS AND/OR ANY FORMER DIRECTORS OR OFFICERS OF THE DEBTORS OTHER THAN ADVICE DIRECTLY RELATING TO THE PREPARATION AND FILING OF THE CHAPTER 11 CASES (IT BEING UNDERSTOOD ANY PREPETITION ADVICE

TO THE DEBTORS RELATING TO PREPETITION TRANSACTIONS BETWEEN THE DEBTORS AND BENEFICIENT SHALL NOT CONSTITUTE ADVICE DIRECTLY RELATING TO THE PREPARATION AND FILING OF THE CHAPTER 11 CASES); OR (6) ANY NON-RELEASED PARTY.

ENTRY OF THE CONFIRMATION ORDER SHALL CONSTITUTE THE BANKRUPTCY COURT'S APPROVAL, PURSUANT TO BANKRUPTCY RULE 9019, OF THE FOREGOING DEBTOR RELEASE, WHICH INCLUDES BY REFERENCE EACH OF THE RELATED PROVISIONS AND DEFINITIONS CONTAINED IN THE PLAN, AND FURTHER, SHALL CONSTITUTE THE BANKRUPTCY COURT'S FINDING THAT THE DEBTOR RELEASE IS: (A) IN EXCHANGE FOR THE GOOD AND VALUABLE CONSIDERATION PROVIDED BY THE RELEASED PARTIES, INCLUDING, WITHOUT LIMITATION, THE RELEASED PARTIES' CONTRIBUTIONS TO FACILITATING THE WIND DOWN TRANSACTIONS AND IMPLEMENTING THE PLAN; (B) A GOOD FAITH SETTLEMENT AND COMPROMISE OF THE CLAIMS RELEASED BY THE DEBTOR RELEASE; (C) IN THE BEST INTERESTS OF THE DEBTORS AND ALL HOLDERS OF CLAIMS AND INTERESTS; (D) FAIR, EQUITABLE, AND REASONABLE; (E) GIVEN AND MADE AFTER DUE NOTICE AND OPPORTUNITY FOR HEARING; AND (F) A BAR TO ANY OF THE DEBTORS, THE WIND DOWN DEBTORS, OR THE DEBTORS' ESTATES ASSERTING ANY CLAIM OR CAUSE OF ACTION RELEASED PURSUANT TO THE DEBTOR RELEASE.

"RELEASED PARTY" MEANS, COLLECTIVELY, AND IN EACH CASE IN THEIR RESPECTIVE CAPACITIES AS SUCH AND SUBJECT TO THE LIMITATIONS SET FORTH IN ARTICLE VIII.C HEREOF: (A) (I) THE DEBTORS AND THE WIND DOWN DEBTORS, (II) VIDA, (III) THE BONDHOLDER COMMITTEE AND EACH OF ITS MEMBERS, (IV) ANTHONY R. HORTON, IN HIS CAPACITIES AS AN INDEPENDENT DIRECTOR AND DIRECTOR OF THE DEBTORS, (V) JEFFREY S. STEIN, IN HIS CAPACITIES AS AN OFFICER, AN INDEPENDENT DIRECTOR, AND A DIRECTOR OF THE DEBTORS, (VI) MICHAEL A. TUCKER, IN HIS CAPACITY AS AN OFFICER OF THE DEBTORS, (VII) THE DLP INDEPENDENT DIRECTORS, (VIII) FTI CONSULTING, INC., (IX) PJT PARTNERS LP, AND (X) ANY OTHER PROFESSIONAL RETAINED BY THE DEBTORS, THE INDEPENDENT DIRECTORS, THE DLP INDEPENDENT DIRECTORS, OR THE BONDHOLDER COMMITTEE BY ORDER OF THE BANKRUPTCY COURT IN THE CHAPTER 11 CASES OR ANY PROFESSIONAL RETAINED BY ANY OF THE MEMBERS OF THE BONDHOLDER COMMITTEE, EACH IN SUCH CAPACITY; AND (B) SOLELY TO THE EXTENT AND ON THE TERMS AND CONDITIONS SET FORTH IN THIS PLAN, THE LBM RELEASED PARTIES.

"NON-RELEASED PARTIES" SHALL MEAN ANY ENTITIES THAT ARE NOT RELEASED PARTIES, WHICH ENTITIES SHALL INCLUDE, WITHOUT LIMITATION, BENEFICIENT, ITS CURRENT AND FORMER DIRECTORS AND OFFICERS (INCLUDING, WITHOUT LIMITATION, BRADLEY K. HEPPNER, THOMAS O. HICKS, BRUCE W. SCHNITZER, DENNIS P. LOCKHART, AND PETER T. CANGANY), HCLP NOMINEES, L.L.C., THE DEBTORS' FORMER DIRECTORS

AND OFFICERS (INCLUDING, WITHOUT LIMITATION, MURRAY HOLLAND AND TIMOTHY EVANS) IN THEIR CAPACITY OR CAPACITIES AS SUCH, AND ANY ENTITIES AFFILIATED WITH OR OTHERWISE RELATED TO THE FOREGOING.

Article VIII.E of the Plan provides for an exculpation of certain parties (the “**Exculpation**”):

EXCEPT AS OTHERWISE EXPRESSLY STATED IN THIS PLAN OR THE CONFIRMATION ORDER, AS OF THE EFFECTIVE DATE, EACH EXCULPATED PARTY SHALL BE DEEMED TO BE RELEASED AND EXCULPATED FROM ANY CLAIM, OBLIGATION, CAUSE OF ACTION, OR LIABILITY FOR ANY EXCULPATED CLAIM, EXCEPT FOR CLAIMS RELATED TO ANY ACT OR OMISSION THAT IS DETERMINED IN A FINAL ORDER TO HAVE CONSTITUTED INTENTIONAL BREACH OF FIDUCIARY DUTY, ACTUAL FRAUD, WILLFUL MISCONDUCT, OR GROSS NEGLIGENCE, BUT IN ALL RESPECTS EACH DEBTOR AND EACH EXCULPATED PARTY SHALL BE ENTITLED TO REASONABLY RELY UPON THE ADVICE OF COUNSEL WITH RESPECT TO THEIR DUTIES AND RESPONSIBILITIES PURSUANT TO THE PLAN. THE EXCULPATED PARTIES HAVE, AND UPON THE CONSUMMATION OF THE PLAN, SHALL BE DEEMED TO HAVE, PARTICIPATED IN GOOD FAITH AND IN COMPLIANCE WITH APPLICABLE LAW WITH REGARD TO THE RESTRUCTURING OF CLAIMS AND INTERESTS IN THE CHAPTER 11 CASES AND IN CONNECTION WITH THE WIND DOWN TRANSACTIONS, THE NEGOTIATION, FORMULATION, OR PREPARATION OF THE WIND DOWN DOCUMENTS OR RELATED AGREEMENTS, INSTRUMENTS, OR OTHER DOCUMENTS (INCLUDING, FOR THE AVOIDANCE OF DOUBT, PROVIDING ANY LEGAL OPINION REQUESTED BY ANY ENTITY REGARDING ANY TRANSACTION, CONTRACT, INSTRUMENT, DOCUMENT, OR OTHER AGREEMENT CONTEMPLATED BY THE PLAN OR THE RELIANCE BY ANY RELEASED PARTY ON THE PLAN OR THE CONFIRMATION ORDER IN LIEU OF SUCH LEGAL OPINION) IN CONNECTION WITH THE PLAN, AND THE SOLICITATION OF THE PLAN AND DISTRIBUTIONS PURSUANT TO THE PLAN AND, THEREFORE, ARE NOT, AND ON ACCOUNT OF SUCH DISTRIBUTIONS SHALL NOT BE, LIABLE AT ANY TIME FOR THE VIOLATION OF ANY APPLICABLE LAW, RULE, OR REGULATION GOVERNING THE SOLICITATION OF ACCEPTANCES OR REJECTIONS OF THE PLAN OR SUCH DISTRIBUTIONS MADE PURSUANT TO THE PLAN, EXCEPT FOR CLAIMS RELATED TO ANY ACT OR OMISSION THAT IS DETERMINED IN A FINAL ORDER TO HAVE CONSTITUTED INTENTIONAL BREACH OF FIDUCIARY DUTY, ACTUAL FRAUD, WILLFUL MISCONDUCT, OR GROSS NEGLIGENCE. THE DEBTORS AND THE CREDITOR PROPONENTS AGREE THAT (1) NEITHER THE ACT ITSELF OF FILING OR PROSECUTING A MOTION TO APPROVE A SETTLEMENT OF ANY ESTATE CAUSES OF ACTION WITH BENEFICIENT, ANY OF ITS AFFILIATES OR RELATED PARTIES, AND/OR ANY OTHER NON-RELEASED PARTY NOR THE ACT ITSELF OF FILING OR PROSECUTING ANY OBJECTION TO ANY SUCH SETTLEMENT IN AND OF ITSELF CONSTITUTES AN INTENTIONAL BREACH OF FIDUCIARY DUTY, AND (2) ANY CLAIMS THAT THE DEBTORS OR THE CREDITOR PROPONENTS MAY SEEK TO BRING AGAINST ANY EXCULPATED PARTY SHALL BE LIMITED TO ANY ACTIONS OF SUCH EXCULPATED PARTY

SOLELY AFTER THE DATE OF EXECUTION OF THE MEDIATION AGREEMENT; PROVIDED THAT ANY SUCH CLAIMS MUST BE FILED EXCLUSIVELY IN THE BANKRUPTCY COURT AND IN ACCORDANCE WITH THE FEDERAL RULES OF CIVIL PROCEDURES, AND SUCH CLAIMS SHALL BE PLED WITH SPECIFICITY WITH RESPECT TO THE WHO, WHAT, WHEN, WHERE, AND HOW OF THE ALLEGED WRONGFUL CONDUCT.

“EXCULPATED PARTY” MEANS, COLLECTIVELY, AND IN EACH CASE, IN THEIR RESPECTIVE CAPACITIES AS SUCH: (A) JEFFREY S. STEIN, IN HIS CAPACITIES AS AN OFFICER, AN INDEPENDENT DIRECTOR, AND A DIRECTOR OF THE DEBTORS; (B) ANTHONY R. HORTON, IN HIS CAPACITIES AS AN INDEPENDENT DIRECTOR AND DIRECTOR OF THE DEBTORS; (C) MICHAEL A. TUCKER, IN HIS CAPACITY AS AN OFFICER OF THE DEBTORS; (D) THE NON-MANAGEMENT DIRECTORS, IN THEIR CAPACITY AS SUCH; (E) THE DLP INDEPENDENT DIRECTORS, IN THEIR CAPACITY AS SUCH; (F) THE MEMBERS OF THE BONDHOLDER COMMITTEE, IN THEIR CAPACITY AS SUCH; (G) ANY PROFESSIONAL RETAINED BY THE DEBTORS, THE INDEPENDENT DIRECTORS, THE DLP INDEPENDENT DIRECTORS, THE BONDHOLDER COMMITTEE, IN SUCH PROFESSIONALS’ CAPACITY AS SUCH; AND (H) ANY PROFESSIONAL RETAINED BY ANY OF THE MEMBERS OF THE BONDHOLDER COMMITTEE, EACH IN SUCH PROFESSIONALS’ CAPACITY AS SUCH.

“EXCULPATED CLAIM” MEANS ANY CLAIM RELATED TO ANY ACT OR OMISSION FROM THE PETITION DATE TO THE EFFECTIVE DATE IN CONNECTION WITH, RELATING TO, OR ARISING OUT OF: (A) THE CHAPTER 11 CASES; (B) THE FORMULATION, PREPARATION, DISSEMINATION, OR NEGOTIATION OF ANY DOCUMENT IN CONNECTION WITH THE CHAPTER 11 CASES; (C) ANY CONTRACT, INSTRUMENT, RELEASE, AND/OR OTHER AGREEMENT OR DOCUMENT CREATED OR ENTERED INTO IN CONNECTION WITH THE CHAPTER 11 CASES; (D) THE PURSUIT OF CONSUMMATION; AND/OR (E) THE FILING, ADMINISTRATION, AND/OR IMPLEMENTATION OF THE CHAPTER 11 CASES, OR THE DISTRIBUTION OF PROPERTY IN CONNECTION THEREWITH OR THEREUNDER; PROVIDED, THAT, FOR THE AVOIDANCE OF DOUBT, ANY PREPETITION ADVICE PROVIDED BY ANY LEGAL PROFESSIONALS IN CONNECTION WITH PREPETITION TRANSACTIONS BETWEEN THE DEBTORS AND BENEFICIENT SHALL NOT CONSTITUTE ANY ACT OR OMISSION THAT IS COVERED BY THIS DEFINITION OF EXCULPATED CLAIM; PROVIDED, FURTHER, THAT, NOTWITHSTANDING THE FOREGOING, EXCULPATED CLAIMS SHALL NOT INCLUDE ANYTHING RELATED TO ANY ACT OR OMISSION THAT IS DETERMINED IN A FINAL ORDER TO HAVE CONSTITUTED ACTUAL FRAUD, WILLFUL MISCONDUCT, INTENTIONAL BREACH OF FIDUCIARY DUTY, OR GROSS NEGLIGENCE.

Article VIII.G of the Plan establishes an injunction (the “**Injunction**”):

EXCEPT AS OTHERWISE EXPRESSLY PROVIDED IN THE PLAN OR THE CONFIRMATION ORDER OR FOR OBLIGATIONS OR DISTRIBUTIONS REQUIRED

TO BE PAID PURSUANT TO THE PLAN OR THE CONFIRMATION ORDER, ALL ENTITIES WHO HAVE HELD, HOLD, OR MAY HOLD CLAIMS THAT HAVE BEEN RELEASED PURSUANT TO ARTICLE VIII HEREOF ARE PERMANENTLY ENJOINED, FROM AND AFTER THE EFFECTIVE DATE, FROM TAKING ANY OF THE FOLLOWING ACTIONS AGAINST, AS APPLICABLE, THE DEBTORS, THE RELEASED PARTIES, OR THE EXCULPATED PARTIES: (1) COMMENCING OR CONTINUING IN ANY MANNER ANY ACTION OR OTHER PROCEEDING OF ANY KIND ON ACCOUNT OF OR IN CONNECTION WITH OR WITH RESPECT TO ANY OF THE CLAIMS OR INTERESTS RELEASED HEREUNDER; (2) ENFORCING, ATTACHING, COLLECTING, OR RECOVERING BY ANY MANNER OR MEANS ANY JUDGMENT, AWARD, DECREE, OR ORDER AGAINST SUCH ENTITIES ON ACCOUNT OR IN CONNECTION WITH OR WITH RESPECT TO ANY CLAIMS OR INTERESTS RELEASED HEREUNDER; (3) CREATING, PERFECTING, OR ENFORCING ANY LIEN OR ENCUMBRANCE OF ANY KIND AGAINST SUCH ENTITIES OR THE PROPERTY OF SUCH ENTITIES ON ACCOUNT OR IN CONNECTION WITH OR WITH RESPECT TO ANY CLAIMS OR INTERESTS RELEASED HEREUNDER; (4) ASSERTING ANY RIGHT OF SETOFF, SUBROGATION, OR RECOUPMENT OF ANY KIND AGAINST ANY OBLIGATION DUE FROM SUCH ENTITIES OR AGAINST THE PROPERTY OR THE ESTATES OF SUCH ENTITIES ON ACCOUNT OR IN CONNECTION WITH OR WITH RESPECT TO ANY CLAIMS OR INTERESTS RELEASED HEREUNDER, UNLESS SUCH HOLDER HAS FILED A MOTION REQUESTING THE RIGHT TO PERFORM SUCH SETOFF ON OR BEFORE THE EFFECTIVE DATE, AND NOTWITHSTANDING AN INDICATION OF A CLAIM OR INTEREST OR OTHERWISE THAT SUCH HOLDER ASSERTS, HAS, OR INTENDS TO PRESERVE ANY RIGHT OF SETOFF PURSUANT TO APPLICABLE LAW OR OTHERWISE; AND (5) COMMENCING OR CONTINUING IN ANY MANNER ANY ACTION OR OTHER PROCEEDING OF ANY KIND ON ACCOUNT OF OR IN CONNECTION WITH OR WITH RESPECT TO ANY CLAIMS OR INTERESTS RELEASED OR SETTLED PURSUANT TO THIS PLAN.

UPON ENTRY OF THE CONFIRMATION ORDER, ALL HOLDERS OF CLAIMS AND INTERESTS AND THEIR RESPECTIVE CURRENT AND FORMER EMPLOYEES, AGENTS, OFFICERS, DIRECTORS, PRINCIPALS, AND DIRECT AND INDIRECT AFFILIATES SHALL BE ENJOINED FROM TAKING ANY ACTIONS TO INTERFERE WITH THE IMPLEMENTATION OR CONSUMMATION OF THIS PLAN. EXCEPT AS OTHERWISE SET FORTH IN THE CONFIRMATION ORDER, EACH HOLDER OF AN ALLOWED CLAIM OR ALLOWED INTEREST, AS APPLICABLE, BY ACCEPTING, OR BEING ELIGIBLE TO ACCEPT, DISTRIBUTIONS UNDER THIS PLAN SHALL BE DEEMED TO HAVE CONSENTED TO THE INJUNCTION PROVISIONS SET FORTH HEREIN.

Item 3. Certification of Claims in the Voting Class Held in Additional Accounts.

By completing and returning this Ballot, the Beneficial Holder of the Claims identified in Item 1 certifies that this Ballot is the only Ballot submitted for the Claims in the Voting Class identified in Item 1 owned by such Beneficial Holder as indicated in Item 1, except for the Claims identified in the following table. **To be clear, if any Beneficial Holder holds Claims in a Voting**

Class through one or more Nominees, such Beneficial Holder must identify all Claims in the Voting Class held through its own name and/or each Nominee in the following table, and must indicate the same vote to accept or reject the Plan on all Ballots submitted.

ONLY COMPLETE ITEM 3 IF YOU HAVE SUBMITTED OTHER BALLOTS ON ACCOUNT OF THE SAME VOTING CLASS

Account Number of Other Claims Voted in the Voting Class	Name of Owner ⁵	Principal Amount of Other Claims Voted in the Voting Class	CUSIP of Other Claims Voted in the Voting Class	DTC Participant of Claims Voted in the Voting Class
Class 3 – Bond Claims				

Item 4. Certifications.

Upon execution of this Ballot, the undersigned certifies that:

- a. as of the Voting Record Date, the undersigned was the Beneficial Holder (or authorized signatory for a Beneficial Holder with full power and authority to vote to accept or reject the Plan) of the Claims in the Voting Class set forth in Item 1;
- b. the Beneficial Holder has reviewed a copy of the Disclosure Statement, the Plan, the Bondholder Summary, and the remainder of the Solicitation Package and acknowledges that the solicitation is being made pursuant to the terms and conditions set forth therein;
- c. the Beneficial Holder has cast the same vote with respect to all of the Beneficial Holder’s Claims in the Voting Class;
- d. the Beneficial Holder understands and acknowledges that if multiple Ballots are submitted voting the Claim set forth in Item 1, only the last properly completed Ballot or Master Ballot voting the Claim and received by the Solicitation Agent before the Voting Deadline

⁵ Insert your name if the Claims in the respective Voting Class are held by you in your own name or, if held in a street name through a Nominee, insert the name of your broker or bank and their DTC Participant Number.

shall be deemed to reflect the voter's intent and thus to supersede and revoke any prior Ballots received by the Solicitation Agent;

- e. the Beneficial Holder understands and acknowledges that the Solicitation Agent may verify the amount of the Claims in the Voting Class set forth in Item 1 held by the Beneficial Holder as of the Voting Record Date with any Nominee through which the Beneficial Holder holds its the Claims in the Voting Class set forth in Item 1 and by returning an executed Ballot the Beneficial Holder directs any such Nominee to provide any information or comply with any actions requested by the Solicitation Agent to verify the amount set forth in Item 1 hereof. In the event of a discrepancy regarding such amount that cannot be timely reconciled without undue effort on the part of the Solicitation Agent, the amount shown on the records of the Nominee, if applicable, or the Debtors' records shall control; and
- f. the Beneficial Holder understands and acknowledges that all authority conferred or agreed to be conferred pursuant to this Ballot, and every obligation of the Beneficial Holder hereunder, shall be binding upon the transferees, successors, assigns, heirs, executors, administrators, and legal representatives of the Beneficial Holder and shall not be affected by, and shall survive, the death or incapacity of the Beneficial Holder.

Item 5. Beneficial Holder Information and Signature.

Name of Beneficial Holder: _____
(Print or type)

DTC Participant Number: _____

Signature: _____

Name of Signatory: _____
(if other than Beneficial Holder)

Title (and capacity, if other than Beneficial Holder): _____

Address: _____

Date Completed: _____

**THE VOTING DEADLINE IS 4:00 P.M., PREVAILING CENTRAL TIME,
ON MAY 31, 2023.**

**IF YOU RECEIVED A RETURN ENVELOPE ADDRESSED TO THE SOLICITATION
AGENT (DONLIN RECANO & COMPANY, INC.), PLEASE COMPLETE AND DATE
THE BALLOT AND RETURN IT PROMPTLY IN THE ENVELOPE PROVIDED SO
THAT IT IS ACTUALLY RECEIVED BY THE SOLICITATION AGENT BY THE
VOTING DEADLINE.**

**IF YOU RECEIVED A RETURN ENVELOPE ADDRESSED TO YOUR NOMINEE,
PLEASE COMPLETE, SIGN, AND DATE THE BALLOT AND RETURN IT IN THE
ENVELOPE PROVIDED OR OTHERWISE IN ACCORDANCE WITH THE
INSTRUCTIONS PROVIDED BY YOUR NOMINEE. PLEASE ALLOW SUFFICIENT
TIME FOR YOUR BALLOT TO BE INCLUDED ON A MASTER BALLOT
COMPLETED BY YOUR NOMINEE. THE MASTER BALLOT MUST BE ACTUALLY
RECEIVED BY THE SOLICITATION AGENT ON OR BEFORE THE VOTING
DEADLINE.**

**IF YOU HAVE ANY QUESTIONS ABOUT THIS BALLOT OR THE PLAN
SOLICITATION OR YOU NEED ADDITIONAL VOTING MATERIALS, PLEASE
CONTACT THE SOLICITATION AGENT TOLL FREE AT (888) 508-2507 OR VIA
EMAIL AT GWGINFO@DONLINRECANO.COM. IF YOU HAVE QUESTIONS
ABOUT THE VOTING PROCEDURES, PLEASE CONTACT YOUR NOMINEE. ANY
BALLOT RECEIVED AFTER THE VOTING DEADLINE OR OTHERWISE NOT IN**

COMPLIANCE WITH THE DISCLOSURE STATEMENT ORDER WILL NOT BE COUNTED.

VOTING INSTRUCTIONS

1. As described in the Disclosure Statement, the Debtors are soliciting the votes of Beneficial Holders of Class 3 Bond Claims with respect to the Plan referred to in the Disclosure Statement. Links to the Plan and the Disclosure Statement are included in the Solicitation Package you received with the Ballot. Capitalized terms used but not defined herein shall have the meanings assigned to them in the Plan. **PLEASE READ THE PLAN AND THE DISCLOSURE STATEMENT CAREFULLY BEFORE COMPLETING THIS BENEFICIAL HOLDER BALLOT.** You may wish to seek legal advice concerning the Plan and the treatment of your Claim under the Plan.
2. The Plan can be confirmed by the Bankruptcy Court and thereby made binding upon holders of Claims and Interests if it is accepted by the holders of at least two-thirds in amount and more than one-half in number of Claims or at least two thirds in amount of Interests in at least one class that votes on the Plan and if the Plan otherwise satisfies the requirements for confirmation set forth in section 1129(a) of the Bankruptcy Code.
3. To ensure that your vote is counted, you must: (a) complete the Ballot; (b) indicate your decision either to accept or reject the Plan in Item 1 of the Ballot; and (c) **sign and return the Ballot in accordance with the instructions received, so that this Ballot (if “pre-validated” by your Nominee) or a Master Ballot cast on your behalf is actually received by the Solicitation Agent by the Voting Deadline.** If you are returning your Ballot to the Nominee that provided you with this Ballot, your completed Ballot must be sent to your Nominee, allowing sufficient time for your Nominee to receive your Ballot, complete a Master Ballot, and transmit the Master Ballot to the Solicitation Agent so that it is actually received by the Voting Deadline. Your Nominee is authorized to disseminate Solicitation Packages and voting instructions to, and collect voting information from, Beneficial Holders according to its customary practices.

The Solicitation Agent will not accept Beneficial Holder Ballots by facsimile or other electronic means (other than by email at GWGVote@donlinrecano.com for pre-validated Beneficial Holder Ballots and Master Ballots only). If you are directed by your Nominee to submit the Beneficial Holder Ballot to the Nominee via electronic means, such instructions to your Nominee shall have the same effect as if you had completed and returned a physical Beneficial Holder Ballot, including all certifications.
4. The time by which a Ballot or Master Ballot including your vote is **actually received** by the Solicitation Agent shall be the time used to determine whether a Ballot has been submitted by the Voting Deadline. **The Voting Deadline is May 31, 2023, at 4:00 P.M., prevailing Central Time.**
5. If a Ballot is received after the Voting Deadline, it will not be counted except as permitted by applicable law or court order. In all cases, Beneficial Holders should allow sufficient time to assure timely delivery. No Ballot should be sent to the Debtors or the Debtors’ financial or legal advisors. A Ballot will not be counted unless received by the Solicitation Agent.

6. The Beneficial Holder understands and acknowledges that if multiple Ballots are submitted voting the Claim set forth in Item 1, only the last properly completed Ballot or Master Ballot voting the Claim and received by the Solicitation Agent before the Voting Deadline shall be deemed to reflect the voter's intent and thus to supersede and revoke any prior Ballots received by the Solicitation Agent.
7. If a holder holds a Claim or Interest, as applicable, in a Voting Class against multiple Debtors, a vote on their Ballot will apply to all Debtors against whom such holder or Nominee has a Claim or Interest, as applicable, in that Voting Class.
8. If a Beneficial Holder simultaneously casts inconsistent duplicate Ballots, with respect to the same Claim, such Ballots will not be counted.
9. The Ballot is not a letter of transmittal and may not be used for any purpose other than to vote to accept or reject the Plan and to make certain certifications with respect thereto. Accordingly, at this time, creditors should not surrender certificates or instruments representing or evidencing their Claims, and the Debtors will not accept delivery of any such certificates or instruments surrendered together with a Ballot.
10. The Ballot does not constitute, and shall not be deemed to be: (a) a Proof of Claim; or (b) an assertion or admission with respect to any Claim.
11. Please be sure to sign and date your Ballot. If you are completing the Ballot on behalf of an Entity, indicate your relationship with that Entity and the capacity in which you are signing. You may not mark a vote to accept or reject the Plan or complete Item 2 of the Ballot unless expressly authorized in writing by the Beneficial Holder to vote on a chapter 11 plan on such Beneficial Holder's behalf.
12. You must vote your entire Claim in the Voting Class either to accept or reject the Plan and may not split your vote. Accordingly, a Ballot that partially rejects and partially accepts the Plan as to the Voting Class will not be counted as a vote to accept or reject the Plan as to that Class.
13. Any Ballot that is properly completed, executed, and timely returned to the Debtors that fails to indicate acceptance or rejection of the Plan or that indicates both an acceptance and a rejection of the Plan will not be counted.
14. The following Ballots will not be counted in determining the acceptance or rejection of the Plan: (a) any Ballot that is illegible or contains insufficient information to permit the identification of the Beneficial Holder; (b) any Ballot cast by a Person or Entity that does not hold a Claim or Interest in a Class that is entitled to vote on the Plan; (c) any unsigned Ballot; (d) any Ballot not marked to accept or reject the Plan, or marked both to accept and reject the Plan; and/or (e) any Ballot submitted by a party not entitled to cast a vote with respect to the Plan.
15. If you hold Claims or Interests in more than one Class under the Plan or for different Claims within a Class you may receive more than one Ballot. Each Ballot votes only your Claims or Interests indicated on that Ballot. Please complete and return each Ballot you receive.

16. For purposes of the numerosity requirement of section 1126(c) of the Bankruptcy Code, separate Claims or Interests held by a single creditor or interest-holder in a particular Class will be aggregated and treated as if such creditor held one Claim or Interest in such Class, and all votes related to such Claim or Interest will be treated as a single vote to accept or reject the Plan; *provided* that if separate affiliated entities hold Claims or Interests in a particular Class, these Claims or Interests will not be aggregated and will not be treated as if such creditor or interest-holder held one Claim or Interest in such Class, and the vote of each affiliated entity will be counted separately as a vote to accept or reject the Plan.

PLEASE SUBMIT YOUR BALLOT PROMPTLY

IF YOU HAVE ANY QUESTIONS REGARDING THIS BALLOT, THESE VOTING INSTRUCTIONS, OR THE PROCEDURES FOR VOTING, PLEASE CALL THE SOLICITATION AGENT AT:

U.S. TOLL FREE: (888) 508-2507

OR EMAIL GWGINFO@DONLINRECANO.COM

OR CONTACT THE OFFICIAL COMMITTEE OF BONDHOLDERS:

BY EMAIL: GWGBondholders@akingump.com

WEBSITE: <https://www.donlinrecano.com/gwgbondholders>

IF THE SOLICITATION AGENT DOES NOT ACTUALLY RECEIVE THIS BALLOT (IF “PRE-VALIDATED” BY YOUR NOMINEE) ON OR BEFORE THE VOTING DEADLINE, WHICH IS ON MAY 31, 2023 AT 4:00 P.M., PREVAILING CENTRAL TIME, AND IF THE VOTING DEADLINE IS NOT EXTENDED, YOUR VOTE TRANSMITTED HEREBY MAY BE COUNTED ONLY IN THE DISCRETION OF THE DEBTORS.

IF YOU ARE RETURNING YOUR BALLOT TO THE NOMINEE THAT PROVIDED YOU WITH THIS BALLOT, YOUR COMPLETED BALLOT MUST BE SENT TO YOUR NOMINEE, ALLOWING SUFFICIENT TIME FOR YOUR NOMINEE TO RECEIVE YOUR BALLOT, COMPLETE A MASTER BALLOT, AND TRANSMIT THE MASTER BALLOT TO THE SOLICITATION AGENT SO THAT IT IS ACTUALLY RECEIVED BY THE VOTING DEADLINE.

Exhibit 3D

**Form of Ballot
Class 8, 9, and 10 Interests (Direct-Held)**

IN THE UNITED STATES BANKRUPTCY COURT
FOR THE SOUTHERN DISTRICT OF TEXAS
HOUSTON DIVISION

In re:)	Chapter 11
GWG Holdings, Inc., <i>et al.</i> , ¹)	Case No. 22-90032 (MI)
Debtors.)	(Jointly Administered)

CLASS [●]: [●] INTERESTS BALLOT
FOR VOTING TO ACCEPT OR REJECT THE DEBTORS'
SECOND AMENDED JOINT CHAPTER 11 PLAN

PLEASE READ AND FOLLOW THE ENCLOSED INSTRUCTIONS FOR COMPLETING BALLOTS CAREFULLY BEFORE COMPLETING THIS BALLOT.

FOR YOUR VOTE TO BE COUNTED, THIS BALLOT MUST BE COMPLETED, EXECUTED, AND RETURNED SO AS TO BE ACTUALLY RECEIVED BY THE SOLICITATION AGENT BY MAY 31, 2023 AT 4:00 P.M. (PREVAILING CENTRAL TIME) THE (“VOTING DEADLINE”). IF THIS BALLOT IS NOT PROPERLY COMPLETED, EXECUTED, AND RECEIVED BY THE SOLICITATION AGENT ON OR BEFORE THE VOTING DEADLINE, THEN THE VOTES TRANSMITTED BY THIS BALLOT WILL NOT BE COUNTED.

ACCESS TO SOLICITATION MATERIALS:

THE PLAN, DISCLOSURE STATEMENT, AND DISCLOSURE STATEMENT ORDER, INCLUDING THE SOLICITATION PROCEDURES AND THE BONDHOLDER SUMMARY MAY BE ACCESSED FREE OF CHARGE AT [HTTPS://WWW.DONLINRECANO.COM/CLIENTS/GWG/INDEX](https://www.donlinrecano.com/clients/gwg/index) BY CLICKING ON THE “SOLICITATION MATERIALS” LINK ON THE WEBSITE’S LEFT HAND NAVIGATION PANEL.

YOU CAN ALSO OBTAIN COPIES IN PAPER FORMAT OF ANY SOLICITATION MATERIALS (A) FREE OF CHARGE BY (I) ACCESSING THE DEBTORS’ RESTRUCTURING WEBSITE AT [HTTPS://WWW.DONLINRECANO.COM/CLIENTS/GWG/INDEX](https://www.donlinrecano.com/clients/gwg/index); (II) WRITING

¹ The Debtors in these chapter 11 cases, along with the last four digits of each Debtor’s federal tax identification number, are: GWG Holdings, Inc. (2607); GWG Life, LLC (6955); GWG Life USA, LLC (5538) GWG DLP Funding IV, LLC (2598); GWG DLP Funding VI, LLC (6955) and GWG DLP Funding Holdings VI, LLC (6955). The location of Debtor GWG Holdings, Inc.’s principal place of business and the Debtors’ service address is 325 N. St. Paul Street, Suite 2650, Dallas, TX 75201. Further information regarding the Debtors and these chapter 11 cases is available at the website of the Debtors’ claims and noticing agent: <https://donlinrecano.com/gwg>.

**TO DONLIN, RECANO & COMPANY, INC., RE: GWG HOLDINGS, INC., ET AL.,
P.O. BOX 199043, BLYTHEBOURNE STATION, BROOKLYN, NY 11219; (III)
CALLING 1 (888) 508-2507 (U.S. TOLL FREE); OR (IV) EMAILING
GWGINFO@DONLINRECANO.COM; OR (B) FOR A FEE VIA PACER AT
[HTTPS://ECF.TXSB.USCOURTS.GOV/](https://ecf.txsb.uscourts.gov/).**

Solicitation Overview

The above-captioned debtors and debtors in possession (collectively, the “Debtors”), are soliciting votes with respect to the Plan as set forth in the *Disclosure Statement for the Debtors’ Second Amended Joint Chapter 11 Plan* [Docket No. 1682] (as may be amended, supplemented, or modified, the “Disclosure Statement”) and the *Debtors’ Second Amended Joint Chapter 11 Plan* [Docket No. 1678] (as may be amended, supplemented, or modified, the “Plan”).² The Bankruptcy Court for the Southern District of Texas (the “Court”) has approved the Disclosure Statement as containing adequate information pursuant to section 1125 of the Bankruptcy Code, by entry of an order on April 21, 2023 [Docket No. 1681³] (the “Disclosure Statement Order”). Court approval of the Disclosure Statement does not indicate approval of the Plan by the Court.

Your rights are described in the Plan, the Disclosure Statement, and the related materials. If you would like paper copies of the Plan, Disclosure Statement, and other Solicitation Materials, or if you need to obtain additional Solicitation Packages, you may obtain them (a) at no charge from Donlin Recano & Company, Inc. (the “Solicitation Agent”) by: (i) accessing the Debtors’ restructuring website at <https://www.donlinrecano.com/Clients/gwg/Index>; (ii) calling 1 (888) 508-2507 (U.S. toll-free) or (iii) emailing gwginfo@donlinrecano.com; or (b) for a fee via PACER at <https://ecf.txsb.uscourts.gov/>.

You are receiving this ballot (the “Ballot”) because records indicate that you are the direct Holder of a Class [●] [●] as of the Voting Record Date (as defined in the Disclosure Statement Order), or an assignee or transferee thereof. Accordingly, you have a right to vote to accept or reject the Plan. As set forth in the Disclosure Statement, the Debtors, the Bondholder Committee, LBM, and the Ad Hoc Committee of Broker/Dealers recommend that you vote to **ACCEPT** the Plan.

If the Plan is confirmed by the Court, it will be binding on you regardless of whether or not you vote or whether you vote to accept or reject the Plan. To have your vote counted, you must complete, sign, and return this Ballot so that it is received by the Solicitation Agent no later than the Voting Deadline.

This Ballot may not be used for any purpose other than for casting votes to accept or reject the Plan and making certain certifications with respect to the Plan. If you believe you have received this Ballot in error, or if you believe you have received the wrong ballot, please contact the Solicitation Agent immediately at the address, telephone number, or email address set forth above.

² Capitalized terms used but not otherwise defined herein shall have the meanings ascribed to such terms in the Plan, the Disclosure Statement, or the Disclosure Statement Order, as applicable.

³ As modified pursuant to the order entered at docket 1692.

ARTICLE VIII OF THE PLAN CONTAINS RELEASE, EXCULPATION, AND INJUNCTION PROVISIONS.

Submitting Your Ballot

You should review the Plan and the Disclosure Statement and the instructions contained herein before you vote. You may wish to seek legal advice concerning the Plan and the Plan's classification and treatment of your Interest. **THE DEBTORS AND THE SOLICITATION AGENT ARE NOT AUTHORIZED TO PROVIDE, AND WILL NOT PROVIDE, LEGAL ADVICE.**

PLEASE SUBMIT YOUR BALLOT BY *ONLY ONE* OF THE FOLLOWING METHODS:

Via Electronic Mail. Complete, sign, and date this Ballot and email a scanned copy of the ballot in a universally viewable file format such as .PDF to GWGVote@donlinrecano.com.

OR

Via Paper Ballot. Complete, sign, and date this Ballot and return it (with an original signature) promptly in the envelope provided or:

By First Class Mail to:

**GWG HOLDINGS, INC., ET AL. Balloting Center
c/o Donlin Recano Company
Attn: Voting Department
P.O. Box 199043 Blythebourne Station
Brooklyn, NY 11219**

By Hand Delivery or Overnight Mail to:

**GWG HOLDINGS, INC., ET AL. Balloting Center
c/o Donlin Recano Company
Attn: Voting Department
6201 15th Ave
Brooklyn, NY 11219**

OR

Via eBallot Portal:

Ballots may be submitted via an electronic Ballot through the Voting Agent's on-line electronic Ballot submission portal at www.DonlinRecano.com/clients/gwg/vote (the "eBallot Portal") by no later than the Voting Deadline. Any failure to follow the voting instructions included with the Ballot may disqualify your Ballot and your vote.

In order to submit a Ballot through the eBallot Portal, you must use the Unique eBallot ID# assigned to your Interest. Please complete and submit an electronic Ballot for each eBallot ID# you receive.

UNIQUE E-BALLOT IDENTIFICATION _____

Each eBallot ID# is to be used solely for voting only those Interests described in Item 1 of your electronic Ballot. Please complete and submit an electronic Ballot for each eBallot ID# you receive, as applicable.

Creditors who cast a Ballot using the E-Ballot Portal should NOT also submit a paper Ballot.

Item 1. Amount of Interest.⁴

The undersigned hereby certifies that as of the Voting Record Date, the undersigned was the Holder of [●] shares of Class [●] [●] (insert amount in box below):

Any admission of Interest for purposes of voting on the Plan is not an admission of liability on the part of the Debtors or any other party for payment purposes. Additionally, **The above amount may not be the same as the amount you included in a filed Proof of Interest, and the above amount excludes accrued interest solely for voting tabulation purposes.**

Item 2. Vote on Plan.

The Holder of Class [●] [●] set forth in Item 1 votes to (please check only one):

<input type="checkbox"/> <u>ACCEPT</u> (vote FOR) the Plan	<input type="checkbox"/> <u>REJECT</u> (vote AGAINST) the Plan
---	---

Item 3. Important information regarding the release, exculpation, and injunction provisions in the Plan.⁵

Article VIII.C of the Plan contains the following release (the "**Release**"):

PURSUANT TO SECTION 1123(B) OF THE BANKRUPTCY CODE, IN EXCHANGE FOR GOOD AND VALUABLE CONSIDERATION, THE ADEQUACY OF WHICH IS HEREBY CONFIRMED, ON AND AFTER THE EFFECTIVE DATE, EACH RELEASED

⁴ For voting purposes only, subject to tabulation rules.

⁵ The Plan provisions referenced herein are for summary purposes only and do not include all provisions of the Plan that may affect your rights. If there is any inconsistency between the provisions set forth herein and the Plan, the Plan governs. You should read the Plan before completing this Ballot.

PARTY (BUT NO NON-RELEASED PARTY) IS, AND IS DEEMED HEREBY TO BE, FULLY, CONCLUSIVELY, ABSOLUTELY, UNCONDITIONALLY, IRREVOCABLY, AND FOREVER RELEASED AND DISCHARGED BY THE DEBTORS, THE WIND DOWN DEBTORS, AND THEIR ESTATES, AND ANY PERSON SEEKING TO EXERCISE THE RIGHTS OF THE DEBTORS OR THEIR ESTATES, INCLUDING ANY SUCCESSORS TO THE DEBTORS OR ANY ESTATES REPRESENTATIVES APPOINTED OR SELECTED PURSUANT TO SECTION 1123(B)(3) OF THE BANKRUPTCY CODE, IN EACH CASE ON BEHALF OF THEMSELVES AND THEIR RESPECTIVE SUCCESSORS, ASSIGNS, AND REPRESENTATIVES, AND ANY AND ALL OTHER ENTITIES WHO MAY PURPORT TO ASSERT ANY CAUSE OF ACTION, DIRECTLY OR DERIVATIVELY, BY, THROUGH OR FOR THE DEBTORS OR THEIR ESTATES, FROM ANY AND ALL CLAIMS AND CAUSES OF ACTION, WHETHER KNOWN OR UNKNOWN, INCLUDING ANY DERIVATIVE CLAIMS, ASSERTED OR ASSERTABLE ON BEHALF OF THE DEBTORS, WHETHER KNOWN OR UNKNOWN, FORESEEN OR UNFORESEEN, MATURED OR UNMATURED, EXISTING OR HEREAFTER ARISING, CONTINGENT OR NON-CONTINGENT, IN LAW, EQUITY, CONTRACT, TORT OR OTHERWISE, EXCEPT FOR ANY CLAIMS RELATED TO ANY ACT OR OMISSION THAT IS DETERMINED IN A FINAL ORDER TO HAVE CONSTITUTED ACTUAL FRAUD, WILLFUL MISCONDUCT, INTENTIONAL BREACH OF FIDUCIARY DUTY, OR GROSS NEGLIGENCE, THAT THE DEBTORS, THE WIND DOWN DEBTORS, OR THEIR ESTATES, INCLUDING ANY SUCCESSORS TO THE DEBTORS OR ANY ESTATES REPRESENTATIVE APPOINTED OR SELECTED PURSUANT TO SECTION 1123(B) OF THE BANKRUPTCY CODE, WOULD HAVE BEEN LEGALLY ENTITLED TO ASSERT IN THEIR OWN RIGHT (WHETHER INDIVIDUALLY OR COLLECTIVELY) OR ON BEHALF OF THE HOLDER OF ANY CLAIM OR INTEREST IN, A DEBTOR OR OTHER ENTITY, OR THAT ANY HOLDER OF ANY CLAIM AGAINST, OR INTEREST IN, A DEBTOR OR OTHER ENTITY COULD HAVE ASSERTED ON BEHALF OF THE DEBTORS, BASED ON OR RELATING TO, OR IN ANY MANNER ARISING FROM, IN WHOLE OR IN PART, THE DEBTORS (INCLUDING THE CAPITAL STRUCTURE, MANAGEMENT, OWNERSHIP OR OPERATION THEREOF), THE BUSINESS OR CONTRACTUAL ARRANGEMENT BETWEEN THE DEBTORS AND ANY RELEASED PARTY, ANY SECURITIES ISSUED BY THE DEBTORS AND THE OWNERSHIP THEREOF, THE ASSERTION OR ENFORCEMENT OF RIGHTS AND REMEDIES AGAINST THE DEBTORS, THE DEBTORS' IN- OR OUT-OF-COURT RESTRUCTURING EFFORTS, ANY AVOIDANCE ACTIONS (BUT EXCLUDING AVOIDANCE ACTIONS BROUGHT AS COUNTERCLAIMS OR DEFENSES TO CLAIMS ASSERTED AGAINST THE DEBTORS), INTERCOMPANY TRANSACTIONS BETWEEN OR AMONG A DEBTOR AND ANOTHER DEBTOR, THE FORMULATION, PREPARATION, DISSEMINATION, NEGOTIATION, OR FILING OF THE DISCLOSURE STATEMENT, THE PLAN (INCLUDING, FOR THE AVOIDANCE OF DOUBT, THE PLAN SUPPLEMENT), THE VIDA DIP FINANCING FACILITY, THE VIDA EXIT FINANCING FACILITY, OR ANY WIND DOWN TRANSACTION, CONTRACT, INSTRUMENT, RELEASE, OR OTHER AGREEMENT OR DOCUMENT (INCLUDING ANY LEGAL OPINION REQUESTED BY ANY ENTITY REGARDING ANY TRANSACTION, CONTRACT, INSTRUMENT, DOCUMENT OR OTHER AGREEMENT CONTEMPLATED BY THE PLAN OR THE

RELIANCE BY ANY RELEASED PARTY ON THE PLAN OR THE CONFIRMATION ORDER IN LIEU OF SUCH LEGAL OPINION) CREATED OR ENTERED INTO IN CONNECTION WITH THE DISCLOSURE STATEMENT, THE VIDA EXIT FINANCING FACILITY DOCUMENTS, THE PLAN, OR THE PLAN SUPPLEMENT, BEFORE OR DURING THE CHAPTER 11 CASES, THE CHAPTER 11 CASES, THE FILING OF THE CHAPTER 11 CASES, THE PURSUIT OF CONFIRMATION, THE ADMINISTRATION AND IMPLEMENTATION OF THE PLAN, INCLUDING THE ISSUANCE OR DISTRIBUTION OF SECURITIES PURSUANT TO THE PLAN, OR THE DISTRIBUTION OF PROPERTY UNDER THE PLAN, OR UPON ANY RELATED ACT OR OMISSION, TRANSACTION, AGREEMENT, EVENT, OR OTHER OCCURRENCE RELATED OR RELATING TO ANY OF THE FOREGOING TAKING PLACE ON OR BEFORE THE EFFECTIVE DATE RELATED OR RELATING TO THE FOREGOING INCLUDING ALL RELIEF OBTAINED BY THE DEBTORS IN THE CHAPTER 11 CASES. FOR THE AVOIDANCE OF DOUBT, THE LBM RELEASED PARTIES, TO THE EXTENT THAT LBM HAS NOT WITHDRAWN FROM THE SETTLEMENT DESCRIBED IN ARTICLE IV.I OF THIS PLAN, SHALL CONSTITUTE RELEASED PARTIES WITH RESPECT TO THIS DEBTOR RELEASE.

NOTWITHSTANDING ANYTHING TO THE CONTRARY IN THE FOREGOING, THE RELEASES SET FORTH ABOVE DO NOT RELEASE: (1) POST-EFFECTIVE DATE OBLIGATIONS OF ANY PARTY OR ENTITY UNDER THE PLAN, THE CONFIRMATION ORDER, ANY WIND DOWN TRANSACTION, OR ANY OTHER DOCUMENT, INSTRUMENT, OR AGREEMENT (INCLUDING THOSE SET FORTH IN THE PLAN SUPPLEMENT) EXECUTED TO IMPLEMENT THE PLAN, INCLUDING THE VIDA EXIT FINANCING FACILITY DOCUMENTS, OR ANY CLAIM OR OBLIGATION ARISING UNDER THE PLAN; (2) THE RIGHTS OF ANY HOLDER OF ALLOWED CLAIMS TO RECEIVE DISTRIBUTIONS UNDER THE PLAN; (3) THE RETAINED CAUSES OF ACTION; (4) ANY CLAIMS RELATED TO ANY ACT OR OMISSION THAT IS DETERMINED IN A FINAL ORDER TO HAVE CONSTITUTED ACTUAL FRAUD, WILLFUL MISCONDUCT, INTENTIONAL BREACH OF FIDUCIARY DUTY, OR GROSS NEGLIGENCE; (5) THE DEBTORS' PREPETITION LEGAL COUNSEL SOLELY WITH RESPECT TO CLAIMS OR CAUSES OF ACTION ARISING FROM SUCH COUNSEL'S PREPETITION ADVICE TO THE DEBTORS AND/OR ANY FORMER DIRECTORS OR OFFICERS OF THE DEBTORS OTHER THAN ADVICE DIRECTLY RELATING TO THE PREPARATION AND FILING OF THE CHAPTER 11 CASES (IT BEING UNDERSTOOD ANY PREPETITION ADVICE TO THE DEBTORS RELATING TO PREPETITION TRANSACTIONS BETWEEN THE DEBTORS AND BENEFICIENT SHALL NOT CONSTITUTE ADVICE DIRECTLY RELATING TO THE PREPARATION AND FILING OF THE CHAPTER 11 CASES); OR (6) ANY NON-RELEASED PARTY.

ENTRY OF THE CONFIRMATION ORDER SHALL CONSTITUTE THE BANKRUPTCY COURT'S APPROVAL, PURSUANT TO BANKRUPTCY RULE 9019, OF THE FOREGOING DEBTOR RELEASE, WHICH INCLUDES BY REFERENCE EACH OF THE RELATED PROVISIONS AND DEFINITIONS CONTAINED IN THE PLAN, AND FURTHER, SHALL CONSTITUTE THE BANKRUPTCY COURT'S FINDING THAT THE DEBTOR RELEASE IS: (A) IN EXCHANGE FOR THE GOOD

AND VALUABLE CONSIDERATION PROVIDED BY THE RELEASED PARTIES, INCLUDING, WITHOUT LIMITATION, THE RELEASED PARTIES' CONTRIBUTIONS TO FACILITATING THE WIND DOWN TRANSACTIONS AND IMPLEMENTING THE PLAN; (B) A GOOD FAITH SETTLEMENT AND COMPROMISE OF THE CLAIMS RELEASED BY THE DEBTOR RELEASE; (C) IN THE BEST INTERESTS OF THE DEBTORS AND ALL HOLDERS OF CLAIMS AND INTERESTS; (D) FAIR, EQUITABLE, AND REASONABLE; (E) GIVEN AND MADE AFTER DUE NOTICE AND OPPORTUNITY FOR HEARING; AND (F) A BAR TO ANY OF THE DEBTORS, THE WIND DOWN DEBTORS, OR THE DEBTORS' ESTATES ASSERTING ANY CLAIM OR CAUSE OF ACTION RELEASED PURSUANT TO THE DEBTOR RELEASE.

“RELEASED PARTY” MEANS, COLLECTIVELY, AND IN EACH CASE IN THEIR RESPECTIVE CAPACITIES AS SUCH AND SUBJECT TO THE LIMITATIONS SET FORTH IN ARTICLE VIII.C HEREOF: (A) (I) THE DEBTORS AND THE WIND DOWN DEBTORS, (II) VIDA, (III) THE BONDHOLDER COMMITTEE AND EACH OF ITS MEMBERS, (IV) ANTHONY R. HORTON, IN HIS CAPACITIES AS AN INDEPENDENT DIRECTOR AND DIRECTOR OF THE DEBTORS, (V) JEFFREY S. STEIN, IN HIS CAPACITIES AS AN OFFICER, AN INDEPENDENT DIRECTOR, AND A DIRECTOR OF THE DEBTORS, (VI) MICHAEL A. TUCKER, IN HIS CAPACITY AS AN OFFICER OF THE DEBTORS, (VII) THE DLP INDEPENDENT DIRECTORS, (VIII) FTI CONSULTING, INC., (IX) PJT PARTNERS LP, AND (X) ANY OTHER PROFESSIONAL RETAINED BY THE DEBTORS, THE INDEPENDENT DIRECTORS, THE DLP INDEPENDENT DIRECTORS, OR THE BONDHOLDER COMMITTEE BY ORDER OF THE BANKRUPTCY COURT IN THE CHAPTER 11 CASES OR ANY PROFESSIONAL RETAINED BY ANY OF THE MEMBERS OF THE BONDHOLDER COMMITTEE, EACH IN SUCH CAPACITY; AND (B) SOLELY TO THE EXTENT AND ON THE TERMS AND CONDITIONS SET FORTH IN THIS PLAN, THE LBM RELEASED PARTIES.

“NON-RELEASED PARTIES” SHALL MEAN ANY ENTITIES THAT ARE NOT RELEASED PARTIES, WHICH ENTITIES SHALL INCLUDE, WITHOUT LIMITATION, BENEFICIENT, ITS CURRENT AND FORMER DIRECTORS AND OFFICERS (INCLUDING, WITHOUT LIMITATION, BRADLEY K. HEPPNER, THOMAS O. HICKS, BRUCE W. SCHNITZER, DENNIS P. LOCKHART, AND PETER T. CANGANY), HCLP NOMINEES, L.L.C., THE DEBTORS' FORMER DIRECTORS AND OFFICERS (INCLUDING, WITHOUT LIMITATION, MURRAY HOLLAND AND TIMOTHY EVANS) IN THEIR CAPACITY OR CAPACITIES AS SUCH, AND ANY ENTITIES AFFILIATED WITH OR OTHERWISE RELATED TO THE FOREGOING.

Article VIII.E of the Plan provides for an exculpation of certain parties (the “Exculpation”):

EXCEPT AS OTHERWISE EXPRESSLY STATED IN THIS PLAN OR THE CONFIRMATION ORDER, AS OF THE EFFECTIVE DATE, EACH EXCULPATED PARTY SHALL BE DEEMED TO BE RELEASED AND EXCULPATED FROM ANY CLAIM, OBLIGATION, CAUSE OF ACTION, OR LIABILITY FOR ANY EXCULPATED CLAIM, EXCEPT FOR CLAIMS RELATED TO ANY ACT OR

OMISSION THAT IS DETERMINED IN A FINAL ORDER TO HAVE CONSTITUTED INTENTIONAL BREACH OF FIDUCIARY DUTY, ACTUAL FRAUD, WILLFUL MISCONDUCT, OR GROSS NEGLIGENCE, BUT IN ALL RESPECTS EACH DEBTOR AND EACH EXCULPATED PARTY SHALL BE ENTITLED TO REASONABLY RELY UPON THE ADVICE OF COUNSEL WITH RESPECT TO THEIR DUTIES AND RESPONSIBILITIES PURSUANT TO THE PLAN. THE EXCULPATED PARTIES HAVE, AND UPON THE CONSUMMATION OF THE PLAN, SHALL BE DEEMED TO HAVE, PARTICIPATED IN GOOD FAITH AND IN COMPLIANCE WITH APPLICABLE LAW WITH REGARD TO THE RESTRUCTURING OF CLAIMS AND INTERESTS IN THE CHAPTER 11 CASES AND IN CONNECTION WITH THE WIND DOWN TRANSACTIONS, THE NEGOTIATION, FORMULATION, OR PREPARATION OF THE WIND DOWN DOCUMENTS OR RELATED AGREEMENTS, INSTRUMENTS, OR OTHER DOCUMENTS (INCLUDING, FOR THE AVOIDANCE OF DOUBT, PROVIDING ANY LEGAL OPINION REQUESTED BY ANY ENTITY REGARDING ANY TRANSACTION, CONTRACT, INSTRUMENT, DOCUMENT, OR OTHER AGREEMENT CONTEMPLATED BY THE PLAN OR THE RELIANCE BY ANY RELEASED PARTY ON THE PLAN OR THE CONFIRMATION ORDER IN LIEU OF SUCH LEGAL OPINION) IN CONNECTION WITH THE PLAN, AND THE SOLICITATION OF THE PLAN AND DISTRIBUTIONS PURSUANT TO THE PLAN AND, THEREFORE, ARE NOT, AND ON ACCOUNT OF SUCH DISTRIBUTIONS SHALL NOT BE, LIABLE AT ANY TIME FOR THE VIOLATION OF ANY APPLICABLE LAW, RULE, OR REGULATION GOVERNING THE SOLICITATION OF ACCEPTANCES OR REJECTIONS OF THE PLAN OR SUCH DISTRIBUTIONS MADE PURSUANT TO THE PLAN, EXCEPT FOR CLAIMS RELATED TO ANY ACT OR OMISSION THAT IS DETERMINED IN A FINAL ORDER TO HAVE CONSTITUTED INTENTIONAL BREACH OF FIDUCIARY DUTY, ACTUAL FRAUD, WILLFUL MISCONDUCT, OR GROSS NEGLIGENCE. THE DEBTORS AND THE CREDITOR PROPONENTS AGREE THAT (1) NEITHER THE ACT ITSELF OF FILING OR PROSECUTING A MOTION TO APPROVE A SETTLEMENT OF ANY ESTATE CAUSES OF ACTION WITH BENEFICIENT, ANY OF ITS AFFILIATES OR RELATED PARTIES, AND/OR ANY OTHER NON-RELEASED PARTY NOR THE ACT ITSELF OF FILING OR PROSECUTING ANY OBJECTION TO ANY SUCH SETTLEMENT IN AND OF ITSELF CONSTITUTES AN INTENTIONAL BREACH OF FIDUCIARY DUTY, AND (2) ANY CLAIMS THAT THE DEBTORS OR THE CREDITOR PROPONENTS MAY SEEK TO BRING AGAINST ANY EXCULPATED PARTY SHALL BE LIMITED TO ANY ACTIONS OF SUCH EXCULPATED PARTY SOLELY AFTER THE DATE OF EXECUTION OF THE MEDIATION AGREEMENT; PROVIDED THAT ANY SUCH CLAIMS MUST BE FILED EXCLUSIVELY IN THE BANKRUPTCY COURT AND IN ACCORDANCE WITH THE FEDERAL RULES OF CIVIL PROCEDURES, AND SUCH CLAIMS SHALL BE PLED WITH SPECIFICITY WITH RESPECT TO THE WHO, WHAT, WHEN, WHERE, AND HOW OF THE ALLEGED WRONGFUL CONDUCT.

“EXCULPATED PARTY” MEANS, COLLECTIVELY, AND IN EACH CASE, IN THEIR RESPECTIVE CAPACITIES AS SUCH: (A) JEFFREY S. STEIN, IN HIS CAPACITIES AS AN OFFICER, AN INDEPENDENT DIRECTOR, AND A DIRECTOR OF THE DEBTORS; (B) ANTHONY R. HORTON, IN HIS CAPACITIES AS AN INDEPENDENT

DIRECTOR AND DIRECTOR OF THE DEBTORS; (C) MICHAEL A. TUCKER, IN HIS CAPACITY AS AN OFFICER OF THE DEBTORS; (D) THE NON-MANAGEMENT DIRECTORS, IN THEIR CAPACITY AS SUCH; (E) THE DLP INDEPENDENT DIRECTORS, IN THEIR CAPACITY AS SUCH; (F) THE MEMBERS OF THE BONDHOLDER COMMITTEE, IN THEIR CAPACITY AS SUCH; (G) ANY PROFESSIONAL RETAINED BY THE DEBTORS, THE INDEPENDENT DIRECTORS, THE DLP INDEPENDENT DIRECTORS, THE BONDHOLDER COMMITTEE, IN SUCH PROFESSIONALS' CAPACITY AS SUCH; AND (H) ANY PROFESSIONAL RETAINED BY ANY OF THE MEMBERS OF THE BONDHOLDER COMMITTEE, EACH IN SUCH PROFESSIONALS' CAPACITY AS SUCH.

“EXCULPATED CLAIM” MEANS ANY CLAIM RELATED TO ANY ACT OR OMISSION FROM THE PETITION DATE TO THE EFFECTIVE DATE IN CONNECTION WITH, RELATING TO, OR ARISING OUT OF: (A) THE CHAPTER 11 CASES; (B) THE FORMULATION, PREPARATION, DISSEMINATION, OR NEGOTIATION OF ANY DOCUMENT IN CONNECTION WITH THE CHAPTER 11 CASES; (C) ANY CONTRACT, INSTRUMENT, RELEASE, AND/OR OTHER AGREEMENT OR DOCUMENT CREATED OR ENTERED INTO IN CONNECTION WITH THE CHAPTER 11 CASES; (D) THE PURSUIT OF CONSUMMATION; AND/OR (E) THE FILING, ADMINISTRATION, AND/OR IMPLEMENTATION OF THE CHAPTER 11 CASES, OR THE DISTRIBUTION OF PROPERTY IN CONNECTION THEREWITH OR THEREUNDER; PROVIDED, THAT, FOR THE AVOIDANCE OF DOUBT, ANY PREPETITION ADVICE PROVIDED BY ANY LEGAL PROFESSIONALS IN CONNECTION WITH PREPETITION TRANSACTIONS BETWEEN THE DEBTORS AND BENEFICIENT SHALL NOT CONSTITUTE ANY ACT OR OMISSION THAT IS COVERED BY THIS DEFINITION OF EXCULPATED CLAIM; PROVIDED, FURTHER, THAT, NOTWITHSTANDING THE FOREGOING, EXCULPATED CLAIMS SHALL NOT INCLUDE ANYTHING RELATED TO ANY ACT OR OMISSION THAT IS DETERMINED IN A FINAL ORDER TO HAVE CONSTITUTED ACTUAL FRAUD, WILLFUL MISCONDUCT, INTENTIONAL BREACH OF FIDUCIARY DUTY, OR GROSS NEGLIGENCE.

Article VIII.G of the Plan establishes an injunction (the “Injunction”):

EXCEPT AS OTHERWISE EXPRESSLY PROVIDED IN THE PLAN OR THE CONFIRMATION ORDER OR FOR OBLIGATIONS OR DISTRIBUTIONS REQUIRED TO BE PAID PURSUANT TO THE PLAN OR THE CONFIRMATION ORDER, ALL ENTITIES WHO HAVE HELD, HOLD, OR MAY HOLD CLAIMS THAT HAVE BEEN RELEASED PURSUANT TO ARTICLE VIII HEREOF ARE PERMANENTLY ENJOINED, FROM AND AFTER THE EFFECTIVE DATE, FROM TAKING ANY OF THE FOLLOWING ACTIONS AGAINST, AS APPLICABLE, THE DEBTORS, THE RELEASED PARTIES, OR THE EXCULPATED PARTIES: (1) COMMENCING OR CONTINUING IN ANY MANNER ANY ACTION OR OTHER PROCEEDING OF ANY KIND ON ACCOUNT OF OR IN CONNECTION WITH OR WITH RESPECT TO ANY OF THE CLAIMS OR INTERESTS RELEASED HEREUNDER; (2) ENFORCING, ATTACHING, COLLECTING, OR RECOVERING BY ANY MANNER OR MEANS ANY JUDGMENT, AWARD, DECREE, OR ORDER AGAINST SUCH ENTITIES ON

ACCOUNT OR IN CONNECTION WITH OR WITH RESPECT TO ANY CLAIMS OR INTERESTS RELEASED HEREUNDER; (3) CREATING, PERFECTING, OR ENFORCING ANY LIEN OR ENCUMBRANCE OF ANY KIND AGAINST SUCH ENTITIES OR THE PROPERTY OF SUCH ENTITIES ON ACCOUNT OR IN CONNECTION WITH OR WITH RESPECT TO ANY CLAIMS OR INTERESTS RELEASED HEREUNDER; (4) ASSERTING ANY RIGHT OF SETOFF, SUBROGATION, OR RECOUPMENT OF ANY KIND AGAINST ANY OBLIGATION DUE FROM SUCH ENTITIES OR AGAINST THE PROPERTY OR THE ESTATES OF SUCH ENTITIES ON ACCOUNT OR IN CONNECTION WITH OR WITH RESPECT TO ANY CLAIMS OR INTERESTS RELEASED HEREUNDER, UNLESS SUCH HOLDER HAS FILED A MOTION REQUESTING THE RIGHT TO PERFORM SUCH SETOFF ON OR BEFORE THE EFFECTIVE DATE, AND NOTWITHSTANDING AN INDICATION OF A CLAIM OR INTEREST OR OTHERWISE THAT SUCH HOLDER ASSERTS, HAS, OR INTENDS TO PRESERVE ANY RIGHT OF SETOFF PURSUANT TO APPLICABLE LAW OR OTHERWISE; AND (5) COMMENCING OR CONTINUING IN ANY MANNER ANY ACTION OR OTHER PROCEEDING OF ANY KIND ON ACCOUNT OF OR IN CONNECTION WITH OR WITH RESPECT TO ANY CLAIMS OR INTERESTS RELEASED OR SETTLED PURSUANT TO THIS PLAN.

UPON ENTRY OF THE CONFIRMATION ORDER, ALL HOLDERS OF CLAIMS AND INTERESTS AND THEIR RESPECTIVE CURRENT AND FORMER EMPLOYEES, AGENTS, OFFICERS, DIRECTORS, PRINCIPALS, AND DIRECT AND INDIRECT AFFILIATES SHALL BE ENJOINED FROM TAKING ANY ACTIONS TO INTERFERE WITH THE IMPLEMENTATION OR CONSUMMATION OF THIS PLAN. EXCEPT AS OTHERWISE SET FORTH IN THE CONFIRMATION ORDER, EACH HOLDER OF AN ALLOWED CLAIM OR ALLOWED INTEREST, AS APPLICABLE, BY ACCEPTING, OR BEING ELIGIBLE TO ACCEPT, DISTRIBUTIONS UNDER THIS PLAN SHALL BE DEEMED TO HAVE CONSENTED TO THE INJUNCTION PROVISIONS SET FORTH HEREIN.

Item 4. Certifications.

By signing this Ballot, the undersigned certifies to the Court and the Debtors that:

- (a) as of the Voting Record Date, either: (i) the Entity is the Holder of the Interests being voted; or (ii) the Entity is an authorized signatory for an Entity that is a Holder of the Interests being voted;
- (b) the Entity (or in the case of an authorized signatory, the Holder) has received the Solicitation Package and acknowledges that the solicitation is being made pursuant to the terms and conditions set forth therein;
- (d) the Entity has cast the same vote with respect to all of its Interests in the above-referenced Class; and

- (e) no other Ballots with respect to the amount of the Interests identified in Item 1 have been cast or, if any other Ballots have been cast with respect to such Interests, then any such earlier Ballots are hereby revoked.

Name of Holder: _____ (Print or Type)
Signature: _____
Name of Signatory: _____ (If other than Holder)
Title: _____
Address: _____ _____ _____
Telephone Number: _____
Email: _____
Date Completed: _____

IF THE SOLICITATION AGENT DOES NOT ACTUALLY RECEIVE THIS BALLOT ON OR BEFORE MAY 31, 2023 AT 4:00 P.M. PREVAILING CENTRAL TIME, AND IF THE VOTING DEADLINE IS NOT EXTENDED, YOUR VOTE TRANSMITTED BY THIS BALLOT MAY BE COUNTED TOWARD CONFIRMATION OF THE PLAN ONLY IN THE DISCRETION OF THE DEBTORS.

INSTRUCTIONS FOR COMPLETING THIS BALLOT

1. The Debtors are soliciting the votes of Holders of Claims and Interests with respect to the Plan. **PLEASE READ THE PLAN AND THE DISCLOSURE STATEMENT CAREFULLY BEFORE COMPLETING THIS BALLOT.**
2. The Plan can be confirmed by the Court and thereby made binding upon you if it is accepted by the Holders of at least two-thirds in total dollar amount and more than one-half in number of Claims that actually vote on the Plan and if the Plan otherwise satisfies the requirements for confirmation provided by section 1129(a) of the Bankruptcy Code. Please review the Disclosure Statement for more information.
3. To ensure that your Ballot is counted, you **must** complete and submit this Ballot as instructed herein. **Ballots will not be accepted by facsimile.**
4. **Use of Ballot.** To ensure that your Ballot is counted, you must: (a) complete your Ballot in accordance with these instructions; (b) clearly indicate your decision either to accept or reject the Plan in the boxes provided in Item 2 of the Ballot; and (c) clearly sign and submit your Ballot as instructed herein.
5. Your completed Ballot **must** be returned to the **Solicitation Agent** so as to be **actually received** by the Solicitation Agent on or before the Voting Deadline. **Do not** send Ballots to the Debtors, Indenture Trustee, Bondholder Committee, any advisors to the foregoing, the Court. **The Voting Deadline is May 31, 2023 at 4:00 p.m. (prevailing Central Time).**
6. If a Ballot is received after the Voting Deadline and if the Voting Deadline is not extended, it may not be counted. Additionally, the following Ballots will not be counted:
 - (a) any Ballot that partially rejects and partially accepts the Plan;
 - (b) Ballots delivered to any party other than the Solicitation Agent;
 - (c) Ballots sent by facsimile or other unapproved means;
 - (d) any Ballot that is illegible or contains insufficient information to permit the identification of the Holder of the Interest;
 - (e) any Ballot cast by an Entity that does not hold an Interest entitled to vote pursuant to the Plan or Solicitation Procedures;
 - (f) any Ballot submitted by a Holder not entitled to vote pursuant to the Plan or Solicitation Procedures;
 - (g) any unsigned Ballot (for the avoidance of doubt, Ballots validly submitted through the E-Ballot Portal or via email will be deemed signed); and/or
 - (h) any Ballot not marked to accept or reject the Plan or any Ballot marked both to accept and reject the Plan.

7. The method of delivery of Ballots to the Solicitation Agent is at the election and risk of each Holder of an Interest. Except as otherwise provided herein, such delivery will be deemed made only when the Solicitation Agent *actually receives* the originally executed Ballot. In all cases, Holders should allow sufficient time to assure timely delivery.
8. If multiple Ballots are received from the same Holder of an Interest with respect to the same Interest prior to the Voting Deadline, the latest, timely received, and properly completed Ballot will supersede and revoke any earlier received Ballots.
9. You must vote all of your Interests in the above-referenced class, regardless if such Interests are asserted against one or multiple Debtors, either to accept or reject the Plan and may *not* split your vote.
10. This Ballot does *not* constitute, and shall not be deemed to be, (a) a Proof of Interest or (b) an assertion or admission of an Interest.
11. **Please be sure to sign and date your Ballot.** If you are signing a Ballot in your capacity as a trustee, executor, administrator, guardian, attorney in fact, officer of a corporation, or otherwise acting in a fiduciary or representative capacity, you must indicate such capacity when signing and, if required or requested by the Solicitation Agent, the Debtors, or the Court, must submit proper evidence to the requesting party to so act on behalf of such Holder. In addition, please provide your name and mailing address if it is different from that set forth on the attached mailing label or if no such mailing label is attached to the ballot.

PLEASE SUBMIT YOUR BALLOT PROMPTLY

IF YOU HAVE ANY QUESTIONS REGARDING THIS BALLOT, THESE VOTING INSTRUCTIONS, OR THE PROCEDURES FOR VOTING, PLEASE CALL THE SOLICITATION AGENT AT:

U.S. TOLL FREE: (888) 508-2507

OR EMAIL GWGINFO@DONLINRECANO.COM

IF THE SOLICITATION AGENT DOES NOT ACTUALLY RECEIVE THIS BALLOT ON OR BEFORE THE VOTING DEADLINE, WHICH IS ON MAY 31, 2023 AT 4:00 P.M., PREVAILING CENTRAL TIME, AND IF THE VOTING DEADLINE IS NOT EXTENDED, YOUR VOTE TRANSMITTED HEREBY MAY BE COUNTED ONLY IN THE DISCRETION OF THE DEBTORS.

Exhibit 3E

**Form of Master Ballot
Class 8, 9, and 10 Interests**

**IN THE UNITED STATES BANKRUPTCY COURT
FOR THE SOUTHERN DISTRICT OF TEXAS
HOUSTON DIVISION**

In re:)	Chapter 11
GWG Holdings, Inc., <i>et al.</i> , ¹)	Case No. 22-90032 (MI)
Debtors.)	(Jointly Administered)

**MASTER BALLOT FOR ACCEPTING OR REJECTING
THE DEBTORS' SECOND AMENDED JOINT CHAPTER 11 PLAN**

CLASS [●]: [●]

**PLEASE READ AND FOLLOW THE ENCLOSED INSTRUCTIONS FOR
COMPLETING BALLOTS CAREFULLY BEFORE COMPLETING THIS BALLOT.**

**FOR YOUR VOTE TO BE COUNTED, THIS BALLOT MUST BE COMPLETED,
EXECUTED, AND RETURNED SO AS TO BE ACTUALLY RECEIVED BY THE
SOLICITATION AGENT BY MAY 31, 2023 AT 4:00 P.M. (PREVAILING CENTRAL
TIME) THE ("VOTING DEADLINE"). IF THIS BALLOT IS NOT PROPERLY
COMPLETED, EXECUTED, AND RECEIVED BY THE SOLICITATION AGENT ON
OR BEFORE THE VOTING DEADLINE, THEN THE VOTES TRANSMITTED BY
THIS BALLOT WILL NOT BE COUNTED.**

ACCESS TO SOLICITATION MATERIALS:

**THE PLAN, DISCLOSURE STATEMENT, AND DISCLOSURE STATEMENT
ORDER, INCLUDING THE SOLICITATION PROCEDURES AND THE
BONDHOLDER SUMMARY MAY BE ACCESSED FREE OF CHARGE AT
[HTTPS://WWW.DONLINRECANO.COM/CLIENTS/GWG/INDEX](https://www.donlinrecano.com/clients/gwg/index) BY CLICKING
ON THE "SOLICITATION MATERIALS" LINK ON THE WEBSITE'S LEFT HAND
NAVIGATION PANEL.**

**YOU CAN ALSO OBTAIN COPIES IN PAPER FORMAT OF ANY SOLICITATION
MATERIALS (A) FREE OF CHARGE BY (I) ACCESSING THE DEBTORS'
RESTRUCTURING WEBSITE AT**

¹ The Debtors in these chapter 11 cases, along with the last four digits of each Debtor's federal tax identification number, are: GWG Holdings, Inc. (2607); GWG Life, LLC (6955); GWG Life USA, LLC (5538) GWG DLP Funding IV, LLC (2598); GWG DLP Funding VI, LLC (6955) and GWG DLP Funding Holdings VI, LLC (6955). The location of Debtor GWG Holdings, Inc.'s principal place of business and the Debtors' service address is 325 N. St. Paul Street, Suite 2650, Dallas, TX 75201. Further information regarding the Debtors and these chapter 11 cases is available at the website of the Debtors' claims and noticing agent: <https://donlinrecano.com/gwg>.

[HTTPS://WWW.DONLINRECANO.COM/CLIENTS/GWG/INDEX](https://www.donlinrecano.com/clients/gwg/index); (II) WRITING TO DONLIN, RECANO & COMPANY, INC., RE: GWG HOLDINGS, INC., ET AL., P.O. BOX 199043, BLYTHEBOURNE STATION, BROOKLYN, NY 11219; (III) CALLING 1 (888) 508-2507 (U.S. TOLL FREE); OR (IV) EMAILING GWGINFO@DONLINRECANO.COM; OR (B) FOR A FEE VIA PACER AT [HTTPS://ECF.TXSB.USCOURTS.GOV/](https://ecf.txsb.uscourts.gov/).

Solicitation Overview

The above-captioned debtors and debtors in possession (collectively, the “Debtors”), are soliciting votes with respect to the Plan as set forth in the *Disclosure Statement for the Debtors’ Second Amended Joint Chapter 11 Plan* [Docket No. 1682] (as may be amended, supplemented, or modified, the “Disclosure Statement”) and the *Debtors’ Second Amended Joint Chapter 11 Plan* [Docket No. 1678] (as may be amended, supplemented, or modified, the “Plan”).² The Bankruptcy Court for the Southern District of Texas (the “Court”) has approved the Disclosure Statement as containing adequate information pursuant to section 1125 of the Bankruptcy Code, by entry of an order on April 21, 2023 [Docket No. 1681³] (the “Disclosure Statement Order”). Court approval of the Disclosure Statement does not indicate approval of the Plan by the Court.

You are receiving this master ballot (this “Master Ballot”) because you are the Nominee (as defined below) of a Beneficial Holder⁴ of an Interest in Class [●] (the “Voting Class”) as of February 24, 2023 (the “Voting Record Date”).

This Master Ballot is to be used by you as a bank, broker, securities intermediary, registered investment advisor, or other nominee, or an agent of any of the foregoing (each of the foregoing, a “Nominee”); or as the proxy holder of a Nominee for certain Beneficial Holders’ Interests to transmit to the Solicitation Agent the votes of such Beneficial Holders in respect of their Interests to accept or reject the Plan. To use this Master Ballot, you must meet all applicable standards to receive informed consent from the Beneficial Holders for whom you are Nominee. The CUSIP numbers for Interests entitled to vote and of which you are the Nominee are set forth on herein.

The Disclosure Statement describes the rights and treatment for each Class. The Disclosure Statement, the Plan, the Bondholder Summary, and certain other materials (the “Solicitation Package”) have been distributed under separate cover from this Master Ballot. This Master Ballot may not be used for any purpose other than for casting votes to accept or reject the Plan and making

² Capitalized terms used but not otherwise defined herein shall have the meanings ascribed to such terms in the Plan, the Disclosure Statement, or the Disclosure Statement Order, as applicable.

³ As modified pursuant to the order entered at docket 1692.

⁴ “Beneficial Holder” is a beneficial owner of Interests whose Interests have not been satisfied prior to the Voting Record Date pursuant to court order or otherwise, as reflected in the records maintained by the Nominees (as defined herein) holding through the Depository Trust Company or other relevant security depository and/or the applicable indenture trustee, as of the Voting Record Date.

certain certifications with respect thereto. Once completed and returned in accordance with the attached instructions, the votes on the Plan will be counted as set forth herein.

You are authorized to collect votes to accept or to reject the Plan from Beneficial Holders in accordance with your customary practices, including the use of a “voting information form” in lieu of (or in addition to) a Beneficial Holder Ballot, and collecting votes from Beneficial Holders through online voting, by phone, facsimile, or other electronic means.

The Court may confirm the Plan and thereby bind all Beneficial Holders of Claims and Interests. To have the votes of your Beneficial Holders count as either an acceptance or rejection of the Plan, you must complete and return this Master Ballot so that the Solicitation Agent **actually receives** it on or before the Voting Deadline.

**THE VOTING DEADLINE IS 4:00 P.M., PREVAILING CENTRAL TIME,
ON MAY 31, 2023.**

Item 1. Certification of Authority to Vote.

The undersigned certifies that, as of the Voting Record Date, the undersigned (please check the applicable box):

- is the record holder of the Interests listed in Item 2 below, and is a broker, bank, or other Nominee for the beneficial owners of the aggregate principal amount of such Interests; or
- is acting under a power of attorney and/or agency (a copy of which will be provided upon request) granted by a broker, bank, or other Nominee that is the registered holder of the aggregate principal amount of the Interests listed in Item 2 below; or
- has been granted a proxy (an original of which is attached hereto) from a broker, bank, or other Nominee, or a beneficial owner, that is the registered holder of the aggregate principal amount of the Interests listed in Item 2 below, and accordingly, has full power and authority to vote to accept or reject the Plan, on behalf of the beneficial owners of the Interests described in Item 2.

Item 2. Interests in the Voting Class Vote on Plan and Item 3. Releases.

The undersigned transmits the following votes and releases of Beneficial Holders of Interests in the Debtors in the Voting Class as set forth below and certifies that the following Beneficial Holders of the Classes of Interests, as identified by their respective customer account numbers set forth below, are Beneficial Holders of such securities as of the Voting Record Date, and have delivered to the undersigned, as Nominee, Ballots casting such votes.

Indicate in the appropriate column below the aggregate principal amount voted for each account or attach such information to this Master Ballot in the form of the following table. Please note that each Beneficial Holder must vote all of their Interests in the Voting Class either to accept or reject the Plan and may not split such vote. Any Ballot executed by the Beneficial Holder that does not

indicate an acceptance or rejection of the Plan or that indicates both an acceptance and a rejection of the Plan in the Voting Class will not be counted.

CUSIP [●] ⁵				
Your Customer Account Number for Each Beneficial Holder Who Voted in this Plan Class	Number of Shares Held as of the Voting Record Date	Item 2 Indicate the Beneficial placing appropriate vote cast on the Holder Ballot by an "X" in the column below.		
		Accept the Plan	or	Reject the Plan
CLASS [●]: [●]				
1.				
2.				
3.				
4.				
5.				
6.				
TOTALS				

Item 3. Certification as to Transcription of Information from Item 3 of the Ballots as to Interests in Voting Classes Voted Through Other Ballots.

The undersigned certifies that the following information is a true and accurate schedule on which the undersigned has transcribed the information, if any, provided in Item 3 of each Ballot received from a Beneficial Holder. Please use additional sheets of paper if necessary.

Your Customer Account Number for Each Beneficial Holder Who Completed Item 3 of the Ballots	TRANSCRIBE FROM ITEM 3 OF THE BENEFICIAL HOLDER BALLOTS:				Indicate whether Beneficial Holder in each row voted to <u>Accept</u> or <u>Reject</u> the Plan
	Account Number of Other Interests Voted	DTC Participant Name and Number	Number of Shares of Other Interests Voted	CUSIP of Other Interests Voted	
CLASS [●]: [●]					
1.					
2.					

⁵ See Schedule 1 hereto for a complete list of affected CUSIPs.

3.					
4.					
5.					
6.					
7.					
7.					
9.					
10.					

Item 4. Certifications.

Upon execution of this Master Ballot, the undersigned certifies that:

1. it has received a copy (or means to access a copy electronically) of the Disclosure Statement, the Plan, the Ballots, the Bondholder Summary, and the remainder of the Solicitation Package and has delivered the same to the Beneficial Holders of the Interests in the Voting Class listed in Item 2 above or delivered such materials via other customary communications used to solicit or collect votes; and
2. either (a) it has received appropriate voting instructions from each Beneficial Holder listed in Item 2 of this Master Ballot; (b) it is the registered Beneficial Holder of the securities being voted; or (c) it has been expressly authorized under applicable law by each such Beneficial Holder to vote on the Plan; and
3. it has properly disclosed: (a) the number of unique Beneficial Holders who completed Ballots; (b) the respective amounts of the Interests in the Voting Class as set forth in Item 2, as the case may be, by each Beneficial Holder who completed a Ballot; (c) each such Beneficial Holder’s respective vote concerning the Plan; (d) each such Beneficial Holder’s certification as to other Interests voted; and (e) the customer account or other identification number for each such Beneficial Holder; and
4. it will maintain Ballots and evidence of separate transactions returned by Beneficial Holders (whether properly completed or defective) for at least one year after the Effective Date and disclose all such information to the Bankruptcy Court or the Debtors, as the case may be, if requested.

Name of Nominee: _____
(Print or type)

DTC Participant Number: _____

Name of Proxy Holder or Agent
for Nominee (if applicable): _____

(Print or type)

Signature: _____

Name of Signatory: _____

Title: _____

Address: _____

Date Completed: _____

Email Address: _____

THIS MASTER BALLOT MUST BE ACTUALLY RECEIVED BY THE VOTING DEADLINE, WHICH IS 4:00 P.M., PREVAILING CENTRAL TIME, ON MAY 31, 2023.

PLEASE COMPLETE AND DATE THE MASTER BALLOT AND RETURN IT PROMPTLY WITH AN ORIGINAL SIGNED COPY IN THE ENVELOPE PROVIDED, OR BY REGULAR MAIL, OVERNIGHT COURIER, OR HAND DELIVERY TO THE ADDRESS BELOW, OR BY EMAIL (INSTRUCTIONS BELOW) SO THAT IT IS ACTUALLY RECEIVED BY THE SOLICITATION AGENT BY THE VOTING DEADLINE.

Via Paper Ballot. Complete, sign, and date this Ballot and return it (with an original signature) promptly in the envelope provided or:

By First Class Mail to:

GWG HOLDINGS, INC., ET AL. Balloting Center
c/o Donlin Recano Company
Attn: Voting Department
P.O. Box 199043 Blythebourne Station
Brooklyn, NY 11219

By Hand Delivery or Overnight Mail to:

GWG HOLDINGS, INC., ET AL. Balloting Center
c/o Donlin Recano Company
Attn: Voting Department
6201 15th Ave
Brooklyn, NY 11219

OR

By electronic mail:

Submit your Master Ballot via electronic mail to GWGVote@donlinrecano.com with “GWG Holdings, Inc. Class [●] Master Ballot” in the subject line.

IMPORTANT NOTE: For any ballot cast via electronic mail, a format of the attachment must be found in the common workplace and industry standard format (i.e., industry-standard pdf file) and the received date and time in the solicitation agent’s inbox will be used as a timestamp for receipt.

Nominees that cast a Master Ballot via electronic mail should NOT also submit a paper Master Ballot.

IF YOU HAVE ANY QUESTIONS ABOUT THE SOLICITATION OR VOTING PROCESS, PLEASE CONTACT THE SOLICITATION AGENT TOLL FREE AT (888)

508-2507; OR EMAILING GWGINFO@DONLINRECANO.COM. ANY BALLOT RECEIVED AFTER THE VOTING DEADLINE OR OTHERWISE NOT IN COMPLIANCE WITH THE DISCLOSURE STATEMENT ORDER WILL NOT BE COUNTED.

MASTER BALLOTS WILL NOT BE ACCEPTED BY TELECOPY, FACSIMILE, OR OTHER ELECTRONIC MEANS OF TRANSMISSION (OTHER THAN BY E-MAIL TO GWGVOTE@DONLINRECANO.COM WITH A REFERENCE TO “GWG HOLDINGS, INC. CLASS [●] MASTER BALLOT” IN THE SUBJECT LINE).

THE MASTER BALLOT SHOULD NOT BE SENT TO THE DEBTORS, THE BANKRUPTCY COURT, OR THE DEBTORS’ FINANCIAL OR LEGAL ADVISORS.

VOTING INSTRUCTIONS

1. As described in the Disclosure Statement, the Debtors are soliciting the votes of Beneficial Holders of Interests with respect to the Plan referred to in the Disclosure Statement. Links to the Plan and the Disclosure Statement are included in the Solicitation Package. Capitalized terms used but not defined herein shall have the meanings assigned to them in the Plan.
2. The Plan can be confirmed by the Bankruptcy Court and thereby made binding upon holders of Claims and Interests if it is accepted by the holders of at least two-thirds in amount and more than one-half in number of Claims or at least two thirds in amount of Interests in at least one Class that votes on the Plan and if the Plan otherwise satisfies the requirements for confirmation set forth in section 1129(a) of the Bankruptcy Code.
3. You should immediately distribute the Ballots (or other customary material used to collect votes in lieu of the Ballots) and Solicitation Package to all Beneficial Holders of Interests and take any action required to enable each such Beneficial Holder to timely vote the Interests that it holds. You may distribute the Solicitation Packages to Beneficial Holders, as appropriate, in accordance with your customary practices. You are authorized to collect votes to accept or to reject the Plan from Beneficial Holders in accordance with your customary practices, including the use of a “voting information form” in lieu of (or in addition to) a Ballot, and collecting votes from Beneficial Holders through online voting, by phone, facsimile, or other electronic means. Any Nominee that elects such a procedure shall meet all applicable standards to receive informed consent. Any Ballot returned to you by a Beneficial Holder of an Interest shall not be counted for purposes of accepting or rejecting the Plan until you properly complete and deliver, to the Solicitation Agent, a Master Ballot that reflects the vote of such Beneficial Holders by 4:00 P.M., prevailing Central Time, on May 31, 2023, or otherwise validate the Ballot in a manner acceptable to the Solicitation Agent.

If you are transmitting the votes of any beneficial owners of Claims in Voting Classes, you may either:

- (a) “Pre-validate” the individual Beneficial Holder Ballot contained in the Solicitation Package and then forward the Solicitation Package to the Beneficial Holder of the Interest for voting within three (3) Business Days after the receipt by such Nominee of the Solicitation Package, with the Beneficial Holder then returning the individual Beneficial Holder Ballot directly to the Solicitation Agent in the return envelope to be provided in the Solicitation Package. A Nominee “pre-validates” a Beneficial Holder Ballot by signing the Ballot and including their DTC participant name and DTC participant number; indicating the account number of the Beneficial Holder and the principal amount of the Interest held by the Nominee for such Beneficial Holder, applying a medallion guarantee stamp to the ballot to certify the principal amount of the Interest owned by the Beneficial Holder as of the Voting Record Date and then forwarding the Ballot together with the Solicitation Package to the Beneficial Holder; *provided, however*, that Nominees shall not mark a vote to accept or reject the Plan or complete Item 2 of the Beneficial Holder Ballot prior to

distribution of the Solicitation Packages to Beneficial Holders unless such Nominee is expressly authorized in writing by the Beneficial Holder under applicable law to vote on such Beneficial Holder's behalf. The Beneficial Holder then completes the information requested on the Ballot and returns the Ballot directly to the Solicitation Agent. A list of the Beneficial Holders to whom "pre-validated" Ballots were delivered should be maintained by Nominees for inspection for at least one year from the Effective Date; OR

- (b) Within three (3) Business Days after receipt by such Nominee of the Solicitation Package, forward the Solicitation Package to the Beneficial Holder of the Interest for voting (along with a return envelope provided by and addressed to the Nominee, if applicable), with the beneficial owner then returning the individual Beneficial Holder Ballot to the Nominee; *provided, however*, that Nominees shall not mark a vote to accept or reject the Plan or complete Item 2 of the Beneficial Holder Ballot prior to distribution of the Solicitation Packages to Beneficial Holders unless such Nominee is expressly authorized in writing by the Beneficial Holder under applicable law to vote on such Beneficial Holder's behalf. In such case, the Nominee will tabulate the votes of its respective Beneficial Holders on a Master Ballot that will be provided to the Nominee separately by the Solicitation Agent, in accordance with any instructions set forth in the instructions to the Master Ballot, and then return the Master Ballot to the Solicitation Agent. The Nominee should advise the Beneficial Holders to return their individual Beneficial Holder Ballots to the Nominee by a date calculated by the Nominee to allow it to prepare and return the Master Ballot to the Solicitation Agent so that the Master Ballot is **actually received** by the Solicitation Agent on or before the Voting Deadline.
4. With regard to any Ballots returned to you by a Beneficial Holder, you must: (a) compile and validate the votes and other relevant information of each such Beneficial Holder on the Master Ballot using the customer name or account number assigned by you to each such Beneficial Holder; (b) execute the Master Ballot; (c) transmit such Master Ballot to the Solicitation Agent by the Voting Deadline; and (d) retain such Ballots from Beneficial Holders, whether in hard copy or by electronic direction, in your files for a period of one year after the Effective Date. You may be ordered to produce the Ballots to the Debtors or the Bankruptcy Court.
5. The time by which a Ballot is **actually received** by the Solicitation Agent shall be the time used to determine whether a Ballot has been submitted by the Voting Deadline. **The Voting Deadline is May 31, 2023, at 4:00 P.M., prevailing Central Time.**
6. If a Ballot is received after the Voting Deadline, it will not be counted except as permitted by applicable law or court order. In all cases, Nominees should allow sufficient time to ensure timely delivery. No Ballot should be sent to the Debtors or the Debtors' financial or legal advisors. A Ballot will not be counted unless received by the Solicitation Agent.
7. If multiple Master Ballots are received prior to the Voting Deadline from the same Nominee with respect to the same Ballot belonging to a Beneficial Holder of a Claim, the

- vote on the last properly completed Master Ballot timely received will supersede and revoke the vote of such Beneficial Holder on any earlier received Master Ballot.
8. If a holder holds a Claim or Interest, as applicable, in a Voting Class against multiple Debtors, a vote on their Ballot will apply to all Debtors against whom such holder or Nominee has a Claim or Interest, as applicable, in that Voting Class.
 9. If a voter simultaneously casts inconsistent duplicate Ballots, with respect to the same Claim, such Ballots shall not be counted.
 10. The Ballot is not a letter of transmittal and may not be used for any purpose other than to vote to accept or reject the Plan and to make certain certifications with respect thereto. Accordingly, at this time, creditors should not surrender certificates or instruments representing or evidencing their Interests, and the Debtors will not accept delivery of any such certificates or instruments surrendered together with a Ballot.
 11. The Ballot does not constitute, and shall not be deemed to be: (a) a Proof of Interest; or (b) an assertion or admission with respect to any Interest.
 12. Please be sure to sign and date your Master Ballot. You should indicate that you are signing a Master Ballot in your capacity as a trustee, executor, administrator, guardian, attorney in fact, officer of a corporation, or otherwise acting in a fiduciary or representative capacity and, if required or requested by the Solicitation Agent, the Debtors, or the Bankruptcy Court, must submit proper evidence to the requesting party to so act on behalf of such Beneficial Holder. In addition, please provide your name and mailing address if it is different from that set forth on the attached mailing label or if no such mailing label is attached to the Master Ballot.
 13. If you are both the Nominee and the Beneficial Holder of any of the Interests in the Voting Class and you wish to vote such Interests in the Voting Class, you may return a Master Ballot for such Interests in the Voting Class and you must vote your entire Interests in the Voting Class to either to accept or reject the Plan and may not split your vote. Accordingly, a Ballot, other than a Master Ballot with the votes of multiple holders, that partially rejects and partially accepts the Plan will not be counted.
 14. The following Ballots and Master Ballots shall not be counted in determining the acceptance or rejection of the Plan: (a) any Ballot or Master Ballot that is illegible or contains insufficient information to permit the identification of the Beneficial Holder of the Interests; (b) any Ballot or Master Ballot cast by a Party that does not hold an Interest in a Class that is entitled to vote on the Plan; (c) any unsigned Ballot or Master Ballot; (d) any Ballot or Master Ballot not marked to accept or reject the Plan; and (e) any Ballot or Master Ballot submitted by any party not entitled to cast a vote with respect to the Plan.
 15. For purposes of the numerosity requirement of section 1126(c) of the Bankruptcy Code, separate Claims or Interests held by a single creditor or interest-holder in a particular Class will be aggregated and treated as if such creditor held one Claim or Interest in such Class, and all votes related to such Claim or Interest will be treated as a single vote to accept or reject the Plan; *provided* that if separate affiliated entities hold Claims or Interests in a

particular Class, these Claims or Interests will not be aggregated and will not be treated as if such creditor or interest-holder held one Claim or Interest in such Class, and the vote of each affiliated entity will be counted separately as a vote to accept or reject the Plan.

The following additional rules shall apply to Master Ballots:

16. Votes cast by Beneficial Holders through a Nominee will be applied against the positions held by such entities in the Interests in the Voting Class as of the Voting Record Date, as evidenced by the record and depository listings;
17. Votes submitted by a Nominee, whether pursuant to a Master Ballot or pre-validated Beneficial Holder Ballots, will not be counted in excess of the record amount of the Interests in the Voting Class held by such Nominee;
18. To the extent that conflicting votes or “overvotes” are submitted by a Nominee, whether pursuant to a Master Ballot or pre-validated Beneficial Holder Ballots, the Solicitation Agent will attempt to reconcile discrepancies with the Nominee;
19. To the extent that overvotes on a Master Ballot or pre-validated Beneficial Holder Ballots are not reconcilable prior to the preparation of the vote certification, the Solicitation Agent will apply the votes to accept and reject the Plan in the same proportion as the votes to accept and reject the Plan submitted on the Master Ballot or pre-validated Beneficial Holder Ballots that contained the overvote, but only to the extent of the Nominee’s position in the relevant Claims in the Voting Classes; and
20. For purposes of tabulating votes, each Beneficial Holder holding through a particular account will be deemed to have voted the principal amount relating to its holding in that particular account, although the Solicitation Agent may be asked to adjust such principal amount to reflect the Claim amount.

Important information regarding the release, exculpation, and injunction provisions in the Plan.⁶

Article VIII.C of the Plan contains the following release (the “**Release**”):

PURSUANT TO SECTION 1123(B) OF THE BANKRUPTCY CODE, IN EXCHANGE FOR GOOD AND VALUABLE CONSIDERATION, THE ADEQUACY OF WHICH IS HEREBY CONFIRMED, ON AND AFTER THE EFFECTIVE DATE, EACH RELEASED PARTY (BUT NO NON-RELEASED PARTY) IS, AND IS DEEMED HEREBY TO BE, FULLY, CONCLUSIVELY, ABSOLUTELY, UNCONDITIONALLY, IRREVOCABLY, AND FOREVER RELEASED AND DISCHARGED BY THE DEBTORS, THE WIND DOWN DEBTORS, AND THEIR ESTATES, AND ANY PERSON SEEKING TO EXERCISE THE RIGHTS OF THE DEBTORS OR THEIR ESTATES, INCLUDING ANY SUCCESSORS TO THE DEBTORS OR ANY ESTATES REPRESENTATIVES

⁶ The Plan provisions referenced herein are for summary purposes only and do not include all provisions of the Plan that may affect your rights. If there is any inconsistency between the provisions set forth herein and the Plan, the Plan governs. You should read the Plan before completing this Ballot.

APPOINTED OR SELECTED PURSUANT TO SECTION 1123(B)(3) OF THE BANKRUPTCY CODE, IN EACH CASE ON BEHALF OF THEMSELVES AND THEIR RESPECTIVE SUCCESSORS, ASSIGNS, AND REPRESENTATIVES, AND ANY AND ALL OTHER ENTITIES WHO MAY PURPORT TO ASSERT ANY CAUSE OF ACTION, DIRECTLY OR DERIVATIVELY, BY, THROUGH OR FOR THE DEBTORS OR THEIR ESTATES, FROM ANY AND ALL CLAIMS AND CAUSES OF ACTION, WHETHER KNOWN OR UNKNOWN, INCLUDING ANY DERIVATIVE CLAIMS, ASSERTED OR ASSERTABLE ON BEHALF OF THE DEBTORS, WHETHER KNOWN OR UNKNOWN, FORESEEN OR UNFORESEEN, MATURED OR UNMATURED, EXISTING OR HEREAFTER ARISING, CONTINGENT OR NON-CONTINGENT, IN LAW, EQUITY, CONTRACT, TORT OR OTHERWISE, EXCEPT FOR ANY CLAIMS RELATED TO ANY ACT OR OMISSION THAT IS DETERMINED IN A FINAL ORDER TO HAVE CONSTITUTED ACTUAL FRAUD, WILLFUL MISCONDUCT, INTENTIONAL BREACH OF FIDUCIARY DUTY, OR GROSS NEGLIGENCE, THAT THE DEBTORS, THE WIND DOWN DEBTORS, OR THEIR ESTATES, INCLUDING ANY SUCCESSORS TO THE DEBTORS OR ANY ESTATES REPRESENTATIVE APPOINTED OR SELECTED PURSUANT TO SECTION 1123(B) OF THE BANKRUPTCY CODE, WOULD HAVE BEEN LEGALLY ENTITLED TO ASSERT IN THEIR OWN RIGHT (WHETHER INDIVIDUALLY OR COLLECTIVELY) OR ON BEHALF OF THE HOLDER OF ANY CLAIM OR INTEREST IN, A DEBTOR OR OTHER ENTITY, OR THAT ANY HOLDER OF ANY CLAIM AGAINST, OR INTEREST IN, A DEBTOR OR OTHER ENTITY COULD HAVE ASSERTED ON BEHALF OF THE DEBTORS, BASED ON OR RELATING TO, OR IN ANY MANNER ARISING FROM, IN WHOLE OR IN PART, THE DEBTORS (INCLUDING THE CAPITAL STRUCTURE, MANAGEMENT, OWNERSHIP OR OPERATION THEREOF), THE BUSINESS OR CONTRACTUAL ARRANGEMENT BETWEEN THE DEBTORS AND ANY RELEASED PARTY, ANY SECURITIES ISSUED BY THE DEBTORS AND THE OWNERSHIP THEREOF, THE ASSERTION OR ENFORCEMENT OF RIGHTS AND REMEDIES AGAINST THE DEBTORS, THE DEBTORS' IN- OR OUT-OF-COURT RESTRUCTURING EFFORTS, ANY AVOIDANCE ACTIONS (BUT EXCLUDING AVOIDANCE ACTIONS BROUGHT AS COUNTERCLAIMS OR DEFENSES TO CLAIMS ASSERTED AGAINST THE DEBTORS), INTERCOMPANY TRANSACTIONS BETWEEN OR AMONG A DEBTOR AND ANOTHER DEBTOR, THE FORMULATION, PREPARATION, DISSEMINATION, NEGOTIATION, OR FILING OF THE DISCLOSURE STATEMENT, THE PLAN (INCLUDING, FOR THE AVOIDANCE OF DOUBT, THE PLAN SUPPLEMENT), THE VIDA DIP FINANCING FACILITY, THE VIDA EXIT FINANCING FACILITY, OR ANY WIND DOWN TRANSACTION, CONTRACT, INSTRUMENT, RELEASE, OR OTHER AGREEMENT OR DOCUMENT (INCLUDING ANY LEGAL OPINION REQUESTED BY ANY ENTITY REGARDING ANY TRANSACTION, CONTRACT, INSTRUMENT, DOCUMENT OR OTHER AGREEMENT CONTEMPLATED BY THE PLAN OR THE RELIANCE BY ANY RELEASED PARTY ON THE PLAN OR THE CONFIRMATION ORDER IN LIEU OF SUCH LEGAL OPINION) CREATED OR ENTERED INTO IN CONNECTION WITH THE DISCLOSURE STATEMENT, THE VIDA EXIT FINANCING FACILITY DOCUMENTS, THE PLAN, OR THE PLAN SUPPLEMENT, BEFORE OR DURING THE CHAPTER 11 CASES, THE CHAPTER 11 CASES, THE FILING OF THE CHAPTER 11 CASES, THE PURSUIT OF CONFIRMATION, THE

ADMINISTRATION AND IMPLEMENTATION OF THE PLAN, INCLUDING THE ISSUANCE OR DISTRIBUTION OF SECURITIES PURSUANT TO THE PLAN, OR THE DISTRIBUTION OF PROPERTY UNDER THE PLAN, OR UPON ANY RELATED ACT OR OMISSION, TRANSACTION, AGREEMENT, EVENT, OR OTHER OCCURRENCE RELATED OR RELATING TO ANY OF THE FOREGOING TAKING PLACE ON OR BEFORE THE EFFECTIVE DATE RELATED OR RELATING TO THE FOREGOING INCLUDING ALL RELIEF OBTAINED BY THE DEBTORS IN THE CHAPTER 11 CASES. FOR THE AVOIDANCE OF DOUBT, THE LBM RELEASED PARTIES, TO THE EXTENT THAT LBM HAS NOT WITHDRAWN FROM THE SETTLEMENT DESCRIBED IN ARTICLE IV.I OF THIS PLAN, SHALL CONSTITUTE RELEASED PARTIES WITH RESPECT TO THIS DEBTOR RELEASE.

NOTWITHSTANDING ANYTHING TO THE CONTRARY IN THE FOREGOING, THE RELEASES SET FORTH ABOVE DO NOT RELEASE: (1) POST-EFFECTIVE DATE OBLIGATIONS OF ANY PARTY OR ENTITY UNDER THE PLAN, THE CONFIRMATION ORDER, ANY WIND DOWN TRANSACTION, OR ANY OTHER DOCUMENT, INSTRUMENT, OR AGREEMENT (INCLUDING THOSE SET FORTH IN THE PLAN SUPPLEMENT) EXECUTED TO IMPLEMENT THE PLAN, INCLUDING THE VIDA EXIT FINANCING FACILITY DOCUMENTS, OR ANY CLAIM OR OBLIGATION ARISING UNDER THE PLAN; (2) THE RIGHTS OF ANY HOLDER OF ALLOWED CLAIMS TO RECEIVE DISTRIBUTIONS UNDER THE PLAN; (3) THE RETAINED CAUSES OF ACTION; (4) ANY CLAIMS RELATED TO ANY ACT OR OMISSION THAT IS DETERMINED IN A FINAL ORDER TO HAVE CONSTITUTED ACTUAL FRAUD, WILLFUL MISCONDUCT, INTENTIONAL BREACH OF FIDUCIARY DUTY, OR GROSS NEGLIGENCE; (5) THE DEBTORS' PREPETITION LEGAL COUNSEL SOLELY WITH RESPECT TO CLAIMS OR CAUSES OF ACTION ARISING FROM SUCH COUNSEL'S PREPETITION ADVICE TO THE DEBTORS AND/OR ANY FORMER DIRECTORS OR OFFICERS OF THE DEBTORS OTHER THAN ADVICE DIRECTLY RELATING TO THE PREPARATION AND FILING OF THE CHAPTER 11 CASES (IT BEING UNDERSTOOD ANY PREPETITION ADVICE TO THE DEBTORS RELATING TO PREPETITION TRANSACTIONS BETWEEN THE DEBTORS AND BENEFICIENT SHALL NOT CONSTITUTE ADVICE DIRECTLY RELATING TO THE PREPARATION AND FILING OF THE CHAPTER 11 CASES); OR (6) ANY NON-RELEASED PARTY.

ENTRY OF THE CONFIRMATION ORDER SHALL CONSTITUTE THE BANKRUPTCY COURT'S APPROVAL, PURSUANT TO BANKRUPTCY RULE 9019, OF THE FOREGOING DEBTOR RELEASE, WHICH INCLUDES BY REFERENCE EACH OF THE RELATED PROVISIONS AND DEFINITIONS CONTAINED IN THE PLAN, AND FURTHER, SHALL CONSTITUTE THE BANKRUPTCY COURT'S FINDING THAT THE DEBTOR RELEASE IS: (A) IN EXCHANGE FOR THE GOOD AND VALUABLE CONSIDERATION PROVIDED BY THE RELEASED PARTIES, INCLUDING, WITHOUT LIMITATION, THE RELEASED PARTIES' CONTRIBUTIONS TO FACILITATING THE WIND DOWN TRANSACTIONS AND IMPLEMENTING THE PLAN; (B) A GOOD FAITH SETTLEMENT AND COMPROMISE OF THE CLAIMS RELEASED BY THE DEBTOR RELEASE; (C) IN THE BEST INTERESTS OF THE DEBTORS AND ALL HOLDERS OF CLAIMS AND

INTERESTS; (D) FAIR, EQUITABLE, AND REASONABLE; (E) GIVEN AND MADE AFTER DUE NOTICE AND OPPORTUNITY FOR HEARING; AND (F) A BAR TO ANY OF THE DEBTORS, THE WIND DOWN DEBTORS, OR THE DEBTORS' ESTATES ASSERTING ANY CLAIM OR CAUSE OF ACTION RELEASED PURSUANT TO THE DEBTOR RELEASE.

“RELEASED PARTY” MEANS, COLLECTIVELY, AND IN EACH CASE IN THEIR RESPECTIVE CAPACITIES AS SUCH AND SUBJECT TO THE LIMITATIONS SET FORTH IN ARTICLE VIII.C HEREOF: (A) (I) THE DEBTORS AND THE WIND DOWN DEBTORS, (II) VIDA, (III) THE BONDHOLDER COMMITTEE AND EACH OF ITS MEMBERS, (IV) ANTHONY R. HORTON, IN HIS CAPACITIES AS AN INDEPENDENT DIRECTOR AND DIRECTOR OF THE DEBTORS, (V) JEFFREY S. STEIN, IN HIS CAPACITIES AS AN OFFICER, AN INDEPENDENT DIRECTOR, AND A DIRECTOR OF THE DEBTORS, (VI) MICHAEL A. TUCKER, IN HIS CAPACITY AS AN OFFICER OF THE DEBTORS, (VII) THE DLP INDEPENDENT DIRECTORS, (VIII) FTI CONSULTING, INC., (IX) PJT PARTNERS LP, AND (X) ANY OTHER PROFESSIONAL RETAINED BY THE DEBTORS, THE INDEPENDENT DIRECTORS, THE DLP INDEPENDENT DIRECTORS, OR THE BONDHOLDER COMMITTEE BY ORDER OF THE BANKRUPTCY COURT IN THE CHAPTER 11 CASES OR ANY PROFESSIONAL RETAINED BY ANY OF THE MEMBERS OF THE BONDHOLDER COMMITTEE, EACH IN SUCH CAPACITY; AND (B) SOLELY TO THE EXTENT AND ON THE TERMS AND CONDITIONS SET FORTH IN THIS PLAN, THE LBM RELEASED PARTIES.

“NON-RELEASED PARTIES” SHALL MEAN ANY ENTITIES THAT ARE NOT RELEASED PARTIES, WHICH ENTITIES SHALL INCLUDE, WITHOUT LIMITATION, BENEFICIENT, ITS CURRENT AND FORMER DIRECTORS AND OFFICERS (INCLUDING, WITHOUT LIMITATION, BRADLEY K. HEPPNER, THOMAS O. HICKS, BRUCE W. SCHNITZER, DENNIS P. LOCKHART, AND PETER T. CANGANY), HCLP NOMINEES, L.L.C., THE DEBTORS' FORMER DIRECTORS AND OFFICERS (INCLUDING, WITHOUT LIMITATION, MURRAY HOLLAND AND TIMOTHY EVANS) IN THEIR CAPACITY OR CAPACITIES AS SUCH, AND ANY ENTITIES AFFILIATED WITH OR OTHERWISE RELATED TO THE FOREGOING.

Article VIII.E of the Plan provides for an exculpation of certain parties (the “**Exculpation**”):

EXCEPT AS OTHERWISE EXPRESSLY STATED IN THIS PLAN OR THE CONFIRMATION ORDER, AS OF THE EFFECTIVE DATE, EACH EXCULPATED PARTY SHALL BE DEEMED TO BE RELEASED AND EXCULPATED FROM ANY CLAIM, OBLIGATION, CAUSE OF ACTION, OR LIABILITY FOR ANY EXCULPATED CLAIM, EXCEPT FOR CLAIMS RELATED TO ANY ACT OR OMISSION THAT IS DETERMINED IN A FINAL ORDER TO HAVE CONSTITUTED INTENTIONAL BREACH OF FIDUCIARY DUTY, ACTUAL FRAUD, WILLFUL MISCONDUCT, OR GROSS NEGLIGENCE, BUT IN ALL RESPECTS EACH DEBTOR AND EACH EXCULPATED PARTY SHALL BE ENTITLED TO REASONABLY RELY UPON THE ADVICE OF COUNSEL WITH RESPECT TO THEIR DUTIES AND RESPONSIBILITIES PURSUANT TO THE PLAN. THE EXCULPATED PARTIES

HAVE, AND UPON THE CONSUMMATION OF THE PLAN, SHALL BE DEEMED TO HAVE, PARTICIPATED IN GOOD FAITH AND IN COMPLIANCE WITH APPLICABLE LAW WITH REGARD TO THE RESTRUCTURING OF CLAIMS AND INTERESTS IN THE CHAPTER 11 CASES AND IN CONNECTION WITH THE WIND DOWN TRANSACTIONS, THE NEGOTIATION, FORMULATION, OR PREPARATION OF THE WIND DOWN DOCUMENTS OR RELATED AGREEMENTS, INSTRUMENTS, OR OTHER DOCUMENTS (INCLUDING, FOR THE AVOIDANCE OF DOUBT, PROVIDING ANY LEGAL OPINION REQUESTED BY ANY ENTITY REGARDING ANY TRANSACTION, CONTRACT, INSTRUMENT, DOCUMENT, OR OTHER AGREEMENT CONTEMPLATED BY THE PLAN OR THE RELIANCE BY ANY RELEASED PARTY ON THE PLAN OR THE CONFIRMATION ORDER IN LIEU OF SUCH LEGAL OPINION) IN CONNECTION WITH THE PLAN, AND THE SOLICITATION OF THE PLAN AND DISTRIBUTIONS PURSUANT TO THE PLAN AND, THEREFORE, ARE NOT, AND ON ACCOUNT OF SUCH DISTRIBUTIONS SHALL NOT BE, LIABLE AT ANY TIME FOR THE VIOLATION OF ANY APPLICABLE LAW, RULE, OR REGULATION GOVERNING THE SOLICITATION OF ACCEPTANCES OR REJECTIONS OF THE PLAN OR SUCH DISTRIBUTIONS MADE PURSUANT TO THE PLAN, EXCEPT FOR CLAIMS RELATED TO ANY ACT OR OMISSION THAT IS DETERMINED IN A FINAL ORDER TO HAVE CONSTITUTED INTENTIONAL BREACH OF FIDUCIARY DUTY, ACTUAL FRAUD, WILLFUL MISCONDUCT, OR GROSS NEGLIGENCE. THE DEBTORS AND THE CREDITOR PROPONENTS AGREE THAT (1) NEITHER THE ACT ITSELF OF FILING OR PROSECUTING A MOTION TO APPROVE A SETTLEMENT OF ANY ESTATE CAUSES OF ACTION WITH BENEFICIENT, ANY OF ITS AFFILIATES OR RELATED PARTIES, AND/OR ANY OTHER NON-RELEASED PARTY NOR THE ACT ITSELF OF FILING OR PROSECUTING ANY OBJECTION TO ANY SUCH SETTLEMENT IN AND OF ITSELF CONSTITUTES AN INTENTIONAL BREACH OF FIDUCIARY DUTY, AND (2) ANY CLAIMS THAT THE DEBTORS OR THE CREDITOR PROPONENTS MAY SEEK TO BRING AGAINST ANY EXCULPATED PARTY SHALL BE LIMITED TO ANY ACTIONS OF SUCH EXCULPATED PARTY SOLELY AFTER THE DATE OF EXECUTION OF THE MEDIATION AGREEMENT; PROVIDED THAT ANY SUCH CLAIMS MUST BE FILED EXCLUSIVELY IN THE BANKRUPTCY COURT AND IN ACCORDANCE WITH THE FEDERAL RULES OF CIVIL PROCEDURES, AND SUCH CLAIMS SHALL BE PLED WITH SPECIFICITY WITH RESPECT TO THE WHO, WHAT, WHEN, WHERE, AND HOW OF THE ALLEGED WRONGFUL CONDUCT.

“EXCULPATED PARTY” MEANS, COLLECTIVELY, AND IN EACH CASE, IN THEIR RESPECTIVE CAPACITIES AS SUCH: (A) JEFFREY S. STEIN, IN HIS CAPACITIES AS AN OFFICER, AN INDEPENDENT DIRECTOR, AND A DIRECTOR OF THE DEBTORS; (B) ANTHONY R. HORTON, IN HIS CAPACITIES AS AN INDEPENDENT DIRECTOR AND DIRECTOR OF THE DEBTORS; (C) MICHAEL A. TUCKER, IN HIS CAPACITY AS AN OFFICER OF THE DEBTORS; (D) THE NON-MANAGEMENT DIRECTORS, IN THEIR CAPACITY AS SUCH; (E) THE DLP INDEPENDENT DIRECTORS, IN THEIR CAPACITY AS SUCH; (F) THE MEMBERS OF THE BONDHOLDER COMMITTEE, IN THEIR CAPACITY AS SUCH; (G) ANY PROFESSIONAL RETAINED BY THE DEBTORS, THE INDEPENDENT DIRECTORS,

THE DLP INDEPENDENT DIRECTORS, THE BONDHOLDER COMMITTEE, IN SUCH PROFESSIONALS' CAPACITY AS SUCH; AND (H) ANY PROFESSIONAL RETAINED BY ANY OF THE MEMBERS OF THE BONDHOLDER COMMITTEE, EACH IN SUCH PROFESSIONALS' CAPACITY AS SUCH.

"EXCULPATED CLAIM" MEANS ANY CLAIM RELATED TO ANY ACT OR OMISSION FROM THE PETITION DATE TO THE EFFECTIVE DATE IN CONNECTION WITH, RELATING TO, OR ARISING OUT OF: (A) THE CHAPTER 11 CASES; (B) THE FORMULATION, PREPARATION, DISSEMINATION, OR NEGOTIATION OF ANY DOCUMENT IN CONNECTION WITH THE CHAPTER 11 CASES; (C) ANY CONTRACT, INSTRUMENT, RELEASE, AND/OR OTHER AGREEMENT OR DOCUMENT CREATED OR ENTERED INTO IN CONNECTION WITH THE CHAPTER 11 CASES; (D) THE PURSUIT OF CONSUMMATION; AND/OR (E) THE FILING, ADMINISTRATION, AND/OR IMPLEMENTATION OF THE CHAPTER 11 CASES, OR THE DISTRIBUTION OF PROPERTY IN CONNECTION THEREWITH OR THEREUNDER; PROVIDED, THAT, FOR THE AVOIDANCE OF DOUBT, ANY PREPETITION ADVICE PROVIDED BY ANY LEGAL PROFESSIONALS IN CONNECTION WITH PREPETITION TRANSACTIONS BETWEEN THE DEBTORS AND BENEFICIENT SHALL NOT CONSTITUTE ANY ACT OR OMISSION THAT IS COVERED BY THIS DEFINITION OF EXCULPATED CLAIM; PROVIDED, FURTHER, THAT, NOTWITHSTANDING THE FOREGOING, EXCULPATED CLAIMS SHALL NOT INCLUDE ANYTHING RELATED TO ANY ACT OR OMISSION THAT IS DETERMINED IN A FINAL ORDER TO HAVE CONSTITUTED ACTUAL FRAUD, WILLFUL MISCONDUCT, INTENTIONAL BREACH OF FIDUCIARY DUTY, OR GROSS NEGLIGENCE.

Article VIII.G of the Plan establishes an injunction (the "**Injunction**"):

EXCEPT AS OTHERWISE EXPRESSLY PROVIDED IN THE PLAN OR THE CONFIRMATION ORDER OR FOR OBLIGATIONS OR DISTRIBUTIONS REQUIRED TO BE PAID PURSUANT TO THE PLAN OR THE CONFIRMATION ORDER, ALL ENTITIES WHO HAVE HELD, HOLD, OR MAY HOLD CLAIMS THAT HAVE BEEN RELEASED PURSUANT TO ARTICLE VIII HEREOF ARE PERMANENTLY ENJOINED, FROM AND AFTER THE EFFECTIVE DATE, FROM TAKING ANY OF THE FOLLOWING ACTIONS AGAINST, AS APPLICABLE, THE DEBTORS, THE RELEASED PARTIES, OR THE EXCULPATED PARTIES: (1) COMMENCING OR CONTINUING IN ANY MANNER ANY ACTION OR OTHER PROCEEDING OF ANY KIND ON ACCOUNT OF OR IN CONNECTION WITH OR WITH RESPECT TO ANY OF THE CLAIMS OR INTERESTS RELEASED HEREUNDER; (2) ENFORCING, ATTACHING, COLLECTING, OR RECOVERING BY ANY MANNER OR MEANS ANY JUDGMENT, AWARD, DECREE, OR ORDER AGAINST SUCH ENTITIES ON ACCOUNT OR IN CONNECTION WITH OR WITH RESPECT TO ANY CLAIMS OR INTERESTS RELEASED HEREUNDER; (3) CREATING, PERFECTING, OR ENFORCING ANY LIEN OR ENCUMBRANCE OF ANY KIND AGAINST SUCH ENTITIES OR THE PROPERTY OF SUCH ENTITIES ON ACCOUNT OR IN CONNECTION WITH OR WITH RESPECT TO ANY CLAIMS OR INTERESTS RELEASED HEREUNDER; (4) ASSERTING ANY RIGHT OF SETOFF,

SUBROGATION, OR RECOUPMENT OF ANY KIND AGAINST ANY OBLIGATION DUE FROM SUCH ENTITIES OR AGAINST THE PROPERTY OR THE ESTATES OF SUCH ENTITIES ON ACCOUNT OR IN CONNECTION WITH OR WITH RESPECT TO ANY CLAIMS OR INTERESTS RELEASED HEREUNDER, UNLESS SUCH HOLDER HAS FILED A MOTION REQUESTING THE RIGHT TO PERFORM SUCH SETOFF ON OR BEFORE THE EFFECTIVE DATE, AND NOTWITHSTANDING AN INDICATION OF A CLAIM OR INTEREST OR OTHERWISE THAT SUCH HOLDER ASSERTS, HAS, OR INTENDS TO PRESERVE ANY RIGHT OF SETOFF PURSUANT TO APPLICABLE LAW OR OTHERWISE; AND (5) COMMENCING OR CONTINUING IN ANY MANNER ANY ACTION OR OTHER PROCEEDING OF ANY KIND ON ACCOUNT OF OR IN CONNECTION WITH OR WITH RESPECT TO ANY CLAIMS OR INTERESTS RELEASED OR SETTLED PURSUANT TO THIS PLAN.

UPON ENTRY OF THE CONFIRMATION ORDER, ALL HOLDERS OF CLAIMS AND INTERESTS AND THEIR RESPECTIVE CURRENT AND FORMER EMPLOYEES, AGENTS, OFFICERS, DIRECTORS, PRINCIPALS, AND DIRECT AND INDIRECT AFFILIATES SHALL BE ENJOINED FROM TAKING ANY ACTIONS TO INTERFERE WITH THE IMPLEMENTATION OR CONSUMMATION OF THIS PLAN. EXCEPT AS OTHERWISE SET FORTH IN THE CONFIRMATION ORDER, EACH HOLDER OF AN ALLOWED CLAIM OR ALLOWED INTEREST, AS APPLICABLE, BY ACCEPTING, OR BEING ELIGIBLE TO ACCEPT, DISTRIBUTIONS UNDER THIS PLAN SHALL BE DEEMED TO HAVE CONSENTED TO THE INJUNCTION PROVISIONS SET FORTH HEREIN.

PLEASE SUBMIT YOUR MASTER BALLOT PROMPTLY

IF YOU HAVE ANY QUESTIONS REGARDING THIS MASTER BALLOT, THESE VOTING INSTRUCTIONS, OR THE PROCEDURES FOR VOTING, PLEASE CALL THE SOLICITATION AGENT AT:

U.S. TOLL FREE: (888) 508-2507

OR EMAIL GWGINFO@DONLINRECANO.COM

Schedule 1
CUSIP List (Interests)

<u>Class</u>	<u>CUSIP(s)</u>
Class 8 – Series 1 Preferred Interests	36192A208, 36192A307, 36192A406, 36192A505. 36192A604, 36192A703, 36192A802, 36192A885, 36192A877, 36192A869, 36192A851, 36192A844, 36192A836, 36192A828. 36192A810
Class 9 – Series 2 Preferred Interests	36192A794, 36192A786, 36192A778, 36192A760, 36192A752, 36192A745, 36192A737, 36192A729, 36192A711, 36192A695, 36192A687, 36192A679, 36192A661, 36192A653, 36192A646, 36192A638, 36192A620, 36192A612, 36192A596, 36192A588, 36192A570, 36192A562, 36192A554. 36192A547
Class 10 – Common Stock in GWGH	36192A109

Exhibit 3F

**Form of Beneficial Holder Ballot
Class 8, 9, and 10 Interests**

**IN THE UNITED STATES BANKRUPTCY COURT
FOR THE SOUTHERN DISTRICT OF TEXAS
HOUSTON DIVISION**

In re:)	
)	Chapter 11
GWG Holdings, Inc., <i>et al.</i> , ¹)	Case No. 22-90032 (MI)
Debtors.)	(Jointly Administered)

**BENEFICIAL HOLDER BALLOT FOR VOTING TO ACCEPT OR REJECT
THE DEBTORS' SECOND AMENDED JOINT CHAPTER 11 PLAN**

Class [●]: [●]

PLEASE READ AND FOLLOW THE ENCLOSED INSTRUCTIONS FOR COMPLETING BALLOTS CAREFULLY BEFORE COMPLETING THIS BALLOT.

FOR YOUR VOTE TO BE COUNTED, THIS BALLOT MUST BE COMPLETED, EXECUTED, AND RETURNED SO AS TO BE ACTUALLY RECEIVED BY THE SOLICITATION AGENT BY MAY 31, 2023 AT 4:00 P.M. (PREVAILING CENTRAL TIME) THE ("VOTING DEADLINE"). IF THIS BALLOT IS NOT PROPERLY COMPLETED, EXECUTED, AND RECEIVED BY THE SOLICITATION AGENT ON OR BEFORE THE VOTING DEADLINE, THEN THE VOTES TRANSMITTED BY THIS BALLOT WILL NOT BE COUNTED.

ACCESS TO SOLICITATION MATERIALS:

THE PLAN, DISCLOSURE STATEMENT, AND DISCLOSURE STATEMENT ORDER, INCLUDING THE SOLICITATION PROCEDURES AND THE BONDHOLDER SUMMARY MAY BE ACCESSED FREE OF CHARGE AT [HTTPS://WWW.DONLINRECANO.COM/CLIENTS/GWG/INDEX](https://www.donlinrecano.com/clients/gwg/index) BY CLICKING ON THE "SOLICITATION MATERIALS" LINK ON THE WEBSITE'S LEFT HAND NAVIGATION PANEL.

YOU CAN ALSO OBTAIN COPIES IN PAPER FORMAT OF ANY SOLICITATION MATERIALS (A) FREE OF CHARGE BY (I) ACCESSING THE DEBTORS' RESTRUCTURING WEBSITE AT

¹ The Debtors in these chapter 11 cases, along with the last four digits of each Debtor's federal tax identification number, are: GWG Holdings, Inc. (2607); GWG Life, LLC (6955); GWG Life USA, LLC (5538) GWG DLP Funding IV, LLC (2598); GWG DLP Funding VI, LLC (6955) and GWG DLP Funding Holdings VI, LLC (6955). The location of Debtor GWG Holdings, Inc.'s principal place of business and the Debtors' service address is 325 N. St. Paul Street, Suite 2650, Dallas, TX 75201. Further information regarding the Debtors and these chapter 11 cases is available at the website of the Debtors' claims and noticing agent: <https://donlinrecano.com/gwg>.

[HTTPS://WWW.DONLINRECANO.COM/CLIENTS/GWG/INDEX](https://www.donlinrecano.com/clients/gwg/index); (II) WRITING TO DONLIN, RECANO & COMPANY, INC., RE: GWG HOLDINGS, INC., ET AL., P.O. BOX 199043, BLYTHEBOURNE STATION, BROOKLYN, NY 11219; (III) CALLING 1 (888) 508-2507 (U.S. TOLL FREE); OR (IV) EMAILING GWGINFO@DONLINRECANO.COM; OR (B) FOR A FEE VIA PACER AT [HTTPS://ECF.TXSB.USCOURTS.GOV/](https://ecf.txsb.uscourts.gov/).

Solicitation Overview

The above-captioned debtors and debtors in possession (collectively, the “Debtors”), are soliciting votes with respect to the Plan as set forth in the *Disclosure Statement for the Debtors’ Second Amended Joint Chapter 11 Plan* [Docket No. 1682] (as may be amended, supplemented, or modified, the “Disclosure Statement”) and the *Debtors’ Second Amended Joint Chapter 11 Plan* [Docket No. 1678] (as may be amended, supplemented, or modified, the “Plan”).² The Bankruptcy Court for the Southern District of Texas (the “Court”) has approved the Disclosure Statement as containing adequate information pursuant to section 1125 of the Bankruptcy Code, by entry of an order on April 21, 2023 [Docket No. 1681³] (the “Disclosure Statement Order”). Court approval of the Disclosure Statement does not indicate approval of the Plan by the Court.

Your rights are described in the Plan, the Disclosure Statement, and the related materials. If you would like paper copies of the Plan, Disclosure Statement and other Solicitation Materials, or if you need to obtain additional Solicitation Packages, you may obtain them (a) at no charge from Donlin Recano & Company, Inc. (the “Solicitation Agent”) by: (i) accessing the Debtors’ restructuring website at <https://www.donlinrecano.com/Clients/gwg/Index>; (ii) calling 1 (888) 508-2507 (U.S. toll-free) or (iii) emailing gwginfo@donlinrecano.com; or (b) for a fee via PACER at <https://ecf.txsb.uscourts.gov/>.

You are receiving this ballot (the “Ballot”) because records indicate that, as of February 24, 2023 (the “Voting Record Date”), you are the Beneficial Holder of a Class [●] [●], or an assignee or transferee thereof. Accordingly, you have a right to vote to accept or reject the Plan. As set forth in the Disclosure Statement, the Debtors, the Bondholder Committee, LBM, and the Ad Hoc Committee of Broker/Dealers recommend that you vote to **ACCEPT** the Plan.

If the Plan is confirmed by the Court, it will be binding on you regardless of whether or not you vote or whether you vote to accept or reject the Plan. To have your vote counted, you must complete, sign, and return this Ballot pursuant to the instructions provided by your Nominee so that it is received by the Solicitation Agent no later than the Voting Deadline.

This Ballot may not be used for any purpose other than for casting votes to accept or reject the Plan and making certain certifications with respect to the Plan. If you believe you have received

² Capitalized terms used but not otherwise defined herein shall have the meanings ascribed to such terms in the Plan, Disclosure Statement, or the Disclosure Statement Order, as applicable.

³ As modified pursuant to the order entered at docket 1692.

this Ballot in error, or if you believe you have received the wrong ballot, please contact the Solicitation Agent immediately at the address, telephone number, or email address set forth above.

You should carefully and thoroughly review the Disclosure Statement and Plan before you vote to accept or reject the Plan. You may wish to seek legal advice concerning the Plan and classification and treatment of your Interests under the Plan.

**THE VOTING DEADLINE IS 4:00 P.M., PREVAILING CENTRAL TIME,
ON MAY 31, 2023.**

Item 1. Voting - Complete This Section.

ITEM 1: NUMBER OF SHARES OF INTERESTS	<p>The undersigned hereby certifies that, as of the Voting Record Date, the undersigned was the Beneficial Holder (or authorized signatory for a Beneficial Holder), of Interests in the Voting Class as set forth below (your “Interests”). You may vote to accept or reject the Plan. You must check the applicable box in the right-hand column below to “accept” or “reject” the Plan for the Voting Class in order to have your vote in the Voting Class counted. Please note that you are voting all of your Interests in the Voting Class either to accept or reject the Plan. You may not split your vote in the Voting Class. If you do not indicate that you either accept or reject the Plan in the Voting Class by checking the applicable box below, your vote in the Voting Class will not be counted. If you indicate that you both accept and reject the Plan for the Voting Class by checking both boxes below, your vote in the Voting Class will not be counted. Please note that your vote cast below will be applied in the same manner and in the same amount against each applicable Debtor..</p> <p>The Beneficial Holder of the Interest(s) in the Voting Classes set forth below votes to (<i>please check <u>one and only one</u> box per applicable Voting Interest</i>):</p>		
Voting Class	Description	Number of Shares	Vote to Accept or Reject Plan
Class [●]	[●] CUSIP [_____]	_____	<input type="checkbox"/> ACCEPT (VOTE FOR) THE PLAN <input type="checkbox"/> REJECT (VOTE AGAINST) THE PLAN

Item 2. Important information regarding the release, exculpation, and injunction provisions in the Plan.⁴

Article VIII.C of the Plan contains the following release (the “**Release**”):

⁴ The Plan provisions referenced herein are for summary purposes only and do not include all provisions of the Plan that may affect your rights. If there is any inconsistency between the provisions set forth herein and the Plan, the Plan governs. You should read the Plan before completing this Ballot.

PURSUANT TO SECTION 1123(B) OF THE BANKRUPTCY CODE, IN EXCHANGE FOR GOOD AND VALUABLE CONSIDERATION, THE ADEQUACY OF WHICH IS HEREBY CONFIRMED, ON AND AFTER THE EFFECTIVE DATE, EACH RELEASED PARTY (BUT NO NON-RELEASED PARTY) IS, AND IS DEEMED HEREBY TO BE, FULLY, CONCLUSIVELY, ABSOLUTELY, UNCONDITIONALLY, IRREVOCABLY, AND FOREVER RELEASED AND DISCHARGED BY THE DEBTORS, THE WIND DOWN DEBTORS, AND THEIR ESTATES, AND ANY PERSON SEEKING TO EXERCISE THE RIGHTS OF THE DEBTORS OR THEIR ESTATES, INCLUDING ANY SUCCESSORS TO THE DEBTORS OR ANY ESTATES REPRESENTATIVES APPOINTED OR SELECTED PURSUANT TO SECTION 1123(B)(3) OF THE BANKRUPTCY CODE, IN EACH CASE ON BEHALF OF THEMSELVES AND THEIR RESPECTIVE SUCCESSORS, ASSIGNS, AND REPRESENTATIVES, AND ANY AND ALL OTHER ENTITIES WHO MAY PURPORT TO ASSERT ANY CAUSE OF ACTION, DIRECTLY OR DERIVATIVELY, BY, THROUGH OR FOR THE DEBTORS OR THEIR ESTATES, FROM ANY AND ALL CLAIMS AND CAUSES OF ACTION, WHETHER KNOWN OR UNKNOWN, INCLUDING ANY DERIVATIVE CLAIMS, ASSERTED OR ASSERTABLE ON BEHALF OF THE DEBTORS, WHETHER KNOWN OR UNKNOWN, FORESEEN OR UNFORESEEN, MATURED OR UNMATURED, EXISTING OR HEREAFTER ARISING, CONTINGENT OR NON-CONTINGENT, IN LAW, EQUITY, CONTRACT, TORT OR OTHERWISE, EXCEPT FOR ANY CLAIMS RELATED TO ANY ACT OR OMISSION THAT IS DETERMINED IN A FINAL ORDER TO HAVE CONSTITUTED ACTUAL FRAUD, WILLFUL MISCONDUCT, INTENTIONAL BREACH OF FIDUCIARY DUTY, OR GROSS NEGLIGENCE, THAT THE DEBTORS, THE WIND DOWN DEBTORS, OR THEIR ESTATES, INCLUDING ANY SUCCESSORS TO THE DEBTORS OR ANY ESTATES REPRESENTATIVE APPOINTED OR SELECTED PURSUANT TO SECTION 1123(B) OF THE BANKRUPTCY CODE, WOULD HAVE BEEN LEGALLY ENTITLED TO ASSERT IN THEIR OWN RIGHT (WHETHER INDIVIDUALLY OR COLLECTIVELY) OR ON BEHALF OF THE HOLDER OF ANY CLAIM OR INTEREST IN, A DEBTOR OR OTHER ENTITY, OR THAT ANY HOLDER OF ANY CLAIM AGAINST, OR INTEREST IN, A DEBTOR OR OTHER ENTITY COULD HAVE ASSERTED ON BEHALF OF THE DEBTORS, BASED ON OR RELATING TO, OR IN ANY MANNER ARISING FROM, IN WHOLE OR IN PART, THE DEBTORS (INCLUDING THE CAPITAL STRUCTURE, MANAGEMENT, OWNERSHIP OR OPERATION THEREOF), THE BUSINESS OR CONTRACTUAL ARRANGEMENT BETWEEN THE DEBTORS AND ANY RELEASED PARTY, ANY SECURITIES ISSUED BY THE DEBTORS AND THE OWNERSHIP THEREOF, THE ASSERTION OR ENFORCEMENT OF RIGHTS AND REMEDIES AGAINST THE DEBTORS, THE DEBTORS' IN- OR OUT-OF-COURT RESTRUCTURING EFFORTS, ANY AVOIDANCE ACTIONS (BUT EXCLUDING AVOIDANCE ACTIONS BROUGHT AS COUNTERCLAIMS OR DEFENSES TO CLAIMS ASSERTED AGAINST THE DEBTORS), INTERCOMPANY TRANSACTIONS BETWEEN OR AMONG A DEBTOR AND ANOTHER DEBTOR, THE FORMULATION, PREPARATION, DISSEMINATION, NEGOTIATION, OR FILING OF THE DISCLOSURE STATEMENT, THE PLAN (INCLUDING, FOR THE AVOIDANCE OF DOUBT, THE PLAN SUPPLEMENT), THE VIDA DIP FINANCING FACILITY, THE VIDA EXIT FINANCING FACILITY, OR ANY WIND DOWN TRANSACTION, CONTRACT, INSTRUMENT, RELEASE, OR OTHER

AGREEMENT OR DOCUMENT (INCLUDING ANY LEGAL OPINION REQUESTED BY ANY ENTITY REGARDING ANY TRANSACTION, CONTRACT, INSTRUMENT, DOCUMENT OR OTHER AGREEMENT CONTEMPLATED BY THE PLAN OR THE RELIANCE BY ANY RELEASED PARTY ON THE PLAN OR THE CONFIRMATION ORDER IN LIEU OF SUCH LEGAL OPINION) CREATED OR ENTERED INTO IN CONNECTION WITH THE DISCLOSURE STATEMENT, THE VIDA EXIT FINANCING FACILITY DOCUMENTS, THE PLAN, OR THE PLAN SUPPLEMENT, BEFORE OR DURING THE CHAPTER 11 CASES, THE CHAPTER 11 CASES, THE FILING OF THE CHAPTER 11 CASES, THE PURSUIT OF CONFIRMATION, THE ADMINISTRATION AND IMPLEMENTATION OF THE PLAN, INCLUDING THE ISSUANCE OR DISTRIBUTION OF SECURITIES PURSUANT TO THE PLAN, OR THE DISTRIBUTION OF PROPERTY UNDER THE PLAN, OR UPON ANY RELATED ACT OR OMISSION, TRANSACTION, AGREEMENT, EVENT, OR OTHER OCCURRENCE RELATED OR RELATING TO ANY OF THE FOREGOING TAKING PLACE ON OR BEFORE THE EFFECTIVE DATE RELATED OR RELATING TO THE FOREGOING INCLUDING ALL RELIEF OBTAINED BY THE DEBTORS IN THE CHAPTER 11 CASES. FOR THE AVOIDANCE OF DOUBT, THE LBM RELEASED PARTIES, TO THE EXTENT THAT LBM HAS NOT WITHDRAWN FROM THE SETTLEMENT DESCRIBED IN ARTICLE IV.I OF THIS PLAN, SHALL CONSTITUTE RELEASED PARTIES WITH RESPECT TO THIS DEBTOR RELEASE.

NOTWITHSTANDING ANYTHING TO THE CONTRARY IN THE FOREGOING, THE RELEASES SET FORTH ABOVE DO NOT RELEASE: (1) POST-EFFECTIVE DATE OBLIGATIONS OF ANY PARTY OR ENTITY UNDER THE PLAN, THE CONFIRMATION ORDER, ANY WIND DOWN TRANSACTION, OR ANY OTHER DOCUMENT, INSTRUMENT, OR AGREEMENT (INCLUDING THOSE SET FORTH IN THE PLAN SUPPLEMENT) EXECUTED TO IMPLEMENT THE PLAN, INCLUDING THE VIDA EXIT FINANCING FACILITY DOCUMENTS, OR ANY CLAIM OR OBLIGATION ARISING UNDER THE PLAN; (2) THE RIGHTS OF ANY HOLDER OF ALLOWED CLAIMS TO RECEIVE DISTRIBUTIONS UNDER THE PLAN; (3) THE RETAINED CAUSES OF ACTION; (4) ANY CLAIMS RELATED TO ANY ACT OR OMISSION THAT IS DETERMINED IN A FINAL ORDER TO HAVE CONSTITUTED ACTUAL FRAUD, WILLFUL MISCONDUCT, INTENTIONAL BREACH OF FIDUCIARY DUTY, OR GROSS NEGLIGENCE; (5) THE DEBTORS' PREPETITION LEGAL COUNSEL SOLELY WITH RESPECT TO CLAIMS OR CAUSES OF ACTION ARISING FROM SUCH COUNSEL'S PREPETITION ADVICE TO THE DEBTORS AND/OR ANY FORMER DIRECTORS OR OFFICERS OF THE DEBTORS OTHER THAN ADVICE DIRECTLY RELATING TO THE PREPARATION AND FILING OF THE CHAPTER 11 CASES (IT BEING UNDERSTOOD ANY PREPETITION ADVICE TO THE DEBTORS RELATING TO PREPETITION TRANSACTIONS BETWEEN THE DEBTORS AND BENEFICIENT SHALL NOT CONSTITUTE ADVICE DIRECTLY RELATING TO THE PREPARATION AND FILING OF THE CHAPTER 11 CASES); OR (6) ANY NON-RELEASED PARTY.

ENTRY OF THE CONFIRMATION ORDER SHALL CONSTITUTE THE BANKRUPTCY COURT'S APPROVAL, PURSUANT TO BANKRUPTCY RULE 9019, OF THE FOREGOING DEBTOR RELEASE, WHICH INCLUDES BY REFERENCE

EACH OF THE RELATED PROVISIONS AND DEFINITIONS CONTAINED IN THE PLAN, AND FURTHER, SHALL CONSTITUTE THE BANKRUPTCY COURT'S FINDING THAT THE DEBTOR RELEASE IS: (A) IN EXCHANGE FOR THE GOOD AND VALUABLE CONSIDERATION PROVIDED BY THE RELEASED PARTIES, INCLUDING, WITHOUT LIMITATION, THE RELEASED PARTIES' CONTRIBUTIONS TO FACILITATING THE WIND DOWN TRANSACTIONS AND IMPLEMENTING THE PLAN; (B) A GOOD FAITH SETTLEMENT AND COMPROMISE OF THE CLAIMS RELEASED BY THE DEBTOR RELEASE; (C) IN THE BEST INTERESTS OF THE DEBTORS AND ALL HOLDERS OF CLAIMS AND INTERESTS; (D) FAIR, EQUITABLE, AND REASONABLE; (E) GIVEN AND MADE AFTER DUE NOTICE AND OPPORTUNITY FOR HEARING; AND (F) A BAR TO ANY OF THE DEBTORS, THE WIND DOWN DEBTORS, OR THE DEBTORS' ESTATES ASSERTING ANY CLAIM OR CAUSE OF ACTION RELEASED PURSUANT TO THE DEBTOR RELEASE.

"RELEASED PARTY" MEANS, COLLECTIVELY, AND IN EACH CASE IN THEIR RESPECTIVE CAPACITIES AS SUCH AND SUBJECT TO THE LIMITATIONS SET FORTH IN ARTICLE VIII.C HEREOF: (A) (I) THE DEBTORS AND THE WIND DOWN DEBTORS, (II) VIDA, (III) THE BONDHOLDER COMMITTEE AND EACH OF ITS MEMBERS, (IV) ANTHONY R. HORTON, IN HIS CAPACITIES AS AN INDEPENDENT DIRECTOR AND DIRECTOR OF THE DEBTORS, (V) JEFFREY S. STEIN, IN HIS CAPACITIES AS AN OFFICER, AN INDEPENDENT DIRECTOR, AND A DIRECTOR OF THE DEBTORS, (VI) MICHAEL A. TUCKER, IN HIS CAPACITY AS AN OFFICER OF THE DEBTORS, (VII) THE DLP INDEPENDENT DIRECTORS, (VIII) FTI CONSULTING, INC., (IX) PJT PARTNERS LP, AND (X) ANY OTHER PROFESSIONAL RETAINED BY THE DEBTORS, THE INDEPENDENT DIRECTORS, THE DLP INDEPENDENT DIRECTORS, OR THE BONDHOLDER COMMITTEE BY ORDER OF THE BANKRUPTCY COURT IN THE CHAPTER 11 CASES OR ANY PROFESSIONAL RETAINED BY ANY OF THE MEMBERS OF THE BONDHOLDER COMMITTEE, EACH IN SUCH CAPACITY; AND (B) SOLELY TO THE EXTENT AND ON THE TERMS AND CONDITIONS SET FORTH IN THIS PLAN, THE LBM RELEASED PARTIES.

"NON-RELEASED PARTIES" SHALL MEAN ANY ENTITIES THAT ARE NOT RELEASED PARTIES, WHICH ENTITIES SHALL INCLUDE, WITHOUT LIMITATION, BENEFICIENT, ITS CURRENT AND FORMER DIRECTORS AND OFFICERS (INCLUDING, WITHOUT LIMITATION, BRADLEY K. HEPPNER, THOMAS O. HICKS, BRUCE W. SCHNITZER, DENNIS P. LOCKHART, AND PETER T. CANGANY), HCLP NOMINEES, L.L.C., THE DEBTORS' FORMER DIRECTORS AND OFFICERS (INCLUDING, WITHOUT LIMITATION, MURRAY HOLLAND AND TIMOTHY EVANS) IN THEIR CAPACITY OR CAPACITIES AS SUCH, AND ANY ENTITIES AFFILIATED WITH OR OTHERWISE RELATED TO THE FOREGOING.

Article VIII.E of the Plan provides for an exculpation of certain parties (the "**Exculpation**"):

EXCEPT AS OTHERWISE EXPRESSLY STATED IN THIS PLAN OR THE CONFIRMATION ORDER, AS OF THE EFFECTIVE DATE, EACH EXCULPATED

PARTY SHALL BE DEEMED TO BE RELEASED AND EXCULPATED FROM ANY CLAIM, OBLIGATION, CAUSE OF ACTION, OR LIABILITY FOR ANY EXCULPATED CLAIM, EXCEPT FOR CLAIMS RELATED TO ANY ACT OR OMISSION THAT IS DETERMINED IN A FINAL ORDER TO HAVE CONSTITUTED INTENTIONAL BREACH OF FIDUCIARY DUTY, ACTUAL FRAUD, WILLFUL MISCONDUCT, OR GROSS NEGLIGENCE, BUT IN ALL RESPECTS EACH DEBTOR AND EACH EXCULPATED PARTY SHALL BE ENTITLED TO REASONABLY RELY UPON THE ADVICE OF COUNSEL WITH RESPECT TO THEIR DUTIES AND RESPONSIBILITIES PURSUANT TO THE PLAN. THE EXCULPATED PARTIES HAVE, AND UPON THE CONSUMMATION OF THE PLAN, SHALL BE DEEMED TO HAVE, PARTICIPATED IN GOOD FAITH AND IN COMPLIANCE WITH APPLICABLE LAW WITH REGARD TO THE RESTRUCTURING OF CLAIMS AND INTERESTS IN THE CHAPTER 11 CASES AND IN CONNECTION WITH THE WIND DOWN TRANSACTIONS, THE NEGOTIATION, FORMULATION, OR PREPARATION OF THE WIND DOWN DOCUMENTS OR RELATED AGREEMENTS, INSTRUMENTS, OR OTHER DOCUMENTS (INCLUDING, FOR THE AVOIDANCE OF DOUBT, PROVIDING ANY LEGAL OPINION REQUESTED BY ANY ENTITY REGARDING ANY TRANSACTION, CONTRACT, INSTRUMENT, DOCUMENT, OR OTHER AGREEMENT CONTEMPLATED BY THE PLAN OR THE RELIANCE BY ANY RELEASED PARTY ON THE PLAN OR THE CONFIRMATION ORDER IN LIEU OF SUCH LEGAL OPINION) IN CONNECTION WITH THE PLAN, AND THE SOLICITATION OF THE PLAN AND DISTRIBUTIONS PURSUANT TO THE PLAN AND, THEREFORE, ARE NOT, AND ON ACCOUNT OF SUCH DISTRIBUTIONS SHALL NOT BE, LIABLE AT ANY TIME FOR THE VIOLATION OF ANY APPLICABLE LAW, RULE, OR REGULATION GOVERNING THE SOLICITATION OF ACCEPTANCES OR REJECTIONS OF THE PLAN OR SUCH DISTRIBUTIONS MADE PURSUANT TO THE PLAN, EXCEPT FOR CLAIMS RELATED TO ANY ACT OR OMISSION THAT IS DETERMINED IN A FINAL ORDER TO HAVE CONSTITUTED INTENTIONAL BREACH OF FIDUCIARY DUTY, ACTUAL FRAUD, WILLFUL MISCONDUCT, OR GROSS NEGLIGENCE. THE DEBTORS AND THE CREDITOR PROPONENTS AGREE THAT (1) NEITHER THE ACT ITSELF OF FILING OR PROSECUTING A MOTION TO APPROVE A SETTLEMENT OF ANY ESTATE CAUSES OF ACTION WITH BENEFICIENT, ANY OF ITS AFFILIATES OR RELATED PARTIES, AND/OR ANY OTHER NON-RELEASED PARTY NOR THE ACT ITSELF OF FILING OR PROSECUTING ANY OBJECTION TO ANY SUCH SETTLEMENT IN AND OF ITSELF CONSTITUTES AN INTENTIONAL BREACH OF FIDUCIARY DUTY, AND (2) ANY CLAIMS THAT THE DEBTORS OR THE CREDITOR PROPONENTS MAY SEEK TO BRING AGAINST ANY EXCULPATED PARTY SHALL BE LIMITED TO ANY ACTIONS OF SUCH EXCULPATED PARTY SOLELY AFTER THE DATE OF EXECUTION OF THE MEDIATION AGREEMENT; PROVIDED THAT ANY SUCH CLAIMS MUST BE FILED EXCLUSIVELY IN THE BANKRUPTCY COURT AND IN ACCORDANCE WITH THE FEDERAL RULES OF CIVIL PROCEDURES, AND SUCH CLAIMS SHALL BE PLED WITH SPECIFICITY

WITH RESPECT TO THE WHO, WHAT, WHEN, WHERE, AND HOW OF THE ALLEGED WRONGFUL CONDUCT.

“EXCULPATED PARTY” MEANS, COLLECTIVELY, AND IN EACH CASE, IN THEIR RESPECTIVE CAPACITIES AS SUCH: (A) JEFFREY S. STEIN, IN HIS CAPACITIES AS AN OFFICER, AN INDEPENDENT DIRECTOR, AND A DIRECTOR OF THE DEBTORS; (B) ANTHONY R. HORTON, IN HIS CAPACITIES AS AN INDEPENDENT DIRECTOR AND DIRECTOR OF THE DEBTORS; (C) MICHAEL A. TUCKER, IN HIS CAPACITY AS AN OFFICER OF THE DEBTORS; (D) THE NON-MANAGEMENT DIRECTORS, IN THEIR CAPACITY AS SUCH; (E) THE DLP INDEPENDENT DIRECTORS, IN THEIR CAPACITY AS SUCH; (F) THE MEMBERS OF THE BONDHOLDER COMMITTEE, IN THEIR CAPACITY AS SUCH; (G) ANY PROFESSIONAL RETAINED BY THE DEBTORS, THE INDEPENDENT DIRECTORS, THE DLP INDEPENDENT DIRECTORS, THE BONDHOLDER COMMITTEE, IN SUCH PROFESSIONALS’ CAPACITY AS SUCH; AND (H) ANY PROFESSIONAL RETAINED BY ANY OF THE MEMBERS OF THE BONDHOLDER COMMITTEE, EACH IN SUCH PROFESSIONALS’ CAPACITY AS SUCH.

“EXCULPATED CLAIM” MEANS ANY CLAIM RELATED TO ANY ACT OR OMISSION FROM THE PETITION DATE TO THE EFFECTIVE DATE IN CONNECTION WITH, RELATING TO, OR ARISING OUT OF: (A) THE CHAPTER 11 CASES; (B) THE FORMULATION, PREPARATION, DISSEMINATION, OR NEGOTIATION OF ANY DOCUMENT IN CONNECTION WITH THE CHAPTER 11 CASES; (C) ANY CONTRACT, INSTRUMENT, RELEASE, AND/OR OTHER AGREEMENT OR DOCUMENT CREATED OR ENTERED INTO IN CONNECTION WITH THE CHAPTER 11 CASES; (D) THE PURSUIT OF CONSUMMATION; AND/OR (E) THE FILING, ADMINISTRATION, AND/OR IMPLEMENTATION OF THE CHAPTER 11 CASES, OR THE DISTRIBUTION OF PROPERTY IN CONNECTION THEREWITH OR THEREUNDER; PROVIDED, THAT, FOR THE AVOIDANCE OF DOUBT, ANY PREPETITION ADVICE PROVIDED BY ANY LEGAL PROFESSIONALS IN CONNECTION WITH PREPETITION TRANSACTIONS BETWEEN THE DEBTORS AND BENEFICIENT SHALL NOT CONSTITUTE ANY ACT OR OMISSION THAT IS COVERED BY THIS DEFINITION OF EXCULPATED CLAIM; PROVIDED, FURTHER, THAT, NOTWITHSTANDING THE FOREGOING, EXCULPATED CLAIMS SHALL NOT INCLUDE ANYTHING RELATED TO ANY ACT OR OMISSION THAT IS DETERMINED IN A FINAL ORDER TO HAVE CONSTITUTED ACTUAL FRAUD, WILLFUL MISCONDUCT, INTENTIONAL BREACH OF FIDUCIARY DUTY, OR GROSS NEGLIGENCE.

Article VIII.G of the Plan establishes an injunction (the “**Injunction**”):

EXCEPT AS OTHERWISE EXPRESSLY PROVIDED IN THE PLAN OR THE CONFIRMATION ORDER OR FOR OBLIGATIONS OR DISTRIBUTIONS REQUIRED TO BE PAID PURSUANT TO THE PLAN OR THE CONFIRMATION ORDER, ALL ENTITIES WHO HAVE HELD, HOLD, OR MAY HOLD CLAIMS THAT HAVE BEEN RELEASED PURSUANT TO ARTICLE VIII HEREOF ARE PERMANENTLY ENJOINED, FROM AND AFTER THE EFFECTIVE DATE, FROM TAKING ANY OF

THE FOLLOWING ACTIONS AGAINST, AS APPLICABLE, THE DEBTORS, THE RELEASED PARTIES, OR THE EXCULPATED PARTIES: (1) COMMENCING OR CONTINUING IN ANY MANNER ANY ACTION OR OTHER PROCEEDING OF ANY KIND ON ACCOUNT OF OR IN CONNECTION WITH OR WITH RESPECT TO ANY OF THE CLAIMS OR INTERESTS RELEASED HEREUNDER; (2) ENFORCING, ATTACHING, COLLECTING, OR RECOVERING BY ANY MANNER OR MEANS ANY JUDGMENT, AWARD, DECREE, OR ORDER AGAINST SUCH ENTITIES ON ACCOUNT OR IN CONNECTION WITH OR WITH RESPECT TO ANY CLAIMS OR INTERESTS RELEASED HEREUNDER; (3) CREATING, PERFECTING, OR ENFORCING ANY LIEN OR ENCUMBRANCE OF ANY KIND AGAINST SUCH ENTITIES OR THE PROPERTY OF SUCH ENTITIES ON ACCOUNT OR IN CONNECTION WITH OR WITH RESPECT TO ANY CLAIMS OR INTERESTS RELEASED HEREUNDER; (4) ASSERTING ANY RIGHT OF SETOFF, SUBROGATION, OR RECOUPMENT OF ANY KIND AGAINST ANY OBLIGATION DUE FROM SUCH ENTITIES OR AGAINST THE PROPERTY OR THE ESTATES OF SUCH ENTITIES ON ACCOUNT OR IN CONNECTION WITH OR WITH RESPECT TO ANY CLAIMS OR INTERESTS RELEASED HEREUNDER, UNLESS SUCH HOLDER HAS FILED A MOTION REQUESTING THE RIGHT TO PERFORM SUCH SETOFF ON OR BEFORE THE EFFECTIVE DATE, AND NOTWITHSTANDING AN INDICATION OF A CLAIM OR INTEREST OR OTHERWISE THAT SUCH HOLDER ASSERTS, HAS, OR INTENDS TO PRESERVE ANY RIGHT OF SETOFF PURSUANT TO APPLICABLE LAW OR OTHERWISE; AND (5) COMMENCING OR CONTINUING IN ANY MANNER ANY ACTION OR OTHER PROCEEDING OF ANY KIND ON ACCOUNT OF OR IN CONNECTION WITH OR WITH RESPECT TO ANY CLAIMS OR INTERESTS RELEASED OR SETTLED PURSUANT TO THIS PLAN.

UPON ENTRY OF THE CONFIRMATION ORDER, ALL HOLDERS OF CLAIMS AND INTERESTS AND THEIR RESPECTIVE CURRENT AND FORMER EMPLOYEES, AGENTS, OFFICERS, DIRECTORS, PRINCIPALS, AND DIRECT AND INDIRECT AFFILIATES SHALL BE ENJOINED FROM TAKING ANY ACTIONS TO INTERFERE WITH THE IMPLEMENTATION OR CONSUMMATION OF THIS PLAN. EXCEPT AS OTHERWISE SET FORTH IN THE CONFIRMATION ORDER, EACH HOLDER OF AN ALLOWED CLAIM OR ALLOWED INTEREST, AS APPLICABLE, BY ACCEPTING, OR BEING ELIGIBLE TO ACCEPT, DISTRIBUTIONS UNDER THIS PLAN SHALL BE DEEMED TO HAVE CONSENTED TO THE INJUNCTION PROVISIONS SET FORTH HEREIN.

Item 3. Certification of Interests in the Voting Class Held in Additional Accounts.

By completing and returning this Ballot, the Beneficial Holder of the Interests identified in Item 1 certifies that this Ballot is the only Ballot submitted for the Interests in the Voting Class identified in Item 1 owned by such Beneficial Holder as indicated in Item 1, except for the Interests identified in the following table. **To be clear, if any Beneficial Holder holds Interests in a Voting Class through one or more Nominees, such Beneficial Holder must identify all Interests in the Voting Class held through its own name and/or each Nominee in the following table, and must indicate the same vote to accept or reject the Plan on all Ballots submitted.**

ONLY COMPLETE ITEM 3 IF YOU HAVE SUBMITTED OTHER BALLOTS ON ACCOUNT OF THE SAME VOTING CLASS

Account Number of Other Interests Voted in the Voting Class	Name of Owner ⁵	Number of Shares of Other Interests Voted in the Voting Class	CUSIP of Other Interests Voted in the Voting Class	DTC Participant of Interests Voted in the Voting Class
Class [●]: [●]				

Item 4. Certifications.

Upon execution of this Ballot, the undersigned certifies that:

- a. as of the Voting Record Date, the undersigned was the Beneficial Holder (or authorized signatory for a Beneficial Holder with full power and authority to accept or reject the Plan) of the Interests in the Voting Class set forth in Item 1;
- b. the Beneficial Holder has reviewed a copy of the Disclosure Statement, the Plan, and the remainder of the Solicitation Package and acknowledges that the solicitation is being made pursuant to the terms and conditions set forth therein;
- c. the Beneficial Holder has cast the same vote with respect to all of the Beneficial Holder’s Interests in the Voting Class;
- d. the Beneficial Holder understands and acknowledges that if multiple Ballots are submitted voting the Claim set forth in Item 1, only the last properly completed Ballot or Master Ballot voting the Interest and received by the Solicitation Agent before the Voting Deadline shall be deemed to reflect the voter’s intent and thus to supersede and revoke any prior Ballots received by the Solicitation Agent;
- e. the Beneficial Holder understands and acknowledges that the Solicitation Agent may verify the amount of the Interests in the Voting Class set forth in Item 1 held by the Beneficial Holder as of the Voting Record Date with any Nominee through which the Beneficial Holder holds its the Interests in the Voting Classes set forth in Item 1 and by returning an executed Ballot the Beneficial Holder directs any such Nominee to provide any information or comply with any actions requested by the Solicitation Agent to verify the amount set

⁵ Insert your name if the Claims in the respective Voting Class are held by you in your own name or, if held in a street name through a Nominee, insert the name of your broker or bank and their DTC Participant Number.

forth in Item 1 hereof. In the event of a discrepancy regarding such amount that cannot be timely reconciled without undue effort on the part of the Solicitation Agent, the amount shown on the records of the Nominee, if applicable, or the Debtors' records shall control; and

- f. the Beneficial Holder understands and acknowledges that all authority conferred or agreed to be conferred pursuant to this Ballot, and every obligation of the Beneficial Holder hereunder, shall be binding upon the transferees, successors, assigns, heirs, executors, administrators, and legal representatives of the Beneficial Holder and shall not be affected by, and shall survive, the death or incapacity of the Beneficial Holder.

Item 5. Beneficial Holder Information and Signature.

Name of Beneficial Holder: _____
(Print or type)

DTC Participant Number: _____

Signature: _____

Name of Signatory: _____
(if other than Beneficial Holder)

Title: _____

Address: _____

Date Completed: _____

**THE VOTING DEADLINE IS 4:00 P.M., PREVAILING CENTRAL TIME,
ON MAY 31, 2023.**

IF YOU RECEIVED A RETURN ENVELOPE ADDRESSED TO THE SOLICITATION AGENT (DONLIN RECANO & COMPANY, INC.), PLEASE COMPLETE AND DATE THE BALLOT AND RETURN IT PROMPTLY IN THE ENVELOPE PROVIDED SO THAT IT IS ACTUALLY RECEIVED BY THE SOLICITATION AGENT BY THE VOTING DEADLINE.

IF YOU RECEIVED A RETURN ENVELOPE ADDRESSED TO YOUR NOMINEE, PLEASE COMPLETE, SIGN, AND DATE THE BALLOT AND RETURN IT IN THE ENVELOPE PROVIDED OR OTHERWISE IN ACCORDANCE WITH THE INSTRUCTIONS PROVIDED BY YOUR NOMINEE. PLEASE ALLOW SUFFICIENT TIME FOR YOUR BALLOT TO BE INCLUDED ON A MASTER BALLOT COMPLETED BY YOUR NOMINEE. THE MASTER BALLOT MUST BE ACTUALLY RECEIVED BY THE SOLICITATION AGENT ON OR BEFORE THE VOTING DEADLINE.

IF YOU HAVE ANY QUESTIONS ABOUT THIS BALLOT OR THE PLAN SOLICITATION OR YOU NEED ADDITIONAL VOTING MATERIALS, PLEASE CONTACT THE SOLICITATION AGENT TOLL FREE AT (888) 508-2507 OR VIA EMAIL AT GWGINFO@DONLINRECANO.COM. IF YOU HAVE QUESTIONS ABOUT THE VOTING PROCEDURES, PLEASE CONTACT YOUR NOMINEE. ANY BALLOT RECEIVED AFTER THE VOTING DEADLINE OR OTHERWISE NOT IN

COMPLIANCE WITH THE DISCLOSURE STATEMENT ORDER WILL NOT BE COUNTED.

VOTING INSTRUCTIONS

1. As described in the Disclosure Statement, the Debtors are soliciting the votes of Beneficial Holders of Class [●] [●] with respect to the Plan referred to in the Disclosure Statement. Links to the Plan and the Disclosure Statement are included in the Solicitation Package you received with the Ballot. Capitalized terms used but not defined herein shall have the meanings assigned to them in the Plan. **PLEASE READ THE PLAN AND THE DISCLOSURE STATEMENT CAREFULLY BEFORE COMPLETING THIS BENEFICIAL HOLDER BALLOT.** You may wish to seek legal advice concerning the Plan and the treatment of your Interest under the Plan.
2. The Plan can be confirmed by the Bankruptcy Court and thereby made binding upon holders of Claims and Interests if it is accepted by the holders of at least two-thirds in amount and more than one-half in number of Claims or at least two thirds in amount of Interests in at least one class that votes on the Plan and if the Plan otherwise satisfies the requirements for confirmation set forth in section 1129(a) of the Bankruptcy Code.
3. To ensure that your vote is counted, you must: (a) complete the Ballot; (b) indicate your decision either to accept or reject the Plan in Item 1 of the Ballot; and (c) **sign and return the Ballot in accordance with the instructions received, so that this Ballot (if “pre-validated” by your Nominee) or a Master Ballot cast on your behalf is actually received by the Solicitation Agent by the Voting Deadline.** If you are returning your Ballot to the Nominee that provided you with this Ballot, your completed Ballot must be sent to your Nominee, allowing sufficient time for your Nominee to receive your Ballot, complete a Master Ballot, and transmit the Master Ballot to the Solicitation Agent so that it is actually received by the Voting Deadline. Your Nominee is authorized to disseminate Solicitation Packages and voting instructions to, and collect voting information from, Beneficial Holders according to its customary practices.

The Solicitation Agent will not accept Beneficial Holder Ballots by facsimile or other electronic means (other than by email at GWGVote@donlinrecano.com for pre-validated Beneficial Holder Ballots and Master Ballots only). If you are directed by your Nominee to submit the Beneficial Holder Ballot to the Nominee via electronic means, such instructions to your Nominee shall have the same effect as if you had completed and returned a physical Beneficial Holder Ballot, including all certifications.
4. The time by which a Ballot or Master Ballot including your vote is **actually received** by the Solicitation Agent shall be the time used to determine whether a Ballot has been submitted by the Voting Deadline. **The Voting Deadline is May 31, 2023, at 4:00 P.M., prevailing Central Time.**
5. If a Ballot is received after the Voting Deadline, it will not be counted except as permitted by applicable law or court order. In all cases, Beneficial Holders should allow sufficient time to assure timely delivery. No Ballot should be sent to the Debtors or the Debtors’ financial or legal advisors. A Ballot will not be counted unless received by the Solicitation Agent.

6. The Beneficial Holder understands and acknowledges that if multiple Ballots are submitted voting the Interests set forth in Item 1, only the last properly completed Ballot or Master Ballot voting the Interests and received by the Solicitation Agent before the Voting Deadline shall be deemed to reflect the voter's intent and thus to supersede and revoke any prior Ballots received by the Solicitation Agent.
7. If a holder holds a Claim or Interest, as applicable, in a Voting Class against multiple Debtors, a vote on their Ballot will apply to all Debtors against whom such holder or Nominee has a Claim or Interest, as applicable, in that Voting Class.
8. If a Beneficial Holder simultaneously casts inconsistent duplicate Ballots, with respect to the same Interests, such Ballots will not be counted.
9. The Ballot is not a letter of transmittal and may not be used for any purpose other than to vote to accept or reject the Plan and to make certain certifications with respect thereto. Accordingly, at this time, creditors should not surrender certificates or instruments representing or evidencing their Interests, and the Debtors will not accept delivery of any such certificates or instruments surrendered together with a Ballot.
10. The Ballot does not constitute, and shall not be deemed to be: (a) a Proof of Interests; or (b) an assertion or admission with respect to any Interests.
11. Please be sure to sign and date your Ballot. If you are completing the Ballot on behalf of an Entity, indicate your relationship with that Entity and the capacity in which you are signing.
12. You must vote your entire Interests in the Voting Class either to accept or reject the Plan and may not split your vote. Accordingly, a Ballot that partially rejects and partially accepts the Plan as to the Voting Class will not be counted as a vote to accept or reject the Plan as to that Class.
13. Any Ballot that is properly completed, executed, and timely returned to the Debtors that fails to indicate acceptance or rejection of the Plan or that indicates both an acceptance and a rejection of the Plan will not be counted.
14. The following Ballots will not be counted in determining the acceptance or rejection of the Plan: (a) any Ballot that is illegible or contains insufficient information to permit the identification of the Beneficial Holder; (b) any Ballot cast by a Person or Entity that does not hold a Claim or Interest in a Class that is entitled to vote on the Plan; (c) any unsigned Ballot; (d) any Ballot not marked to accept or reject the Plan, or marked both to accept and reject the Plan; and/or (e) any Ballot submitted by a party not entitled to cast a vote with respect to the Plan.
15. If you hold Claims or Interests in more than one Class under the Plan or for different Claims within a Class you may receive more than one Ballot. Each Ballot votes only your Claims or Interests indicated on that Ballot. Please complete and return each Ballot you receive.

16. For purposes of the numerosity requirement of section 1126(c) of the Bankruptcy Code, separate Claims or Interests held by a single creditor or interest-holder in a particular Class will be aggregated and treated as if such creditor held one Claim or Interest in such Class, and all votes related to such Claim or Interest will be treated as a single vote to accept or reject the Plan; *provided* that if separate affiliated entities hold Claims or Interests in a particular Class, these Claims or Interests will not be aggregated and will not be treated as if such creditor or interest-holder held one Claim or Interest in such Class, and the vote of each affiliated entity will be counted separately as a vote to accept or reject the Plan.

PLEASE SUBMIT YOUR BALLOT PROMPTLY

IF YOU HAVE ANY QUESTIONS REGARDING THIS BALLOT, THESE VOTING INSTRUCTIONS, OR THE PROCEDURES FOR VOTING, PLEASE CALL THE SOLICITATION AGENT AT:

U.S. TOLL FREE: (888) 508-2507

OR EMAIL GWGINFO@DONLINRECANO.COM

IF THE SOLICITATION AGENT DOES NOT ACTUALLY RECEIVE THIS BALLOT ON OR BEFORE THE VOTING DEADLINE, WHICH IS ON MAY 31, 2023 AT 4:00 P.M., PREVAILING CENTRAL TIME, AND IF THE VOTING DEADLINE IS NOT EXTENDED, YOUR VOTE TRANSMITTED HEREBY MAY BE COUNTED ONLY IN THE DISCRETION OF THE DEBTORS.

Exhibit 3G

**Form of Ballot
Class 4 General Unsecured Claims**

**IN THE UNITED STATES BANKRUPTCY COURT
FOR THE SOUTHERN DISTRICT OF TEXAS
HOUSTON DIVISION**

In re:)	Chapter 11
)	
GWG Holdings, Inc., <i>et al.</i> , ¹)	Case No. 22-90032 (MI)
)	
Debtors.)	(Jointly Administered)
)	

**CLASS 4 GENERAL UNSECURED CLAIMS
BALLOT FOR ELECTING GUC CONVENIENCE CLASS
TREATMENT OR FOR VOTING TO ACCEPT OR REJECT
THE DEBTORS' SECOND AMENDED JOINT CHAPTER 11 PLAN**

PLEASE READ AND FOLLOW THE ENCLOSED INSTRUCTIONS FOR COMPLETING BALLOTS CAREFULLY BEFORE COMPLETING THIS BALLOT.

FOR YOUR VOTE TO BE COUNTED, THIS BALLOT MUST BE COMPLETED, EXECUTED, AND RETURNED SO AS TO BE ACTUALLY RECEIVED BY THE SOLICITATION AGENT BY MAY 31, 2023 AT 4:00 P.M. (PREVAILING CENTRAL TIME) THE ("VOTING DEADLINE"). IF THIS BALLOT IS NOT PROPERLY COMPLETED, EXECUTED, AND RECEIVED BY THE SOLICITATION AGENT ON OR BEFORE THE VOTING DEADLINE, THEN THE VOTES TRANSMITTED BY THIS BALLOT WILL NOT BE COUNTED.

ACCESS TO SOLICITATION MATERIALS:

THE PLAN, DISCLOSURE STATEMENT, AND DISCLOSURE STATEMENT ORDER, INCLUDING THE SOLICITATION PROCEDURES AND THE BONDHOLDER SUMMARY MAY BE ACCESSED FREE OF CHARGE AT [HTTPS://WWW.DONLINRECANO.COM/CLIENTS/GWG/INDEX](https://www.donlinrecano.com/clients/gwg/index) BY CLICKING ON THE "SOLICITATION MATERIALS" LINK ON THE WEBSITE'S LEFT HAND NAVIGATION PANEL.

YOU CAN ALSO OBTAIN COPIES IN PAPER FORMAT OF ANY SOLICITATION MATERIALS (A) FREE OF CHARGE BY (I) ACCESSING THE DEBTORS' RESTRUCTURING WEBSITE AT

¹ The Debtors in these chapter 11 cases, along with the last four digits of each Debtor's federal tax identification number, are: GWG Holdings, Inc. (2607); GWG Life, LLC (6955); GWG Life USA, LLC (5538) GWG DLP Funding IV, LLC (2598); GWG DLP Funding VI, LLC (6955) and GWG DLP Funding Holdings VI, LLC (6955). The location of Debtor GWG Holdings, Inc.'s principal place of business and the Debtors' service address is 325 N. St. Paul Street, Suite 2650, Dallas, TX 75201. Further information regarding the Debtors and these chapter 11 cases is available at the website of the Debtors' claims and noticing agent: <https://donlinrecano.com/gwg>.

[HTTPS://WWW.DONLINRECANO.COM/CLIENTS/GWG/INDEX](https://www.donlinrecano.com/clients/gwg/index); (II) WRITING TO DONLIN, RECANO & COMPANY, INC., RE: GWG HOLDINGS, INC., ET AL., P.O. BOX 199043, BLYTHEBOURNE STATION, BROOKLYN, NY 11219; (III) CALLING 1 (888) 508-2507 (U.S. TOLL FREE); OR (IV) EMAILING GWGINFO@DONLINRECANO.COM; OR (B) FOR A FEE VIA PACER AT [HTTPS://ECF.TXSB.USCOURTS.GOV/](https://ecf.txsb.uscourts.gov/).

Solicitation Overview

The above-captioned debtors and debtors in possession (collectively, the “Debtors”), are soliciting votes with respect to the Plan as set forth in the *Disclosure Statement for the Debtors’ Second Amended Joint Chapter 11 Plan* [Docket No. 1682] (as may be amended, supplemented, or modified, the “Disclosure Statement”) and the *Debtors’ Second Amended Joint Chapter 11 Plan* [Docket No. 1678] (as may be amended, supplemented, or modified, the “Plan”).² The Bankruptcy Court for the Southern District of Texas (the “Court”) has approved the Disclosure Statement as containing adequate information pursuant to section 1125 of the Bankruptcy Code, by entry of an order on April 21, 2023 [Docket No. 1681³] (the “Disclosure Statement Order”). Court approval of the Disclosure Statement does not indicate approval of the Plan by the Court.

Your rights are described in the Plan, the Disclosure Statement, and the related materials. If you would like paper copies of the Plan, Disclosure Statement, and other Solicitation Materials, or if you need to obtain additional Solicitation Packages, you may obtain them (a) at no charge from Donlin Recano & Company, Inc. (the “Solicitation Agent”) by: (i) accessing the Debtors’ restructuring website at <https://www.donlinrecano.com/Clients/gwg/Index>; (ii) calling 1 (888) 508-2507 (U.S. toll-free) or (iii) emailing gwginfo@donlinrecano.com; or (b) for a fee via PACER at <https://ecf.txsb.uscourts.gov/>.

You are receiving this ballot (the “Ballot”) because records indicate that you are the direct Holder of a Class 4 General Unsecured Claims as of the Voting Record Date (as defined in the Disclosure Statement Order), or an assignee or transferee thereof. Accordingly, you have a right to vote to accept or reject the Plan. As set forth in the Disclosure Statement, the Debtors, the Bondholder Committee, LBM, and the Ad Hoc Committee of Broker/Dealers recommend that you vote to **ACCEPT** the Plan.

If the Plan is confirmed by the Court, it will be binding on you regardless of whether or not you vote or whether you vote to accept or reject the Plan. To have your vote counted, you must complete, sign, and return this Ballot so that it is received by the Solicitation Agent no later than the Voting Deadline.

This Ballot may not be used for any purpose other than for casting votes to accept or reject the Plan and making certain certifications with respect to the Plan. If you believe you have received

² Capitalized terms used but not otherwise defined herein shall have the meanings ascribed to such terms in the Plan, the Disclosure Statement, or the Disclosure Statement Order, as applicable.

³ As modified pursuant to the order entered at docket 1692.

this Ballot in error, or if you believe you have received the wrong ballot, please contact the Solicitation Agent immediately at the address, telephone number, or email address set forth above.

ARTICLE VIII OF THE PLAN CONTAINS RELEASE, EXCULPATION, AND INJUNCTION PROVISIONS.

Submitting Your Ballot

You should review the Plan and the Disclosure Statement and the instructions contained herein before you vote. You may wish to seek legal advice concerning the Plan and the Plan's classification and treatment of your Claim. **THE DEBTORS AND THE SOLICITATION AGENT ARE NOT AUTHORIZED TO PROVIDE, AND WILL NOT PROVIDE, LEGAL ADVICE.**

PLEASE SUBMIT YOUR BALLOT BY *ONLY ONE* OF THE FOLLOWING METHODS:

Via Electronic Mail. Complete, sign, and date this Ballot and email a scanned copy of the ballot in a universally viewable file format such as .PDF to GWGVote@donlinrecano.com.

OR

Via Paper Ballot. Complete, sign, and date this Ballot and return it (with an original signature) promptly in the envelope provided or:

By First Class Mail to:

**GWG HOLDINGS, INC., ET AL. Balloting Center
c/o Donlin Recano Company
Attn: Voting Department
P.O. Box 199043 Blythebourne Station
Brooklyn, NY 11219**

By Hand Delivery or Overnight Mail to:

**GWG HOLDINGS, INC., ET AL. Balloting Center
c/o Donlin Recano Company
Attn: Voting Department
6201 15th Ave
Brooklyn, NY 11219**

OR

Via eBallot Portal:

Ballots may be submitted via an electronic Ballot through the Voting Agent's on-line electronic Ballot submission portal at www.DonlinRecano.com/clients/gwg/vote (the "eBallot Portal") by no later than the Voting Deadline. Any failure to follow the voting instructions included with the Ballot may disqualify your Ballot and your vote.

In order to submit a Ballot through the eBallot Portal, you must use the Unique eBallot ID# assigned to your claim. Please complete and submit an electronic Ballot for each eBallot ID# you receive.

UNIQUE E-BALLOT IDENTIFICATION _____

Each eBallot ID# is to be used solely for voting only those Claims described in Item 1 of your electronic Ballot. Please complete and submit an electronic Ballot for each eBallot ID# you receive, as applicable.

Creditors who cast a Ballot using the E-Ballot Portal should NOT also submit a paper Ballot.

Item 1. GUC Convenience Claim Election

Pursuant and subject to the provisions of the Plan, Holders of Class 4(a) General Unsecured Claims holding Allowed Claims in excess of \$2,750 of may elect to **have such Claim reduced to \$2,750 and treated as an Allowed GUC Convenience Claim** for purposes of the Plan.

If you choose to make such election, your Claim, **as so reduced**, will be unimpaired and you will receive (i) payment in full in Cash of the due and unpaid portion of your Allowed GUC Convenience Claim on the later of (x) the Effective Date of the Plan (or as soon as reasonably practicable thereafter), or (y) as soon as practicable after the date such Claim becomes due and payable, or (ii) such other treatment rendering your Allowed GUC Convenience Claim Unimpaired.

THE HOLDER OF AN ALLOWED GENERAL UNSECURED CLAIM THAT TIMELY ELECTS TO REDUCE THE AMOUNT OF ITS ALLOWED CLAIM SHALL BE DEEMED TO BE THE HOLDER OF AN ALLOWED GUC CONVENIENCE CLAIM FOR CLASSIFICATION, VOTING, AND ALL OTHER PURPOSES UNDER THE PLAN.

IF YOU ELECT TO HAVE YOUR CLASS 4(A) GENERAL UNSECURED CLAIM TREATED AS A CLASS 4(B) GUC CONVENIENCE CLAIM, YOUR CLAIM, AS SO REDUCED, WILL BE UNIMPAIRED UNDER THE PLAN AND, ACCORDINGLY, YOU WILL NO LONGER HAVE THE RIGHT TO VOTE TO ACCEPT OR REJECT THE PLAN.

TO THE EXTENT YOU CHOOSE TO HAVE YOUR CLASS 4(A) GENERAL UNSECURED CLAIM TREATED AS A CLASS 4(B) GUC CONVENIENCE CLAIM, YOU MUST AFFIRMATIVELY ELECT TO DO SO BY CHECKING THE BOX IN THIS ITEM 1.

The Undersigned Holder of the Class 4(a) General Unsecured Claim elects to:

<u>Amount</u>	<u>GUC Convenience Class Election</u>
---------------	---------------------------------------

\$ _____	<input type="checkbox"/> REDUCE its Class 4(a) General Unsecured Claim to \$2,750 and RECEIVE treatment provided to Class 4(b) GUC Convenience Claim on account of such Class 4(a) General Unsecured Claim, as so reduced.
----------	--

PLEASE NOTE THAT ELECTING CLASS 4(B) CONVENIENCE CLASS TREATMENT DOES NOT CONSTITUTE ALLOWANCE OF YOUR CLAIM. THE DEBTORS RESERVE THE RIGHT TO TREAT YOUR CLAIM AS A DISPUTED CLAIM UNDER THE PLAN NOTWITHSTANDING ANY GUC CONVENIENCE CLASS ELECTION WITH RESPECT TO SUCH CLAIM.

Item 2. Amount of Claim.⁴

ONLY COMPLETE ITEMS 2 AND 3 IF YOU DID NOT ELECT TO HAVE YOUR CLASS 4(A) GENERAL UNSECURED CLAIM TREATED AS A CLASS 4(B) GUC CONVENIENCE CLAIM IN ITEM 1 ABOVE.

IF YOU ELECT TO HAVE YOUR CLASS 4(A) GENERAL UNSECURED CLAIM TREATED AS A CLASS 4(B) GUC CONVENIENCE CLAIM IN ITEM 1 ABOVE, SKIP ITEMS 2 AND 3 AND PROCEED TO ITEM 4.

IF YOU COMPLETE ITEMS 2 AND 3 AND YOU ELECT TO HAVE YOUR CLASS 4(A) GENERAL UNSECURED CLAIM TREATED AS A CLASS 4(B) GUC CONVENIENCE CLAIM IN ITEM 1 ABOVE, THE VOTE IN ITEM 3 WILL BE DISREGARDED.

The undersigned hereby certifies that as of the Voting Record Date, the undersigned was the Holder of a Class 4(a) General Unsecured Claim in the following aggregate unpaid amount (insert amount in box below):

_____ Debtor _____

Any admission of Claims for purposes of voting on the Plan is not an admission of liability on the part of the Debtors or any other party for payment purposes. Additionally, The above amount may not be the same as the amount you included in a filed Proof of Claim, and the above amount may exclude accrued interest solely for voting tabulation purposes.

⁴ For voting purposes only, subject to tabulation rules.

Item 3. Vote on Plan.

The Holder of Class 4(a) General Unsecured set forth in Item 2 votes to (please check only one):

<input type="checkbox"/> ACCEPT (vote FOR) the Plan	<input type="checkbox"/> REJECT (vote AGAINST) the Plan
--	--

Item 4. Important information regarding the release, exculpation, and injunction provisions in the Plan.⁵

Article VIII.C of the Plan contains the following release (the “**Release**”):

PURSUANT TO SECTION 1123(B) OF THE BANKRUPTCY CODE, IN EXCHANGE FOR GOOD AND VALUABLE CONSIDERATION, THE ADEQUACY OF WHICH IS HEREBY CONFIRMED, ON AND AFTER THE EFFECTIVE DATE, EACH RELEASED PARTY (BUT NO NON-RELEASED PARTY) IS, AND IS DEEMED HEREBY TO BE, FULLY, CONCLUSIVELY, ABSOLUTELY, UNCONDITIONALLY, IRREVOCABLY, AND FOREVER RELEASED AND DISCHARGED BY THE DEBTORS, THE WIND DOWN DEBTORS, AND THEIR ESTATES, AND ANY PERSON SEEKING TO EXERCISE THE RIGHTS OF THE DEBTORS OR THEIR ESTATES, INCLUDING ANY SUCCESSORS TO THE DEBTORS OR ANY ESTATES REPRESENTATIVES APPOINTED OR SELECTED PURSUANT TO SECTION 1123(B)(3) OF THE BANKRUPTCY CODE, IN EACH CASE ON BEHALF OF THEMSELVES AND THEIR RESPECTIVE SUCCESSORS, ASSIGNS, AND REPRESENTATIVES, AND ANY AND ALL OTHER ENTITIES WHO MAY PURPORT TO ASSERT ANY CAUSE OF ACTION, DIRECTLY OR DERIVATIVELY, BY, THROUGH OR FOR THE DEBTORS OR THEIR ESTATES, FROM ANY AND ALL CLAIMS AND CAUSES OF ACTION, WHETHER KNOWN OR UNKNOWN, INCLUDING ANY DERIVATIVE CLAIMS, ASSERTED OR ASSERTABLE ON BEHALF OF THE DEBTORS, WHETHER KNOWN OR UNKNOWN, FORESEEN OR UNFORESEEN, MATURED OR UNMATURED, EXISTING OR HEREAFTER ARISING, CONTINGENT OR NON-CONTINGENT, IN LAW, EQUITY, CONTRACT, TORT OR OTHERWISE, EXCEPT FOR ANY CLAIMS RELATED TO ANY ACT OR OMISSION THAT IS DETERMINED IN A FINAL ORDER TO HAVE CONSTITUTED ACTUAL FRAUD, WILLFUL MISCONDUCT, INTENTIONAL BREACH OF FIDUCIARY DUTY, OR GROSS NEGLIGENCE, THAT THE DEBTORS, THE WIND DOWN DEBTORS, OR THEIR ESTATES, INCLUDING ANY SUCCESSORS TO THE DEBTORS OR ANY ESTATES REPRESENTATIVE APPOINTED OR SELECTED PURSUANT TO SECTION 1123(B) OF THE BANKRUPTCY CODE, WOULD HAVE BEEN LEGALLY ENTITLED TO ASSERT IN THEIR OWN RIGHT (WHETHER INDIVIDUALLY OR COLLECTIVELY) OR ON BEHALF OF THE HOLDER OF ANY CLAIM OR INTEREST IN, A DEBTOR OR OTHER ENTITY, OR THAT ANY HOLDER OF ANY CLAIM AGAINST, OR INTEREST IN, A DEBTOR OR OTHER ENTITY COULD HAVE ASSERTED ON BEHALF OF THE DEBTORS, BASED

⁵ The Plan provisions referenced herein are for summary purposes only and do not include all provisions of the Plan that may affect your rights. If there is any inconsistency between the provisions set forth herein and the Plan, the Plan governs. You should read the Plan before completing this Ballot.

ON OR RELATING TO, OR IN ANY MANNER ARISING FROM, IN WHOLE OR IN PART, THE DEBTORS (INCLUDING THE CAPITAL STRUCTURE, MANAGEMENT, OWNERSHIP OR OPERATION THEREOF), THE BUSINESS OR CONTRACTUAL ARRANGEMENT BETWEEN THE DEBTORS AND ANY RELEASED PARTY, ANY SECURITIES ISSUED BY THE DEBTORS AND THE OWNERSHIP THEREOF, THE ASSERTION OR ENFORCEMENT OF RIGHTS AND REMEDIES AGAINST THE DEBTORS, THE DEBTORS' IN- OR OUT-OF-COURT RESTRUCTURING EFFORTS, ANY AVOIDANCE ACTIONS (BUT EXCLUDING AVOIDANCE ACTIONS BROUGHT AS COUNTERCLAIMS OR DEFENSES TO CLAIMS ASSERTED AGAINST THE DEBTORS), INTERCOMPANY TRANSACTIONS BETWEEN OR AMONG A DEBTOR AND ANOTHER DEBTOR, THE FORMULATION, PREPARATION, DISSEMINATION, NEGOTIATION, OR FILING OF THE DISCLOSURE STATEMENT, THE PLAN (INCLUDING, FOR THE AVOIDANCE OF DOUBT, THE PLAN SUPPLEMENT), THE VIDA DIP FINANCING FACILITY, THE VIDA EXIT FINANCING FACILITY, OR ANY WIND DOWN TRANSACTION, CONTRACT, INSTRUMENT, RELEASE, OR OTHER AGREEMENT OR DOCUMENT (INCLUDING ANY LEGAL OPINION REQUESTED BY ANY ENTITY REGARDING ANY TRANSACTION, CONTRACT, INSTRUMENT, DOCUMENT OR OTHER AGREEMENT CONTEMPLATED BY THE PLAN OR THE RELIANCE BY ANY RELEASED PARTY ON THE PLAN OR THE CONFIRMATION ORDER IN LIEU OF SUCH LEGAL OPINION) CREATED OR ENTERED INTO IN CONNECTION WITH THE DISCLOSURE STATEMENT, THE VIDA EXIT FINANCING FACILITY DOCUMENTS, THE PLAN, OR THE PLAN SUPPLEMENT, BEFORE OR DURING THE CHAPTER 11 CASES, THE CHAPTER 11 CASES, THE FILING OF THE CHAPTER 11 CASES, THE PURSUIT OF CONFIRMATION, THE ADMINISTRATION AND IMPLEMENTATION OF THE PLAN, INCLUDING THE ISSUANCE OR DISTRIBUTION OF SECURITIES PURSUANT TO THE PLAN, OR THE DISTRIBUTION OF PROPERTY UNDER THE PLAN, OR UPON ANY RELATED ACT OR OMISSION, TRANSACTION, AGREEMENT, EVENT, OR OTHER OCCURRENCE RELATED OR RELATING TO ANY OF THE FOREGOING TAKING PLACE ON OR BEFORE THE EFFECTIVE DATE RELATED OR RELATING TO THE FOREGOING INCLUDING ALL RELIEF OBTAINED BY THE DEBTORS IN THE CHAPTER 11 CASES. FOR THE AVOIDANCE OF DOUBT, THE LBM RELEASED PARTIES, TO THE EXTENT THAT LBM HAS NOT WITHDRAWN FROM THE SETTLEMENT DESCRIBED IN ARTICLE IV.I OF THIS PLAN, SHALL CONSTITUTE RELEASED PARTIES WITH RESPECT TO THIS DEBTOR RELEASE.

NOTWITHSTANDING ANYTHING TO THE CONTRARY IN THE FOREGOING, THE RELEASES SET FORTH ABOVE DO NOT RELEASE: (1) POST-EFFECTIVE DATE OBLIGATIONS OF ANY PARTY OR ENTITY UNDER THE PLAN, THE CONFIRMATION ORDER, ANY WIND DOWN TRANSACTION, OR ANY OTHER DOCUMENT, INSTRUMENT, OR AGREEMENT (INCLUDING THOSE SET FORTH IN THE PLAN SUPPLEMENT) EXECUTED TO IMPLEMENT THE PLAN, INCLUDING THE VIDA EXIT FINANCING FACILITY DOCUMENTS, OR ANY CLAIM OR OBLIGATION ARISING UNDER THE PLAN; (2) THE RIGHTS OF ANY HOLDER OF ALLOWED CLAIMS TO RECEIVE DISTRIBUTIONS UNDER THE PLAN; (3) THE RETAINED CAUSES OF ACTION; (4) ANY CLAIMS RELATED TO ANY ACT OR OMISSION THAT IS DETERMINED IN A FINAL ORDER TO HAVE CONSTITUTED

ACTUAL FRAUD, WILLFUL MISCONDUCT, INTENTIONAL BREACH OF FIDUCIARY DUTY, OR GROSS NEGLIGENCE; (5) THE DEBTORS' PREPETITION LEGAL COUNSEL SOLELY WITH RESPECT TO CLAIMS OR CAUSES OF ACTION ARISING FROM SUCH COUNSEL'S PREPETITION ADVICE TO THE DEBTORS AND/OR ANY FORMER DIRECTORS OR OFFICERS OF THE DEBTORS OTHER THAN ADVICE DIRECTLY RELATING TO THE PREPARATION AND FILING OF THE CHAPTER 11 CASES (IT BEING UNDERSTOOD ANY PREPETITION ADVICE TO THE DEBTORS RELATING TO PREPETITION TRANSACTIONS BETWEEN THE DEBTORS AND BENEFICIENT SHALL NOT CONSTITUTE ADVICE DIRECTLY RELATING TO THE PREPARATION AND FILING OF THE CHAPTER 11 CASES); OR (6) ANY NON-RELEASED PARTY.

ENTRY OF THE CONFIRMATION ORDER SHALL CONSTITUTE THE BANKRUPTCY COURT'S APPROVAL, PURSUANT TO BANKRUPTCY RULE 9019, OF THE FOREGOING DEBTOR RELEASE, WHICH INCLUDES BY REFERENCE EACH OF THE RELATED PROVISIONS AND DEFINITIONS CONTAINED IN THE PLAN, AND FURTHER, SHALL CONSTITUTE THE BANKRUPTCY COURT'S FINDING THAT THE DEBTOR RELEASE IS: (A) IN EXCHANGE FOR THE GOOD AND VALUABLE CONSIDERATION PROVIDED BY THE RELEASED PARTIES, INCLUDING, WITHOUT LIMITATION, THE RELEASED PARTIES' CONTRIBUTIONS TO FACILITATING THE WIND DOWN TRANSACTIONS AND IMPLEMENTING THE PLAN; (B) A GOOD FAITH SETTLEMENT AND COMPROMISE OF THE CLAIMS RELEASED BY THE DEBTOR RELEASE; (C) IN THE BEST INTERESTS OF THE DEBTORS AND ALL HOLDERS OF CLAIMS AND INTERESTS; (D) FAIR, EQUITABLE, AND REASONABLE; (E) GIVEN AND MADE AFTER DUE NOTICE AND OPPORTUNITY FOR HEARING; AND (F) A BAR TO ANY OF THE DEBTORS, THE WIND DOWN DEBTORS, OR THE DEBTORS' ESTATES ASSERTING ANY CLAIM OR CAUSE OF ACTION RELEASED PURSUANT TO THE DEBTOR RELEASE.

"RELEASED PARTY" MEANS, COLLECTIVELY, AND IN EACH CASE IN THEIR RESPECTIVE CAPACITIES AS SUCH AND SUBJECT TO THE LIMITATIONS SET FORTH IN ARTICLE VIII.C HEREOF: (A) (I) THE DEBTORS AND THE WIND DOWN DEBTORS, (II) VIDA, (III) THE BONDHOLDER COMMITTEE AND EACH OF ITS MEMBERS, (IV) ANTHONY R. HORTON, IN HIS CAPACITIES AS AN INDEPENDENT DIRECTOR AND DIRECTOR OF THE DEBTORS, (V) JEFFREY S. STEIN, IN HIS CAPACITIES AS AN OFFICER, AN INDEPENDENT DIRECTOR, AND A DIRECTOR OF THE DEBTORS, (VI) MICHAEL A. TUCKER, IN HIS CAPACITY AS AN OFFICER OF THE DEBTORS, (VII) THE DLP INDEPENDENT DIRECTORS, (VIII) FTI CONSULTING, INC., (IX) PJT PARTNERS LP, AND (X) ANY OTHER PROFESSIONAL RETAINED BY THE DEBTORS, THE INDEPENDENT DIRECTORS, THE DLP INDEPENDENT DIRECTORS, OR THE BONDHOLDER COMMITTEE BY ORDER OF THE BANKRUPTCY COURT IN THE CHAPTER 11 CASES OR ANY PROFESSIONAL RETAINED BY ANY OF THE MEMBERS OF THE BONDHOLDER COMMITTEE, EACH IN SUCH CAPACITY; AND (B) SOLELY TO THE EXTENT AND ON THE TERMS AND CONDITIONS SET FORTH IN THIS PLAN, THE LBM RELEASED PARTIES.

“NON-RELEASED PARTIES” SHALL MEAN ANY ENTITIES THAT ARE NOT RELEASED PARTIES, WHICH ENTITIES SHALL INCLUDE, WITHOUT LIMITATION, BENEFICIENT, ITS CURRENT AND FORMER DIRECTORS AND OFFICERS (INCLUDING, WITHOUT LIMITATION, BRADLEY K. HEPPNER, THOMAS O. HICKS, BRUCE W. SCHNITZER, DENNIS P. LOCKHART, AND PETER T. CANGANY), HCLP NOMINEES, L.L.C., THE DEBTORS’ FORMER DIRECTORS AND OFFICERS (INCLUDING, WITHOUT LIMITATION, MURRAY HOLLAND AND TIMOTHY EVANS) IN THEIR CAPACITY OR CAPACITIES AS SUCH, AND ANY ENTITIES AFFILIATED WITH OR OTHERWISE RELATED TO THE FOREGOING.

Article VIII.E of the Plan provides for an exculpation of certain parties (the “**Exculpation**”):

EXCEPT AS OTHERWISE EXPRESSLY STATED IN THIS PLAN OR THE CONFIRMATION ORDER, AS OF THE EFFECTIVE DATE, EACH EXCULPATED PARTY SHALL BE DEEMED TO BE RELEASED AND EXCULPATED FROM ANY CLAIM, OBLIGATION, CAUSE OF ACTION, OR LIABILITY FOR ANY EXCULPATED CLAIM, EXCEPT FOR CLAIMS RELATED TO ANY ACT OR OMISSION THAT IS DETERMINED IN A FINAL ORDER TO HAVE CONSTITUTED INTENTIONAL BREACH OF FIDUCIARY DUTY, ACTUAL FRAUD, WILLFUL MISCONDUCT, OR GROSS NEGLIGENCE, BUT IN ALL RESPECTS EACH DEBTOR AND EACH EXCULPATED PARTY SHALL BE ENTITLED TO REASONABLY RELY UPON THE ADVICE OF COUNSEL WITH RESPECT TO THEIR DUTIES AND RESPONSIBILITIES PURSUANT TO THE PLAN. THE EXCULPATED PARTIES HAVE, AND UPON THE CONSUMMATION OF THE PLAN, SHALL BE DEEMED TO HAVE, PARTICIPATED IN GOOD FAITH AND IN COMPLIANCE WITH APPLICABLE LAW WITH REGARD TO THE RESTRUCTURING OF CLAIMS AND INTERESTS IN THE CHAPTER 11 CASES AND IN CONNECTION WITH THE WIND DOWN TRANSACTIONS, THE NEGOTIATION, FORMULATION, OR PREPARATION OF THE WIND DOWN DOCUMENTS OR RELATED AGREEMENTS, INSTRUMENTS, OR OTHER DOCUMENTS (INCLUDING, FOR THE AVOIDANCE OF DOUBT, PROVIDING ANY LEGAL OPINION REQUESTED BY ANY ENTITY REGARDING ANY TRANSACTION, CONTRACT, INSTRUMENT, DOCUMENT, OR OTHER AGREEMENT CONTEMPLATED BY THE PLAN OR THE RELIANCE BY ANY RELEASED PARTY ON THE PLAN OR THE CONFIRMATION ORDER IN LIEU OF SUCH LEGAL OPINION) IN CONNECTION WITH THE PLAN, AND THE SOLICITATION OF THE PLAN AND DISTRIBUTIONS PURSUANT TO THE PLAN AND, THEREFORE, ARE NOT, AND ON ACCOUNT OF SUCH DISTRIBUTIONS SHALL NOT BE, LIABLE AT ANY TIME FOR THE VIOLATION OF ANY APPLICABLE LAW, RULE, OR REGULATION GOVERNING THE SOLICITATION OF ACCEPTANCES OR REJECTIONS OF THE PLAN OR SUCH DISTRIBUTIONS MADE PURSUANT TO THE PLAN, EXCEPT FOR CLAIMS RELATED TO ANY ACT OR OMISSION THAT IS DETERMINED IN A FINAL ORDER TO HAVE CONSTITUTED INTENTIONAL BREACH OF FIDUCIARY DUTY, ACTUAL FRAUD, WILLFUL MISCONDUCT, OR GROSS NEGLIGENCE. THE DEBTORS AND THE CREDITOR PROPONENTS AGREE THAT (1) NEITHER THE ACT ITSELF OF FILING OR PROSECUTING A MOTION TO APPROVE A SETTLEMENT OF ANY ESTATE CAUSES OF ACTION WITH BENEFICIENT, ANY OF ITS AFFILIATES OR

RELATED PARTIES, AND/OR ANY OTHER NON-RELEASED PARTY NOR THE ACT ITSELF OF FILING OR PROSECUTING ANY OBJECTION TO ANY SUCH SETTLEMENT IN AND OF ITSELF CONSTITUTES AN INTENTIONAL BREACH OF FIDUCIARY DUTY, AND (2) ANY CLAIMS THAT THE DEBTORS OR THE CREDITOR PROPONENTS MAY SEEK TO BRING AGAINST ANY EXCULPATED PARTY SHALL BE LIMITED TO ANY ACTIONS OF SUCH EXCULPATED PARTY SOLELY AFTER THE DATE OF EXECUTION OF THE MEDIATION AGREEMENT; PROVIDED THAT ANY SUCH CLAIMS MUST BE FILED EXCLUSIVELY IN THE BANKRUPTCY COURT AND IN ACCORDANCE WITH THE FEDERAL RULES OF CIVIL PROCEDURES, AND SUCH CLAIMS SHALL BE PLED WITH SPECIFICITY WITH RESPECT TO THE WHO, WHAT, WHEN, WHERE, AND HOW OF THE ALLEGED WRONGFUL CONDUCT.

“EXCULPATED PARTY” MEANS, COLLECTIVELY, AND IN EACH CASE, IN THEIR RESPECTIVE CAPACITIES AS SUCH: (A) JEFFREY S. STEIN, IN HIS CAPACITIES AS AN OFFICER, AN INDEPENDENT DIRECTOR, AND A DIRECTOR OF THE DEBTORS; (B) ANTHONY R. HORTON, IN HIS CAPACITIES AS AN INDEPENDENT DIRECTOR AND DIRECTOR OF THE DEBTORS; (C) MICHAEL A. TUCKER, IN HIS CAPACITY AS AN OFFICER OF THE DEBTORS; (D) THE NON-MANAGEMENT DIRECTORS, IN THEIR CAPACITY AS SUCH; (E) THE DLP INDEPENDENT DIRECTORS, IN THEIR CAPACITY AS SUCH; (F) THE MEMBERS OF THE BONDHOLDER COMMITTEE, IN THEIR CAPACITY AS SUCH; (G) ANY PROFESSIONAL RETAINED BY THE DEBTORS, THE INDEPENDENT DIRECTORS, THE DLP INDEPENDENT DIRECTORS, THE BONDHOLDER COMMITTEE, IN SUCH PROFESSIONALS’ CAPACITY AS SUCH; AND (H) ANY PROFESSIONAL RETAINED BY ANY OF THE MEMBERS OF THE BONDHOLDER COMMITTEE, EACH IN SUCH PROFESSIONALS’ CAPACITY AS SUCH.

“EXCULPATED CLAIM” MEANS ANY CLAIM RELATED TO ANY ACT OR OMISSION FROM THE PETITION DATE TO THE EFFECTIVE DATE IN CONNECTION WITH, RELATING TO, OR ARISING OUT OF: (A) THE CHAPTER 11 CASES; (B) THE FORMULATION, PREPARATION, DISSEMINATION, OR NEGOTIATION OF ANY DOCUMENT IN CONNECTION WITH THE CHAPTER 11 CASES; (C) ANY CONTRACT, INSTRUMENT, RELEASE, AND/OR OTHER AGREEMENT OR DOCUMENT CREATED OR ENTERED INTO IN CONNECTION WITH THE CHAPTER 11 CASES; (D) THE PURSUIT OF CONSUMMATION; AND/OR (E) THE FILING, ADMINISTRATION, AND/OR IMPLEMENTATION OF THE CHAPTER 11 CASES, OR THE DISTRIBUTION OF PROPERTY IN CONNECTION THEREWITH OR THEREUNDER; PROVIDED, THAT, FOR THE AVOIDANCE OF DOUBT, ANY PREPETITION ADVICE PROVIDED BY ANY LEGAL PROFESSIONALS IN CONNECTION WITH PREPETITION TRANSACTIONS BETWEEN THE DEBTORS AND BENEFICIENT SHALL NOT CONSTITUTE ANY ACT OR OMISSION THAT IS COVERED BY THIS DEFINITION OF EXCULPATED CLAIM; PROVIDED, FURTHER, THAT, NOTWITHSTANDING THE FOREGOING, EXCULPATED CLAIMS SHALL NOT INCLUDE ANYTHING RELATED TO ANY ACT OR OMISSION THAT IS DETERMINED IN A FINAL ORDER TO HAVE

CONSTITUTED ACTUAL FRAUD, WILLFUL MISCONDUCT, INTENTIONAL BREACH OF FIDUCIARY DUTY, OR GROSS NEGLIGENCE.

Article VIII.G of the Plan establishes an injunction (the “**Injunction**”):

EXCEPT AS OTHERWISE EXPRESSLY PROVIDED IN THE PLAN OR THE CONFIRMATION ORDER OR FOR OBLIGATIONS OR DISTRIBUTIONS REQUIRED TO BE PAID PURSUANT TO THE PLAN OR THE CONFIRMATION ORDER, ALL ENTITIES WHO HAVE HELD, HOLD, OR MAY HOLD CLAIMS THAT HAVE BEEN RELEASED PURSUANT TO ARTICLE VIII HEREOF ARE PERMANENTLY ENJOINED, FROM AND AFTER THE EFFECTIVE DATE, FROM TAKING ANY OF THE FOLLOWING ACTIONS AGAINST, AS APPLICABLE, THE DEBTORS, THE RELEASED PARTIES, OR THE EXCULPATED PARTIES: (1) COMMENCING OR CONTINUING IN ANY MANNER ANY ACTION OR OTHER PROCEEDING OF ANY KIND ON ACCOUNT OF OR IN CONNECTION WITH OR WITH RESPECT TO ANY OF THE CLAIMS OR INTERESTS RELEASED HEREUNDER; (2) ENFORCING, ATTACHING, COLLECTING, OR RECOVERING BY ANY MANNER OR MEANS ANY JUDGMENT, AWARD, DECREE, OR ORDER AGAINST SUCH ENTITIES ON ACCOUNT OR IN CONNECTION WITH OR WITH RESPECT TO ANY CLAIMS OR INTERESTS RELEASED HEREUNDER; (3) CREATING, PERFECTING, OR ENFORCING ANY LIEN OR ENCUMBRANCE OF ANY KIND AGAINST SUCH ENTITIES OR THE PROPERTY OF SUCH ENTITIES ON ACCOUNT OR IN CONNECTION WITH OR WITH RESPECT TO ANY CLAIMS OR INTERESTS RELEASED HEREUNDER; (4) ASSERTING ANY RIGHT OF SETOFF, SUBROGATION, OR RECOUPMENT OF ANY KIND AGAINST ANY OBLIGATION DUE FROM SUCH ENTITIES OR AGAINST THE PROPERTY OR THE ESTATES OF SUCH ENTITIES ON ACCOUNT OR IN CONNECTION WITH OR WITH RESPECT TO ANY CLAIMS OR INTERESTS RELEASED HEREUNDER, UNLESS SUCH HOLDER HAS FILED A MOTION REQUESTING THE RIGHT TO PERFORM SUCH SETOFF ON OR BEFORE THE EFFECTIVE DATE, AND NOTWITHSTANDING AN INDICATION OF A CLAIM OR INTEREST OR OTHERWISE THAT SUCH HOLDER ASSERTS, HAS, OR INTENDS TO PRESERVE ANY RIGHT OF SETOFF PURSUANT TO APPLICABLE LAW OR OTHERWISE; AND (5) COMMENCING OR CONTINUING IN ANY MANNER ANY ACTION OR OTHER PROCEEDING OF ANY KIND ON ACCOUNT OF OR IN CONNECTION WITH OR WITH RESPECT TO ANY CLAIMS OR INTERESTS RELEASED OR SETTLED PURSUANT TO THIS PLAN.

UPON ENTRY OF THE CONFIRMATION ORDER, ALL HOLDERS OF CLAIMS AND INTERESTS AND THEIR RESPECTIVE CURRENT AND FORMER EMPLOYEES, AGENTS, OFFICERS, DIRECTORS, PRINCIPALS, AND DIRECT AND INDIRECT AFFILIATES SHALL BE ENJOINED FROM TAKING ANY ACTIONS TO INTERFERE WITH THE IMPLEMENTATION OR CONSUMMATION OF THIS PLAN. EXCEPT AS OTHERWISE SET FORTH IN THE CONFIRMATION ORDER, EACH HOLDER OF AN ALLOWED CLAIM OR ALLOWED INTEREST, AS APPLICABLE, BY ACCEPTING, OR BEING ELIGIBLE TO ACCEPT, DISTRIBUTIONS UNDER THIS PLAN SHALL BE DEEMED TO HAVE CONSENTED TO THE INJUNCTION PROVISIONS SET FORTH HEREIN.

Item 5. Certifications.

By signing this Ballot, the undersigned certifies to the Court and the Debtors that:

- (a) as of the Voting Record Date, either: (i) the Entity is the Holder of the Claims being voted; or (ii) the Entity is an authorized signatory, with full power and authority to vote to accept or reject the Plan with respect to the Claims identified in Item 1 above, for an Entity that is a Holder of the Claims being voted;
- (b) the Entity (or in the case of an authorized signatory, the Holder) has received the Solicitation Package and acknowledges that the solicitation is being made pursuant to the terms and conditions set forth therein;
- (d) the Entity has cast the same vote with respect to all of its Claims in the above-referenced Class; and
- (e) no other Ballots with respect to the amount of the Claims identified in Item 2 have been cast or, if any other Ballots have been cast with respect to such Claims or Interests, then any such earlier Ballots are hereby revoked.

Name of Holder: _____ (Print or Type)
Signature: _____
Name of Signatory: _____ (If other than Holder)
Title: _____
Address: _____ _____ _____
Telephone Number: _____
Email: _____
Date Completed: _____

IF THE SOLICITATION AGENT DOES NOT ACTUALLY RECEIVE THIS BALLOT ON OR BEFORE MAY 31, 2023 AT 4:00 P.M. PREVAILING CENTRAL TIME, AND IF THE VOTING DEADLINE IS NOT EXTENDED, YOUR VOTE TRANSMITTED BY THIS BALLOT MAY BE COUNTED TOWARD CONFIRMATION OF THE PLAN ONLY IN THE DISCRETION OF THE DEBTORS.

INSTRUCTIONS FOR COMPLETING THIS BALLOT

1. The Debtors are soliciting the votes of Holders of Claims with respect to the Plan. **PLEASE READ THE PLAN AND THE DISCLOSURE STATEMENT CAREFULLY BEFORE COMPLETING THIS BALLOT.**
2. The Plan can be confirmed by the Court and thereby made binding upon you if it is accepted by the Holders of at least two-thirds in total dollar amount and more than one-half in number of Claims that actually vote on the Plan and if the Plan otherwise satisfies the requirements for confirmation provided by section 1129(a) of the Bankruptcy Code. Please review the Disclosure Statement for more information.
3. To ensure that your Ballot is counted, you *must* complete and submit this Ballot as instructed herein. **Ballots will not be accepted by facsimile.**
4. **Use of Ballot.** To ensure that your Ballot is counted, you must: (a) complete your Ballot in accordance with these instructions; (b) clearly indicate your decision either to accept or reject the Plan in the boxes provided in Item 2 of the Ballot; and (c) clearly sign and submit your Ballot as instructed herein.
5. Your completed Ballot *must* be returned to the *Solicitation Agent* so as to be *actually received* by the Solicitation Agent on or before the Voting Deadline. **Do not** send Ballots to the Debtors, Indenture Trustee, Bondholder Committee, any advisors to the foregoing, the Court. **The Voting Deadline is May 31, 2023 at 4:00 p.m. (prevailing Central Time).**
6. If a Ballot is received after the Voting Deadline and if the Voting Deadline is not extended, it may not be counted. Additionally, the following Ballots will not be counted:
 - (a) any Ballot that partially rejects and partially accepts the Plan;
 - (b) Ballots sent to the Debtors, the Debtors' agents (other than the Solicitation Agent), any agent, indenture trustee, or the Debtors' financial or legal advisors;
 - (c) Ballots sent by facsimile or other unapproved means;
 - (d) any Ballot that is illegible or contains insufficient information to permit the identification of the Holder of the Claim;
 - (e) any Ballot cast by an Entity that does not hold a Claim entitled to vote pursuant to the Plan or Solicitation Procedures;
 - (f) any Ballot submitted by a Holder not entitled to vote pursuant to the Plan or Solicitation Procedures;
 - (g) any unsigned Ballot (for the avoidance of doubt, Ballots validly submitted through the E-Ballot Portal or via email will be deemed signed); and/or

- (h) any Ballot not marked to accept or reject the Plan or any Ballot marked both to accept and reject the Plan.
- 7. The method of delivery of Ballots to the Solicitation Agent is at the election and risk of each Holder of a Claim or Interest. Except as otherwise provided herein, such delivery will be deemed made only when the Solicitation Agent **actually receives** the originally executed Ballot. In all cases, Holders should allow sufficient time to assure timely delivery.
- 8. If multiple Ballots are received from the same Holder of a Claim or Interest with respect to the same Claim or Interest prior to the Voting Deadline, the latest, timely received, and properly completed Ballot will supersede and revoke any earlier received Ballots.
- 9. You must vote all of your Claims or Interests in the above-referenced class, regardless if such Claims or Interests are asserted against one or multiple Debtors, either to accept or reject the Plan and may *not* split your vote.
- 10. This Ballot does *not* constitute, and shall not be deemed to be, (a) a Proof of Claim or Proof of Interest or (b) an assertion or admission of a Claim or Interest.
- 11. **Please be sure to sign and date your Ballot.** If you are signing a Ballot in your capacity as a trustee, executor, administrator, guardian, attorney in fact, officer of a corporation, or otherwise acting in a fiduciary or representative capacity, you must indicate such capacity when signing and, if required or requested by the Solicitation Agent, the Debtors, or the Court, must submit proper evidence to the requesting party to so act on behalf of such Holder. In addition, please provide your name and mailing address if it is different from that set forth on the attached mailing label or if no such mailing label is attached to the ballot.

PLEASE SUBMIT YOUR BALLOT PROMPTLY

IF YOU HAVE ANY QUESTIONS REGARDING THIS BALLOT, THESE VOTING INSTRUCTIONS, OR THE PROCEDURES FOR VOTING, PLEASE CALL THE SOLICITATION AGENT AT:

U.S. TOLL FREE: (888) 508-2507

OR EMAIL GWGINFO@DONLINRECANO.COM

IF THE SOLICITATION AGENT DOES NOT ACTUALLY RECEIVE THIS BALLOT ON OR BEFORE THE VOTING DEADLINE, WHICH IS ON MAY 31, 2023 AT 4:00 P.M., PREVAILING CENTRAL TIME, AND IF THE VOTING DEADLINE IS NOT EXTENDED, YOUR VOTE TRANSMITTED HEREBY MAY BE COUNTED ONLY IN THE DISCRETION OF THE DEBTORS.

Exhibit 4A

Unimpaired Non-Voting Status Notice

**IN THE UNITED STATES BANKRUPTCY COURT
FOR THE SOUTHERN DISTRICT OF TEXAS
HOUSTON DIVISION**

In re:)	
)	Chapter 11
GWG Holdings, Inc., <i>et al.</i> , ¹)	Case No. 22-90032 (MI)
Debtors.)	(Jointly Administered)

**NOTICE OF NON-VOTING STATUS TO HOLDERS OF UNCLASSIFIED CLAIMS
AND UNIMPAIRED CLAIMS CONCLUSIVELY PRESUMED TO ACCEPT THE PLAN**

PLEASE TAKE NOTICE THAT on April 21, 2023, the United States Bankruptcy Court for the Southern District of Texas (the “Court”) entered an order [Docket No. 1681²] (the “Disclosure Statement Order”): (a) authorizing the above-captioned debtors and debtors in possession (collectively, the “Debtors”) to solicit votes on the *Debtors’ Second Amended Joint Chapter 11 Plan* [Docket No. 1678] (as may be amended, supplemented, or modified from time to time and including all exhibits and supplements thereto, the “Plan”);³ (b) approving the *Disclosure Statement for the Debtors’ Second Amended Joint Chapter 11 Plan* [Docket No. 1682] (the “Disclosure Statement”) as containing “adequate information” pursuant to section 1125 of the Bankruptcy Code; (c) approving the solicitation documents to be included in the solicitation packages; (d) approving procedures for soliciting, receiving, and tabulating votes on the Plan and for filing objections to the Plan; and (e) scheduling certain dates with respect thereto.

PLEASE TAKE FURTHER NOTICE THAT because of the nature and treatment of your Claim under the Plan, *you are not entitled to vote on the Plan*. Specifically, under the terms of the Plan, as a Holder of a Claim (as currently asserted against the Debtors) that is (a) Unimpaired and conclusively presumed to have accepted the Plan pursuant to section 1126(f) of the Bankruptcy Code or (b) unclassified, you are *not* entitled to vote on the Plan.

PLEASE TAKE FURTHER NOTICE THAT the hearing to consider confirmation of the Plan (the “Confirmation Hearing”) will commence on **June 15, 2023 at 1:30 p.m. (prevailing Central Time)**, before the Honorable Marvin Isgur, in the United States Bankruptcy Court for the Southern District of Texas, located at 515 Rusk Street, Courtroom 404, Houston, Texas, 77002. Please be advised that the Confirmation Hearing may be continued from time to time by the Court

¹ The Debtors in these chapter 11 cases, along with the last four digits of each Debtor’s federal tax identification number, are: GWG Holdings, Inc. (2607); GWG Life, LLC (6955); GWG Life USA, LLC (5538) GWG DLP Funding IV, LLC (2598); GWG DLP Funding VI, LLC (6955) and GWG DLP Funding Holdings VI, LLC (6955). The location of Debtor GWG Holdings, Inc.’s principal place of business and the Debtors’ service address is 325 N. St. Paul Street, Suite 2650, Dallas, TX 75201. Further information regarding the Debtors and these chapter 11 cases is available at the website of the Debtors’ claims and noticing agent: <https://donlinrecano.com/gwg>.

² As modified pursuant to the order entered at docket 1692.

³ Capitalized terms used but not otherwise defined herein shall have the meanings ascribed to such terms in the Plan, Disclosure Statement, or the Disclosure Statement Order, as applicable.

or the Debtors without further notice other than by such adjournment being announced in open court or by a notice of adjournment filed with the Court and served on other parties entitled to notice.

PLEASE TAKE FURTHER NOTICE THAT the deadline for filing objections to confirmation of the Plan is **May 31, 2023 at 11:59 p.m. (prevailing Central Time)** (the “Confirmation Objection Deadline”). Objections to any relief sought at the Confirmation Hearing must (a) be in writing; (b) conform to the Bankruptcy Rules, the Bankruptcy Local Rules, and any orders of the Court; (c) state the name, address, phone number, and e-mail address of the objecting party and the amount and nature of the Claim or Interest of such entity, if any; (d) state, with particularity, the legal and factual basis for the objection and, if practicable, a proposed modification to the Plan (or related materials) that would resolve such objection; and (e) be filed with the Court on or before the Confirmation Objection Deadline. Objections that fail to comply with this Order will not be considered by the Court.

PLEASE TAKE FURTHER NOTICE THAT if you would like to obtain a copy of the Disclosure Statement Order, the Plan, the Disclosure Statement, the Solicitation Procedures, the Plan Supplement, or related documents, such materials are available free of charge by: (a) accessing the Debtors’ restructuring website at <https://www.donlinrecano.com/Clients/gwg/Index>; (b) writing to Donlin, Recano & Company, Inc., Re: GWG Holdings, Inc., et al., P.O. Box 199043, Blythebourne Station, Brooklyn, NY 11219; (c) calling 1 (888) 508-2507 (U.S. toll free); or (d) emailing gwginfo@donlinrecano.com. You may also obtain copies of any pleadings filed in the Chapter 11 Cases for a fee via PACER at <https://ecf.txsb.uscourts.gov/>.

ARTICLE VIII OF THE PLAN CONTAINS RELEASE, EXCULPATION, AND INJUNCTION PROVISIONS. YOU ARE ADVISED TO REVIEW AND CONSIDER THE PLAN CAREFULLY BECAUSE YOUR RIGHTS MIGHT BE AFFECTED THEREUNDER. THIS NOTICE IS BEING SENT TO YOU FOR INFORMATIONAL PURPOSES ONLY.

Houston, Texas
April ____, 2023

Respectfully Submitted,

JACKSON WALKER LLP

Kristhy M. Peguero (TX Bar No. 24102776)
Matthew D. Cavanaugh (TX Bar No. 24062656)
1401 McKinney Street, Suite 1900
Houston, TX 77010
Telephone: (713) 752-4200
Email: kpeguero@jw.com
mcaavanaugh@jw.com

Co-Counsel for the Debtors and Debtors in Possession

MAYER BROWN LLP

Charles S. Kelley (TX Bar No. 11199580)
700 Louisiana Street, Suite 3400
Houston, TX 77002-2730
Telephone: (713) 238-3000
Email: ckelley@mayerbrown.com

-and-

Thomas S. Kiriakos (admitted *pro hac vice*)
Louis S. Chiappetta (admitted *pro hac vice*)
71 S. Wacker Drive
Chicago, IL 60606
Telephone: (312) 701-0600
Email: tkiriakos@mayerbrown.com
lchiappetta@mayerbrown.com

-and-

Adam C. Paul (admitted *pro hac vice*)
Lucy F. Kweskin (admitted *pro hac vice*)
1221 Avenue of the Americas
New York, NY 10020-1001
Telephone: (212) 506-2500
Email: apaul@mayerbrown.com
lkweskin@mayerbrown.com

Counsel for the Debtors and Debtors in Possession

Exhibit 4B

Disputed Claims Non-Voting Status Notice

**IN THE UNITED STATES BANKRUPTCY COURT
FOR THE SOUTHERN DISTRICT OF TEXAS
HOUSTON DIVISION**

In re:)	
)	Chapter 11
GWG Holdings, Inc., <i>et al.</i> , ¹)	
)	Case No. 22-90032 (MI)
Debtors.)	
)	(Jointly Administered)

**NOTICE OF NON-VOTING STATUS
TO HOLDERS OF DISPUTED CLAIMS OR INTERESTS**

PLEASE TAKE NOTICE THAT on April 21, 2023, the United States Bankruptcy Court for the Southern District of Texas (the “Court”) entered an order [Docket No. 1681²] (the “Disclosure Statement Order”): (a) authorizing the above-captioned debtors and debtors in possession (collectively, the “Debtors”) to solicit votes on the *Debtors’ Second Amended Joint Chapter 11 Plan* [Docket No. 1678] (as may be amended, supplemented, or modified from time to time and including all exhibits and supplements thereto, the “Plan”);³ (b) approving the *Disclosure Statement for the Debtors’ Second Amended Joint Chapter 11 Plan* [Docket No. 1682] (the “Disclosure Statement”) as containing “adequate information” pursuant to section 1125 of the Bankruptcy Code; (c) approving the solicitation documents to be included in the solicitation packages; (d) approving procedures for soliciting, receiving, and tabulating votes on the Plan and for filing objections to the Plan; and (e) scheduling certain dates with respect thereto.

PLEASE TAKE FURTHER NOTICE THAT you are receiving this notice because you are the Holder of a Claim or Interest that is subject to a pending objection by the Debtors. **You are not entitled to vote any disputed portion of your Claim on the Plan unless one or more of the following events have taken place prior to the Voting Deadline** (each, a “Resolution Event”):

1. an order of the Court is entered allowing such Claim or Interest pursuant to section 502(b) of the Bankruptcy Code, after notice and a hearing;

¹ The Debtors in these chapter 11 cases, along with the last four digits of each Debtor’s federal tax identification number, are: GWG Holdings, Inc. (2607); GWG Life, LLC (6955); GWG Life USA, LLC (5538) GWG DLP Funding IV, LLC (2598); GWG DLP Funding VI, LLC (6955) and GWG DLP Funding Holdings VI, LLC (6955). The location of Debtor GWG Holdings, Inc.’s principal place of business and the Debtors’ service address is 325 N. St. Paul Street, Suite 2650, Dallas, TX 75201. Further information regarding the Debtors and these chapter 11 cases is available at the website of the Debtors’ claims and noticing agent: <https://donlinrecano.com/gwg>.

² As modified pursuant to the order entered at docket 1692.

³ Capitalized terms used but not otherwise defined herein shall have the meanings ascribed to such terms in the Plan, Disclosure Statement, or the Disclosure Statement Order, as applicable.

2. an order of the Court is entered temporarily allowing such Claim or Interest for voting purposes only pursuant to Bankruptcy Rule 3018(a), after notice and a hearing;
3. a stipulation or other agreement is executed between you and the Debtors temporarily allowing the Holder of such Claim or Interest to vote its Claim or Interest in an agreed upon amount; or
4. the pending objection to such Claim or Interest, if any, is voluntarily withdrawn by the objecting party.

PLEASE TAKE FURTHER NOTICE THAT the hearing to consider confirmation of the Plan (the “Confirmation Hearing”) will commence on **June 15, 2023 at 1:30 p.m. (prevailing Central Time)**, before the Honorable Marvin Isgur, in the United States Bankruptcy Court for the Southern District of Texas, located at 515 Rusk Street, Courtroom 404, Houston, Texas, 77002. Please be advised that the Confirmation Hearing may be continued from time to time by the Court or the Debtors without further notice other than by such adjournment being announced in open court or by a notice of adjournment filed with the Court and served on other parties entitled to notice.

PLEASE TAKE FURTHER NOTICE THAT the deadline for filing objections to confirmation of the Plan is **May 31, 2023 at 11:59 p.m. (prevailing Central Time)** (the “Confirmation Objection Deadline”). Objections to any relief sought at the Confirmation Hearing must (a) be in writing; (b) conform to the Bankruptcy Rules, the Bankruptcy Local Rules, and any orders of the Court; (c) state the name, address, phone number, and e-mail address of the objecting party and the amount and nature of the Claim or Interest of such entity, if any; (d) state, with particularity, the legal and factual basis for the objection and, if practicable, a proposed modification to the Plan (or related materials) that would resolve such objection; and (e) be filed with the Court (contemporaneously with a proof of service) upon the applicable notice parties so to be actually received on or before the Confirmation Objection Deadline. Objections that fail to comply with this Order will not be considered by the Court.

PLEASE TAKE FURTHER NOTICE THAT if you would like to obtain a copy of the Disclosure Statement Order, the Plan, the Disclosure Statement, the Solicitation Procedures, the Plan Supplement, or related documents, such materials are available free of charge by: (a) accessing the Debtors’ restructuring website at <https://www.donlinrecano.com/Clients/gwg/Index>; (b) writing to Donlin, Recano & Company, Inc., Re: GWG Holdings, Inc., et al., P.O. Box 199043, Blythebourne Station, Brooklyn, NY 11219; (c) calling 1 (888) 508-2507 (U.S. toll free); or (d) emailing gwginfo@donlinrecano.com. You may also obtain copies of any pleadings filed in the Chapter 11 Cases for a fee via PACER at <https://ecf.txsb.uscourts.gov/>.

ARTICLE VIII OF THE PLAN CONTAINS RELEASE, EXCULPATION, AND INJUNCTION PROVISIONS. YOU ARE ADVISED TO REVIEW AND CONSIDER THE PLAN CAREFULLY BECAUSE YOUR RIGHTS MIGHT BE AFFECTED THEREUNDER. THIS NOTICE IS BEING SENT TO YOU FOR INFORMATIONAL PURPOSES ONLY.

Houston, Texas
April __, 2023

Respectfully Submitted,

JACKSON WALKER LLP

Kristhy M. Peguero (TX Bar No. 24102776)
Matthew D. Cavanaugh (TX Bar No. 24062656)
1401 McKinney Street, Suite 1900
Houston, TX 77010
Telephone: (713) 752-4200
Email: kpeguero@jw.com
mcaavanaugh@jw.com

Co-Counsel for the Debtors and Debtors in Possession

MAYER BROWN LLP

Charles S. Kelley (TX Bar No. 11199580)
700 Louisiana Street, Suite 3400
Houston, TX 77002-2730
Telephone: (713) 238-3000
Email: ckelley@mayerbrown.com

-and-

Thomas S. Kiriakos (admitted *pro hac vice*)
Louis S. Chiappetta (admitted *pro hac vice*)
71 S. Wacker Drive
Chicago, IL 60606
Telephone: (312) 701-0600
Email: tkiriakos@mayerbrown.com
lchiappetta@mayerbrown.com

-and-

Adam C. Paul (admitted *pro hac vice*)
Lucy F. Kweskin (admitted *pro hac vice*)
1221 Avenue of the Americas
New York, NY 10020-1001
Telephone: (212) 506-2500
Email: apaul@mayerbrown.com
lkweskin@mayerbrown.com

Counsel for the Debtors and Debtors in Possession

Exhibit 5

Assumption Notice

**IN THE UNITED STATES BANKRUPTCY COURT
FOR THE SOUTHERN DISTRICT OF TEXAS
HOUSTON DIVISION**

In re:)	
)	Chapter 11
GWG Holdings, Inc., <i>et al.</i> , ¹)	
)	Case No. 22-90032 (MI)
Debtors.)	
)	(Jointly Administered)

NOTICE OF (I) EXECUTORY CONTRACTS AND UNEXPIRED LEASES TO BE ASSUMED BY THE DEBTORS PURSUANT TO THE PLAN, (II) CURE AMOUNTS, IF ANY, AND (III) RELATED PROCEDURES IN CONNECTION THEREWITH

PLEASE TAKE NOTICE THAT on April 21, 2023, the United States Bankruptcy Court for the Southern District of Texas (the “Court”) entered an order [Docket No. 1681²] (the “Disclosure Statement Order”): (a) authorizing the above-captioned debtors and debtors in possession (collectively, the “Debtors”) to solicit votes on the *Debtors’ Second Amended Joint Chapter 11 Plan* [Docket No. 1678] (as may be amended, supplemented, or modified from time to time and including all exhibits and supplements thereto, the “Plan”);³ (b) approving the *Disclosure Statement for the Debtors’ Second Amended Joint Chapter 11 Plan* [Docket No. 1682] (the “Disclosure Statement”) as containing “adequate information” pursuant to section 1125 of the Bankruptcy Code; (c) approving the solicitation documents to be included in the solicitation packages; (d) approving procedures for soliciting, receiving, and tabulating votes on the Plan and for filing objections to the Plan; and (e) scheduling certain dates with respect thereto.

PLEASE TAKE FURTHER NOTICE THAT the Debtors filed the *Schedule of Assumed Executory Contracts and Unexpired Leases* [Docket No. [●]] (the “Assumption Schedule”) with the Court as part of the Plan Supplement on [●], as contemplated under the Plan, a copy of which is attached hereto as **Schedule A**. The Assumption Schedule lists Executory Contracts and Unexpired Leases that the Debtors are proposing to assume and assign to the Reorganized Debtors under the Plan, and cure amounts related thereto. The Debtors’ determination to assume the agreements identified on the Assumption Schedule is subject to revision.⁴

¹ The Debtors in these chapter 11 cases, along with the last four digits of each Debtor’s federal tax identification number, are: GWG Holdings, Inc. (2607); GWG Life, LLC (6955); GWG Life USA, LLC (5538) GWG DLP Funding IV, LLC (2598); GWG DLP Funding VI, LLC (6955) and GWG DLP Funding Holdings VI, LLC (6955). The location of Debtor GWG Holdings, Inc.’s principal place of business and the Debtors’ service address is 325 N. St. Paul Street, Suite 2650, Dallas, TX 75201. Further information regarding the Debtors and these chapter 11 cases is available at the website of the Debtors’ claims and noticing agent: <https://donlinrecano.com/gwg>.

² As modified pursuant to the order entered at docket 1692.

³ Capitalized terms used but not otherwise defined herein shall have the meanings ascribed to such terms in the Plan, Disclosure Statement, or the Disclosure Statement Order, as applicable.

⁴ Neither the exclusion nor inclusion of any Executory Contract or Unexpired Lease on the Assumption Schedule, nor anything contained in the Plan or each Debtor’s schedule of assets and liabilities, shall constitute an admission

PLEASE TAKE FURTHER NOTICE THAT the hearing to consider confirmation of the Plan (the “Confirmation Hearing”) will commence on **June 15, 2023 at 1:30 p.m. (prevailing Central Time)**, before the Honorable Marvin Isgur, in the United States Bankruptcy Court for the Southern District of Texas, located at 515 Rusk Street, Courtroom 404, Houston, Texas, 77002. Please be advised that the Confirmation Hearing may be continued from time to time by the Court or the Debtors without further notice other than by such adjournment being announced in open court or by a notice of adjournment filed with the Court and served on other parties entitled to notice.

You may participate in the hearing either in person or by an audio and video connection. Audio communication will be by use of the Court’s dial-in facility. You may access the facility at (832) 917-1510. Once connected, you will be asked to enter the conference room number. Judge Isgur’s conference room number is 954554. Video communication will be by use of the GoToMeeting platform. Connect via the free GoToMeeting application or click the link on Judge Isgur’s home page. The meeting code is “JudgeIsgur”. Click the settings icon in the upper right corner and enter your name under the personal information setting. Hearing appearances must be made electronically in advance of both electronic and in-person hearings. To make your appearance, click the “Electronic Appearance” link on Judge Isgur’s home page. Select the case name, complete the required fields and click “Submit” to complete your appearance.

PLEASE TAKE FURTHER NOTICE THAT YOU ARE RECEIVING THIS NOTICE BECAUSE THE DEBTORS’ RECORDS REFLECT THAT YOU ARE A PARTY TO AN EXECUTORY CONTRACT OR UNEXPIRED LEASE THAT IS LISTED ON THE ASSUMPTION SCHEDULE. THEREFORE, YOU ARE ADVISED TO REVIEW CAREFULLY THE INFORMATION CONTAINED IN THIS NOTICE, THE ASSUMPTION SCHEDULE, AND THE RELATED PROVISIONS OF THE PLAN.

PLEASE TAKE FURTHER NOTICE THAT section 365(b)(1) of the Bankruptcy Code requires a chapter 11 debtor to cure, or provide adequate assurance that it will promptly cure, any defaults under executory contracts and unexpired leases at the time of assumption. Accordingly, the Debtors have conducted a thorough review of their books and records and have determined the amounts required to cure defaults, if any, under the Executory Contract(s) and Unexpired Lease(s), which amounts are listed in the Assumption Schedule. Please note that if no amount is stated for a particular Executory Contract or Unexpired Lease, the Debtors believe that there is no cure amount outstanding for such contract or lease.

PLEASE TAKE FURTHER NOTICE THAT absent any pending dispute, the monetary amounts required to cure any existing defaults arising under the Executory Contract(s) and Unexpired Lease(s) identified on the Assumption Schedule will be satisfied, pursuant to section 365(b)(1) of the Bankruptcy Code, by the Debtors in Cash on the Effective Date or as soon as

by the Debtors that any such contract or lease is in fact an Executory Contract or Unexpired Lease capable of assumption, that any Entity created or reorganized pursuant to the Plan has any liability thereunder, or that such Executory Contract or Unexpired Lease is necessarily a binding and enforceable agreement. Further, the Debtors expressly reserve the right to: (a) remove any Executory Contract or Unexpired Lease from the Assumption Schedule and reject such Executory Contract or Unexpired Lease pursuant to the terms of the Plan, up until and including 45 days after the Effective Date; and (b) contest any Claim (or cure amount) asserted in connection with assumption of any Executory Contract or Unexpired Lease.

reasonably practicable thereafter. In the event of a dispute, however, payment of the cure amount would be made following the entry of a final order(s) resolving the dispute and approving the assumption. If an objection to the proposed assumption or related cure amount is sustained by the Court, however, the Debtors may elect to reject such Executory Contract or Unexpired Lease in lieu of assuming it.

PLEASE TAKE FURTHER NOTICE THAT the deadline for filing objections to the assumption or Cure Amounts relating to Executory Contracts and Unexpired Leases is **30 calendar days after the date hereof at 11:59 p.m. (prevailing Central Time)** (the “Assumption Objection Deadline”). Any such objection must: (a) be in writing; (b) conform to the Bankruptcy Rules, the Bankruptcy Local Rules, and any orders of the Court; (c) state the name, address, phone number, and e-mail address of the objecting party and details concerning the Executory Contract or Unexpired Lease at issue; (d) state, with particularity, the legal and factual basis for the objection; and (e) be filed with the Court (contemporaneously with a proof of service) upon the applicable notice parties so to be actually received on or before the Assumption Objection Deadline.

PLEASE TAKE FURTHER NOTICE THAT any objections to the Plan in connection with the assumption of the Executory Contract(s) and Unexpired Lease(s) proposed in connection with the Plan that remain unresolved as of the Confirmation Hearing will be heard at a later date as fixed by the Court.

PLEASE TAKE FURTHER NOTICE THAT ANY COUNTERPARTY TO AN EXECUTORY CONTRACT OR UNEXPIRED LEASE THAT FAILS TO OBJECT TIMELY TO THE PROPOSED ASSUMPTION AND ASSIGNMENT OR CURE AMOUNT WILL BE DEEMED TO HAVE ASSENTED TO SUCH ASSUMPTION AND ASSIGNMENT AND CURE AMOUNT.

PLEASE TAKE FURTHER NOTICE THAT ASSUMPTION OF ANY EXECUTORY CONTRACT OR UNEXPIRED LEASE PURSUANT TO THE PLAN OR OTHERWISE SHALL RESULT IN THE FULL RELEASE AND SATISFACTION OF ANY CLAIMS OR DEFAULTS, WHETHER MONETARY OR NONMONETARY, INCLUDING DEFAULTS OF PROVISIONS RESTRICTING THE CHANGE IN CONTROL OR OWNERSHIP INTEREST COMPOSITION OR OTHER BANKRUPTCY-RELATED DEFAULTS, ARISING UNDER ANY ASSUMED EXECUTORY CONTRACT OR UNEXPIRED LEASE AT ANY TIME BEFORE THE DATE THE DEBTORS ASSUME SUCH EXECUTORY CONTRACT OR UNEXPIRED LEASE. ANY PROOFS OF CLAIM FILED WITH RESPECT TO AN EXECUTORY CONTRACT OR UNEXPIRED LEASE THAT HAS BEEN ASSUMED SHALL BE DEEMED DISALLOWED AND EXPUNGED, WITHOUT FURTHER NOTICE TO OR ACTION, ORDER, OR APPROVAL OF THE COURT.

PLEASE TAKE FURTHER NOTICE THAT if you would like to obtain a copy of the Disclosure Statement Order, the Plan, the Disclosure Statement, the Solicitation Procedures, the Plan Supplement, or related documents, such materials are available free of charge by: (a) accessing the Debtors’ restructuring website at <https://www.donlinrecano.com/Clients/gwg/Index>; (b) writing to Donlin, Recano & Company, Inc., Re: GWG Holdings, Inc., et al., P.O. Box 199043, Blythebourne Station, Brooklyn, NY 11219; (c) calling 1 (888) 508-2507 (U.S. toll free); or (d)

emailing gwginfo@donlinrecano.com. You may also obtain copies of any pleadings filed in the Chapter 11 Cases for a fee via PACER at <https://ecf.txs.uscourts.gov/>.

Houston, Texas
_____, 2023

Respectfully Submitted,

JACKSON WALKER LLP

Kristhy M. Peguero (TX Bar No. 24102776)
Matthew D. Cavanaugh (TX Bar No. 24062656)
1401 McKinney Street, Suite 1900
Houston, TX 77010
Telephone: (713) 752-4200
Email: kpeguero@jw.com
mcaavanaugh@jw.com

Co-Counsel for the Debtors and Debtors in Possession

MAYER BROWN LLP

Charles S. Kelley (TX Bar No. 11199580)
700 Louisiana Street, Suite 3400
Houston, TX 77002-2730
Telephone: (713) 238-3000
Email: ckelley@mayerbrown.com

-and-

Thomas S. Kiriakos (admitted *pro hac vice*)
Louis S. Chiappetta (admitted *pro hac vice*)
71 S. Wacker Drive
Chicago, IL 60606
Telephone: (312) 701-0600
Email: tkiriakos@mayerbrown.com
lchiappetta@mayerbrown.com

-and-

Adam C. Paul (admitted *pro hac vice*)
Lucy F. Kweskin (admitted *pro hac vice*)
1221 Avenue of the Americas
New York, NY 10020-1001
Telephone: (212) 506-2500
Email: apaul@mayerbrown.com
lkweskin@mayerbrown.com

Counsel for the Debtors and Debtors in Possession

Schedule A

Schedule of Assumed Executory Contracts and Unexpired Leases

Exhibit 6

Confirmation Hearing Notice

**IN THE UNITED STATES BANKRUPTCY COURT
FOR THE SOUTHERN DISTRICT OF TEXAS
HOUSTON DIVISION**

In re:)	
)	Chapter 11
GWG Holdings, Inc., <i>et al.</i> , ¹)	Case No. 22-90032 (MI)
)	
Debtors.)	(Jointly Administered)
)	

**NOTICE OF HEARING TO CONSIDER CONFIRMATION OF DEBTORS’ JOINT
CHAPTER 11 PLAN**

PLEASE TAKE NOTICE THAT on April 21, 2023, the United States Bankruptcy Court for the Southern District of Texas (the “Court”) entered an order [Docket No. 1681²] (the “Disclosure Statement Order”): (a) authorizing the above-captioned debtors and debtors in possession (collectively, the “Debtors”) to solicit votes on the *Debtors’ Second Amended Joint Chapter 11 Plan* [Docket No. 1678] (as may be amended, supplemented, or modified from time to time and including all exhibits and supplements thereto, the “Plan”);³ (b) approving the *Disclosure Statement for the Debtors’ Second Amended Joint Chapter 11 Plan* [Docket No. 1682] (the “Disclosure Statement”) as containing “adequate information” pursuant to section 1125 of the Bankruptcy Code; (c) approving the solicitation documents to be included in the solicitation packages; (d) approving procedures for soliciting, receiving, and tabulating votes on the Plan and for filing objections to the Plan; and (e) scheduling certain dates with respect thereto.

PLEASE TAKE FURTHER NOTICE THAT the hearing to consider confirmation of the Plan (the “Confirmation Hearing”) will commence on **June 15, 2023 at 1:30 p.m. (prevailing Central Time)**, before the Honorable Marvin Isgur, in the United States Bankruptcy Court for the Southern District of Texas, located at 515 Rusk Street, Courtroom 404, Houston, Texas, 77002. Please be advised that the Confirmation Hearing may be continued from time to time by the Court or the Debtors without further notice other than by such adjournment being announced in open court or by a notice of adjournment filed with the Court and served on other parties entitled to notice.

You may participate in the hearing either in person or by an audio and video connection. Audio communication will be by use of the Court’s dial-in facility. You may access the facility at

¹ The Debtors in these chapter 11 cases, along with the last four digits of each Debtor’s federal tax identification number, are: GWG Holdings, Inc. (2607); GWG Life, LLC (6955); GWG Life USA, LLC (5538) GWG DLP Funding IV, LLC (2598); GWG DLP Funding VI, LLC (6955) and GWG DLP Funding Holdings VI, LLC (6955). The location of Debtor GWG Holdings, Inc.’s principal place of business and the Debtors’ service address is 325 N. St. Paul Street, Suite 2650, Dallas, TX 75201. Further information regarding the Debtors and these chapter 11 cases is available at the website of the Debtors’ claims and noticing agent: <https://donlinrecano.com/gwg>.

² As modified pursuant to the order entered at docket 1692.

³ Capitalized terms used but not otherwise defined herein shall have the meanings ascribed to such terms in the Plan, Disclosure Statement, or the Disclosure Statement Order, as applicable.

(832) 917-1510. Once connected, you will be asked to enter the conference room number. Judge Isgur's conference room number is 954554. Video communication will be by use of the GoToMeeting platform. Connect via the free GoToMeeting application or click the link on Judge Isgur's home page. The meeting code is "JudgeIsgur". Click the settings icon in the upper right corner and enter your name under the personal information setting. Hearing appearances must be made electronically in advance of both electronic and in-person hearings. To make your appearance, click the "Electronic Appearance" link on Judge Isgur's home page. Select the case name, complete the required fields and click "Submit" to complete your appearance.

CRITICAL INFORMATION REGARDING VOTING ON THE PLAN

Voting Record Date. The Voting Record Date is February 24, 2023, which is the date for determining which Holders of Claims or Interests in the Voting Classes are entitled to vote on the Plan.

Voting Deadline. The deadline for voting on the Plan is **May 31, 2023 at 4:00 p.m. (prevailing Central Time)** (the "Voting Deadline"). If you received a Solicitation Package, including a Ballot, and intend to vote on the Plan you must: (a) follow the instructions on the Ballot carefully; (b) complete all of the required information on the Ballot; and (c) execute and return your completed Ballot according to and as set forth in detail in the voting instructions on the Ballot so that it is actually received by the Debtors' solicitation agent, Donlin Recano & Company, Inc. (the "Solicitation Agent"), on or before the Voting Deadline. A failure to follow such instructions may disqualify your vote.

Confirmation Objection Deadline. The deadline for filing objections to confirmation of the Plan is **May 31, 2023 at 11:59 p.m. (prevailing Central Time)** (the "Confirmation Objection Deadline"). Objections to the relief sought at the Confirmation Hearing must (a) be in writing; (b) conform to the Bankruptcy Rules, the Bankruptcy Local Rules, and any orders of the Court; (c) state the name, address, phone number, and e-mail address of the objecting party and the amount and nature of the Claim or Interest of such entity, if any; (d) state, with particularity, the legal and factual basis for the objection and, if practicable, a proposed modification to the Plan (or related materials) that would resolve such objection; and (e) be filed with the Court (contemporaneously with a proof of service) upon the applicable notice parties so to be actually received on or before the Confirmation Objection Deadline. Objections that fail to comply with this Order will not be considered by the Court.

CRITICAL INFORMATION REGARDING OBJECTING TO THE PLAN

ARTICLE VIII OF THE PLAN CONTAINS RELEASE, EXCULPATION, AND INJUNCTION PROVISIONS. YOU ARE ADVISED TO REVIEW AND CONSIDER THE PLAN CAREFULLY BECAUSE YOUR RIGHTS MIGHT BE AFFECTED THEREUNDER.

Important information regarding the release, exculpation, and injunction provisions in the Plan.⁴

Article VIII.C of the Plan contains the following release (the “Release”):

PURSUANT TO SECTION 1123(B) OF THE BANKRUPTCY CODE, IN EXCHANGE FOR GOOD AND VALUABLE CONSIDERATION, THE ADEQUACY OF WHICH IS HEREBY CONFIRMED, ON AND AFTER THE EFFECTIVE DATE, EACH RELEASED PARTY (BUT NO NON-RELEASED PARTY) IS, AND IS DEEMED HEREBY TO BE, FULLY, CONCLUSIVELY, ABSOLUTELY, UNCONDITIONALLY, IRREVOCABLY, AND FOREVER RELEASED AND DISCHARGED BY THE DEBTORS, THE WIND DOWN DEBTORS, AND THEIR ESTATES, AND ANY PERSON SEEKING TO EXERCISE THE RIGHTS OF THE DEBTORS OR THEIR ESTATES, INCLUDING ANY SUCCESSORS TO THE DEBTORS OR ANY ESTATES REPRESENTATIVES APPOINTED OR SELECTED PURSUANT TO SECTION 1123(B)(3) OF THE BANKRUPTCY CODE, IN EACH CASE ON BEHALF OF THEMSELVES AND THEIR RESPECTIVE SUCCESSORS, ASSIGNS, AND REPRESENTATIVES, AND ANY AND ALL OTHER ENTITIES WHO MAY PURPORT TO ASSERT ANY CAUSE OF ACTION, DIRECTLY OR DERIVATIVELY, BY, THROUGH OR FOR THE DEBTORS OR THEIR ESTATES, FROM ANY AND ALL CLAIMS AND CAUSES OF ACTION, WHETHER KNOWN OR UNKNOWN, INCLUDING ANY DERIVATIVE CLAIMS, ASSERTED OR ASSERTABLE ON BEHALF OF THE DEBTORS, WHETHER KNOWN OR UNKNOWN, FORESEEN OR UNFORESEEN, MATURED OR UNMATURED, EXISTING OR HEREAFTER ARISING, CONTINGENT OR NON-CONTINGENT, IN LAW, EQUITY, CONTRACT, TORT OR OTHERWISE, EXCEPT FOR ANY CLAIMS RELATED TO ANY ACT OR OMISSION THAT IS DETERMINED IN A FINAL ORDER TO HAVE CONSTITUTED ACTUAL FRAUD, WILLFUL MISCONDUCT, INTENTIONAL BREACH OF FIDUCIARY DUTY, OR GROSS NEGLIGENCE, THAT THE DEBTORS, THE WIND DOWN DEBTORS, OR THEIR ESTATES, INCLUDING ANY SUCCESSORS TO THE DEBTORS OR ANY ESTATES REPRESENTATIVE APPOINTED OR SELECTED PURSUANT TO SECTION 1123(B) OF THE BANKRUPTCY CODE, WOULD HAVE BEEN LEGALLY ENTITLED TO ASSERT IN THEIR OWN RIGHT (WHETHER INDIVIDUALLY OR COLLECTIVELY) OR ON BEHALF OF THE HOLDER OF ANY CLAIM OR INTEREST IN, A DEBTOR OR OTHER ENTITY, OR THAT ANY HOLDER OF ANY CLAIM AGAINST, OR INTEREST IN, A DEBTOR OR OTHER ENTITY COULD HAVE ASSERTED ON BEHALF OF THE DEBTORS, BASED ON OR RELATING TO, OR IN ANY MANNER ARISING FROM, IN WHOLE OR IN PART, THE DEBTORS (INCLUDING THE CAPITAL STRUCTURE, MANAGEMENT, OWNERSHIP OR OPERATION THEREOF), THE BUSINESS OR CONTRACTUAL ARRANGEMENT BETWEEN THE DEBTORS AND ANY RELEASED PARTY, ANY SECURITIES ISSUED BY THE DEBTORS AND THE OWNERSHIP THEREOF, THE ASSERTION OR ENFORCEMENT OF RIGHTS AND REMEDIES AGAINST THE DEBTORS, THE DEBTORS’ IN- OR OUT-OF-COURT RESTRUCTURING EFFORTS,

⁴ The Plan provisions referenced herein are for summary purposes only and do not include all provisions of the Plan that may affect your rights. If there is any inconsistency between the provisions set forth herein and the Plan, the Plan governs. You should read the Plan before completing this Ballot.

ANY AVOIDANCE ACTIONS (BUT EXCLUDING AVOIDANCE ACTIONS BROUGHT AS COUNTERCLAIMS OR DEFENSES TO CLAIMS ASSERTED AGAINST THE DEBTORS), INTERCOMPANY TRANSACTIONS BETWEEN OR AMONG A DEBTOR AND ANOTHER DEBTOR, THE FORMULATION, PREPARATION, DISSEMINATION, NEGOTIATION, OR FILING OF THE DISCLOSURE STATEMENT, THE PLAN (INCLUDING, FOR THE AVOIDANCE OF DOUBT, THE PLAN SUPPLEMENT), THE VIDA DIP FINANCING FACILITY, THE VIDA EXIT FINANCING FACILITY, OR ANY WIND DOWN TRANSACTION, CONTRACT, INSTRUMENT, RELEASE, OR OTHER AGREEMENT OR DOCUMENT (INCLUDING ANY LEGAL OPINION REQUESTED BY ANY ENTITY REGARDING ANY TRANSACTION, CONTRACT, INSTRUMENT, DOCUMENT OR OTHER AGREEMENT CONTEMPLATED BY THE PLAN OR THE RELIANCE BY ANY RELEASED PARTY ON THE PLAN OR THE CONFIRMATION ORDER IN LIEU OF SUCH LEGAL OPINION) CREATED OR ENTERED INTO IN CONNECTION WITH THE DISCLOSURE STATEMENT, THE VIDA EXIT FINANCING FACILITY DOCUMENTS, THE PLAN, OR THE PLAN SUPPLEMENT, BEFORE OR DURING THE CHAPTER 11 CASES, THE CHAPTER 11 CASES, THE FILING OF THE CHAPTER 11 CASES, THE PURSUIT OF CONFIRMATION, THE ADMINISTRATION AND IMPLEMENTATION OF THE PLAN, INCLUDING THE ISSUANCE OR DISTRIBUTION OF SECURITIES PURSUANT TO THE PLAN, OR THE DISTRIBUTION OF PROPERTY UNDER THE PLAN, OR UPON ANY RELATED ACT OR OMISSION, TRANSACTION, AGREEMENT, EVENT, OR OTHER OCCURRENCE RELATED OR RELATING TO ANY OF THE FOREGOING TAKING PLACE ON OR BEFORE THE EFFECTIVE DATE RELATED OR RELATING TO THE FOREGOING INCLUDING ALL RELIEF OBTAINED BY THE DEBTORS IN THE CHAPTER 11 CASES. FOR THE AVOIDANCE OF DOUBT, THE LBM RELEASED PARTIES, TO THE EXTENT THAT LBM HAS NOT WITHDRAWN FROM THE SETTLEMENT DESCRIBED IN ARTICLE IV.I OF THIS PLAN, SHALL CONSTITUTE RELEASED PARTIES WITH RESPECT TO THIS DEBTOR RELEASE.

NOTWITHSTANDING ANYTHING TO THE CONTRARY IN THE FOREGOING, THE RELEASES SET FORTH ABOVE DO NOT RELEASE: (1) POST-EFFECTIVE DATE OBLIGATIONS OF ANY PARTY OR ENTITY UNDER THE PLAN, THE CONFIRMATION ORDER, ANY WIND DOWN TRANSACTION, OR ANY OTHER DOCUMENT, INSTRUMENT, OR AGREEMENT (INCLUDING THOSE SET FORTH IN THE PLAN SUPPLEMENT) EXECUTED TO IMPLEMENT THE PLAN, INCLUDING THE VIDA EXIT FINANCING FACILITY DOCUMENTS, OR ANY CLAIM OR OBLIGATION ARISING UNDER THE PLAN; (2) THE RIGHTS OF ANY HOLDER OF ALLOWED CLAIMS TO RECEIVE DISTRIBUTIONS UNDER THE PLAN; (3) THE RETAINED CAUSES OF ACTION; (4) ANY CLAIMS RELATED TO ANY ACT OR OMISSION THAT IS DETERMINED IN A FINAL ORDER TO HAVE CONSTITUTED ACTUAL FRAUD, WILLFUL MISCONDUCT, INTENTIONAL BREACH OF FIDUCIARY DUTY, OR GROSS NEGLIGENCE; (5) THE DEBTORS' PREPETITION LEGAL COUNSEL SOLELY WITH RESPECT TO CLAIMS OR CAUSES OF ACTION ARISING FROM SUCH COUNSEL'S PREPETITION ADVICE TO THE DEBTORS AND/OR ANY FORMER DIRECTORS OR OFFICERS OF THE DEBTORS OTHER THAN ADVICE DIRECTLY RELATING TO THE PREPARATION AND FILING OF THE CHAPTER 11 CASES (IT BEING UNDERSTOOD ANY PREPETITION ADVICE

TO THE DEBTORS RELATING TO PREPETITION TRANSACTIONS BETWEEN THE DEBTORS AND BENEFICIENT SHALL NOT CONSTITUTE ADVICE DIRECTLY RELATING TO THE PREPARATION AND FILING OF THE CHAPTER 11 CASES); OR (6) ANY NON-RELEASED PARTY.

ENTRY OF THE CONFIRMATION ORDER SHALL CONSTITUTE THE BANKRUPTCY COURT'S APPROVAL, PURSUANT TO BANKRUPTCY RULE 9019, OF THE FOREGOING DEBTOR RELEASE, WHICH INCLUDES BY REFERENCE EACH OF THE RELATED PROVISIONS AND DEFINITIONS CONTAINED IN THE PLAN, AND FURTHER, SHALL CONSTITUTE THE BANKRUPTCY COURT'S FINDING THAT THE DEBTOR RELEASE IS: (A) IN EXCHANGE FOR THE GOOD AND VALUABLE CONSIDERATION PROVIDED BY THE RELEASED PARTIES, INCLUDING, WITHOUT LIMITATION, THE RELEASED PARTIES' CONTRIBUTIONS TO FACILITATING THE WIND DOWN TRANSACTIONS AND IMPLEMENTING THE PLAN; (B) A GOOD FAITH SETTLEMENT AND COMPROMISE OF THE CLAIMS RELEASED BY THE DEBTOR RELEASE; (C) IN THE BEST INTERESTS OF THE DEBTORS AND ALL HOLDERS OF CLAIMS AND INTERESTS; (D) FAIR, EQUITABLE, AND REASONABLE; (E) GIVEN AND MADE AFTER DUE NOTICE AND OPPORTUNITY FOR HEARING; AND (F) A BAR TO ANY OF THE DEBTORS, THE WIND DOWN DEBTORS, OR THE DEBTORS' ESTATES ASSERTING ANY CLAIM OR CAUSE OF ACTION RELEASED PURSUANT TO THE DEBTOR RELEASE.

"RELEASED PARTY" MEANS, COLLECTIVELY, AND IN EACH CASE IN THEIR RESPECTIVE CAPACITIES AS SUCH AND SUBJECT TO THE LIMITATIONS SET FORTH IN ARTICLE VIII.C HEREOF: (A) (I) THE DEBTORS AND THE WIND DOWN DEBTORS, (II) VIDA, (III) THE BONDHOLDER COMMITTEE AND EACH OF ITS MEMBERS, (IV) ANTHONY R. HORTON, IN HIS CAPACITIES AS AN INDEPENDENT DIRECTOR AND DIRECTOR OF THE DEBTORS, (V) JEFFREY S. STEIN, IN HIS CAPACITIES AS AN OFFICER, AN INDEPENDENT DIRECTOR, AND A DIRECTOR OF THE DEBTORS, (VI) MICHAEL A. TUCKER, IN HIS CAPACITY AS AN OFFICER OF THE DEBTORS, (VII) THE DLP INDEPENDENT DIRECTORS, (VIII) FTI CONSULTING, INC., (IX) PJT PARTNERS LP, AND (X) ANY OTHER PROFESSIONAL RETAINED BY THE DEBTORS, THE INDEPENDENT DIRECTORS, THE DLP INDEPENDENT DIRECTORS, OR THE BONDHOLDER COMMITTEE BY ORDER OF THE BANKRUPTCY COURT IN THE CHAPTER 11 CASES OR ANY PROFESSIONAL RETAINED BY ANY OF THE MEMBERS OF THE BONDHOLDER COMMITTEE, EACH IN SUCH CAPACITY; AND (B) SOLELY TO THE EXTENT AND ON THE TERMS AND CONDITIONS SET FORTH IN THIS PLAN, THE LBM RELEASED PARTIES.

"NON-RELEASED PARTIES" SHALL MEAN ANY ENTITIES THAT ARE NOT RELEASED PARTIES, WHICH ENTITIES SHALL INCLUDE, WITHOUT LIMITATION, BENEFICIENT, ITS CURRENT AND FORMER DIRECTORS AND OFFICERS (INCLUDING, WITHOUT LIMITATION, BRADLEY K. HEPPNER, THOMAS O. HICKS, BRUCE W. SCHNITZER, DENNIS P. LOCKHART, AND PETER T. CANGANY), HCLP NOMINEES, L.L.C., THE DEBTORS' FORMER DIRECTORS

AND OFFICERS (INCLUDING, WITHOUT LIMITATION, MURRAY HOLLAND AND TIMOTHY EVANS) IN THEIR CAPACITY OR CAPACITIES AS SUCH, AND ANY ENTITIES AFFILIATED WITH OR OTHERWISE RELATED TO THE FOREGOING.

Article VIII.E of the Plan provides for an exculpation of certain parties (the “**Exculpation**”):

EXCEPT AS OTHERWISE EXPRESSLY STATED IN THIS PLAN OR THE CONFIRMATION ORDER, AS OF THE EFFECTIVE DATE, EACH EXCULPATED PARTY SHALL BE DEEMED TO BE RELEASED AND EXCULPATED FROM ANY CLAIM, OBLIGATION, CAUSE OF ACTION, OR LIABILITY FOR ANY EXCULPATED CLAIM, EXCEPT FOR CLAIMS RELATED TO ANY ACT OR OMISSION THAT IS DETERMINED IN A FINAL ORDER TO HAVE CONSTITUTED INTENTIONAL BREACH OF FIDUCIARY DUTY, ACTUAL FRAUD, WILLFUL MISCONDUCT, OR GROSS NEGLIGENCE, BUT IN ALL RESPECTS EACH DEBTOR AND EACH EXCULPATED PARTY SHALL BE ENTITLED TO REASONABLY RELY UPON THE ADVICE OF COUNSEL WITH RESPECT TO THEIR DUTIES AND RESPONSIBILITIES PURSUANT TO THE PLAN. THE EXCULPATED PARTIES HAVE, AND UPON THE CONSUMMATION OF THE PLAN, SHALL BE DEEMED TO HAVE, PARTICIPATED IN GOOD FAITH AND IN COMPLIANCE WITH APPLICABLE LAW WITH REGARD TO THE RESTRUCTURING OF CLAIMS AND INTERESTS IN THE CHAPTER 11 CASES AND IN CONNECTION WITH THE WIND DOWN TRANSACTIONS, THE NEGOTIATION, FORMULATION, OR PREPARATION OF THE WIND DOWN DOCUMENTS OR RELATED AGREEMENTS, INSTRUMENTS, OR OTHER DOCUMENTS (INCLUDING, FOR THE AVOIDANCE OF DOUBT, PROVIDING ANY LEGAL OPINION REQUESTED BY ANY ENTITY REGARDING ANY TRANSACTION, CONTRACT, INSTRUMENT, DOCUMENT, OR OTHER AGREEMENT CONTEMPLATED BY THE PLAN OR THE RELIANCE BY ANY RELEASED PARTY ON THE PLAN OR THE CONFIRMATION ORDER IN LIEU OF SUCH LEGAL OPINION) IN CONNECTION WITH THE PLAN, AND THE SOLICITATION OF THE PLAN AND DISTRIBUTIONS PURSUANT TO THE PLAN AND, THEREFORE, ARE NOT, AND ON ACCOUNT OF SUCH DISTRIBUTIONS SHALL NOT BE, LIABLE AT ANY TIME FOR THE VIOLATION OF ANY APPLICABLE LAW, RULE, OR REGULATION GOVERNING THE SOLICITATION OF ACCEPTANCES OR REJECTIONS OF THE PLAN OR SUCH DISTRIBUTIONS MADE PURSUANT TO THE PLAN, EXCEPT FOR CLAIMS RELATED TO ANY ACT OR OMISSION THAT IS DETERMINED IN A FINAL ORDER TO HAVE CONSTITUTED INTENTIONAL BREACH OF FIDUCIARY DUTY, ACTUAL FRAUD, WILLFUL MISCONDUCT, OR GROSS NEGLIGENCE. THE DEBTORS AND THE CREDITOR PROPONENTS AGREE THAT (1) NEITHER THE ACT ITSELF OF FILING OR PROSECUTING A MOTION TO APPROVE A SETTLEMENT OF ANY ESTATE CAUSES OF ACTION WITH BENEFICIENT, ANY OF ITS AFFILIATES OR RELATED PARTIES, AND/OR ANY OTHER NON-RELEASED PARTY NOR THE ACT ITSELF OF FILING OR PROSECUTING ANY OBJECTION TO ANY SUCH SETTLEMENT IN AND OF ITSELF CONSTITUTES AN INTENTIONAL BREACH OF FIDUCIARY DUTY, AND (2) ANY CLAIMS THAT THE DEBTORS OR THE CREDITOR PROPONENTS MAY SEEK TO BRING AGAINST ANY EXCULPATED PARTY SHALL BE LIMITED TO ANY ACTIONS OF SUCH EXCULPATED PARTY

SOLELY AFTER THE DATE OF EXECUTION OF THE MEDIATION AGREEMENT; PROVIDED THAT ANY SUCH CLAIMS MUST BE FILED EXCLUSIVELY IN THE BANKRUPTCY COURT AND IN ACCORDANCE WITH THE FEDERAL RULES OF CIVIL PROCEDURES, AND SUCH CLAIMS SHALL BE PLED WITH SPECIFICITY WITH RESPECT TO THE WHO, WHAT, WHEN, WHERE, AND HOW OF THE ALLEGED WRONGFUL CONDUCT.

“EXCULPATED PARTY” MEANS, COLLECTIVELY, AND IN EACH CASE, IN THEIR RESPECTIVE CAPACITIES AS SUCH: (A) JEFFREY S. STEIN, IN HIS CAPACITIES AS AN OFFICER, AN INDEPENDENT DIRECTOR, AND A DIRECTOR OF THE DEBTORS; (B) ANTHONY R. HORTON, IN HIS CAPACITIES AS AN INDEPENDENT DIRECTOR AND DIRECTOR OF THE DEBTORS; (C) MICHAEL A. TUCKER, IN HIS CAPACITY AS AN OFFICER OF THE DEBTORS; (D) THE NON-MANAGEMENT DIRECTORS, IN THEIR CAPACITY AS SUCH; (E) THE DLP INDEPENDENT DIRECTORS, IN THEIR CAPACITY AS SUCH; (F) THE MEMBERS OF THE BONDHOLDER COMMITTEE, IN THEIR CAPACITY AS SUCH; (G) ANY PROFESSIONAL RETAINED BY THE DEBTORS, THE INDEPENDENT DIRECTORS, THE DLP INDEPENDENT DIRECTORS, THE BONDHOLDER COMMITTEE, IN SUCH PROFESSIONALS’ CAPACITY AS SUCH; AND (H) ANY PROFESSIONAL RETAINED BY ANY OF THE MEMBERS OF THE BONDHOLDER COMMITTEE, EACH IN SUCH PROFESSIONALS’ CAPACITY AS SUCH.

“EXCULPATED CLAIM” MEANS ANY CLAIM RELATED TO ANY ACT OR OMISSION FROM THE PETITION DATE TO THE EFFECTIVE DATE IN CONNECTION WITH, RELATING TO, OR ARISING OUT OF: (A) THE CHAPTER 11 CASES; (B) THE FORMULATION, PREPARATION, DISSEMINATION, OR NEGOTIATION OF ANY DOCUMENT IN CONNECTION WITH THE CHAPTER 11 CASES; (C) ANY CONTRACT, INSTRUMENT, RELEASE, AND/OR OTHER AGREEMENT OR DOCUMENT CREATED OR ENTERED INTO IN CONNECTION WITH THE CHAPTER 11 CASES; (D) THE PURSUIT OF CONSUMMATION; AND/OR (E) THE FILING, ADMINISTRATION, AND/OR IMPLEMENTATION OF THE CHAPTER 11 CASES, OR THE DISTRIBUTION OF PROPERTY IN CONNECTION THEREWITH OR THEREUNDER; PROVIDED, THAT, FOR THE AVOIDANCE OF DOUBT, ANY PREPETITION ADVICE PROVIDED BY ANY LEGAL PROFESSIONALS IN CONNECTION WITH PREPETITION TRANSACTIONS BETWEEN THE DEBTORS AND BENEFICIENT SHALL NOT CONSTITUTE ANY ACT OR OMISSION THAT IS COVERED BY THIS DEFINITION OF EXCULPATED CLAIM; PROVIDED, FURTHER, THAT, NOTWITHSTANDING THE FOREGOING, EXCULPATED CLAIMS SHALL NOT INCLUDE ANYTHING RELATED TO ANY ACT OR OMISSION THAT IS DETERMINED IN A FINAL ORDER TO HAVE CONSTITUTED ACTUAL FRAUD, WILLFUL MISCONDUCT, INTENTIONAL BREACH OF FIDUCIARY DUTY, OR GROSS NEGLIGENCE.

Article VIII.G of the Plan establishes an injunction (the “**Injunction**”):

EXCEPT AS OTHERWISE EXPRESSLY PROVIDED IN THE PLAN OR THE CONFIRMATION ORDER OR FOR OBLIGATIONS OR DISTRIBUTIONS REQUIRED

TO BE PAID PURSUANT TO THE PLAN OR THE CONFIRMATION ORDER, ALL ENTITIES WHO HAVE HELD, HOLD, OR MAY HOLD CLAIMS THAT HAVE BEEN RELEASED PURSUANT TO ARTICLE VIII HEREOF ARE PERMANENTLY ENJOINED, FROM AND AFTER THE EFFECTIVE DATE, FROM TAKING ANY OF THE FOLLOWING ACTIONS AGAINST, AS APPLICABLE, THE DEBTORS, THE RELEASED PARTIES, OR THE EXCULPATED PARTIES: (1) COMMENCING OR CONTINUING IN ANY MANNER ANY ACTION OR OTHER PROCEEDING OF ANY KIND ON ACCOUNT OF OR IN CONNECTION WITH OR WITH RESPECT TO ANY OF THE CLAIMS OR INTERESTS RELEASED HEREUNDER; (2) ENFORCING, ATTACHING, COLLECTING, OR RECOVERING BY ANY MANNER OR MEANS ANY JUDGMENT, AWARD, DECREE, OR ORDER AGAINST SUCH ENTITIES ON ACCOUNT OR IN CONNECTION WITH OR WITH RESPECT TO ANY CLAIMS OR INTERESTS RELEASED HEREUNDER; (3) CREATING, PERFECTING, OR ENFORCING ANY LIEN OR ENCUMBRANCE OF ANY KIND AGAINST SUCH ENTITIES OR THE PROPERTY OF SUCH ENTITIES ON ACCOUNT OR IN CONNECTION WITH OR WITH RESPECT TO ANY CLAIMS OR INTERESTS RELEASED HEREUNDER; (4) ASSERTING ANY RIGHT OF SETOFF, SUBROGATION, OR RECOUPMENT OF ANY KIND AGAINST ANY OBLIGATION DUE FROM SUCH ENTITIES OR AGAINST THE PROPERTY OR THE ESTATES OF SUCH ENTITIES ON ACCOUNT OR IN CONNECTION WITH OR WITH RESPECT TO ANY CLAIMS OR INTERESTS RELEASED HEREUNDER, UNLESS SUCH HOLDER HAS FILED A MOTION REQUESTING THE RIGHT TO PERFORM SUCH SETOFF ON OR BEFORE THE EFFECTIVE DATE, AND NOTWITHSTANDING AN INDICATION OF A CLAIM OR INTEREST OR OTHERWISE THAT SUCH HOLDER ASSERTS, HAS, OR INTENDS TO PRESERVE ANY RIGHT OF SETOFF PURSUANT TO APPLICABLE LAW OR OTHERWISE; AND (5) COMMENCING OR CONTINUING IN ANY MANNER ANY ACTION OR OTHER PROCEEDING OF ANY KIND ON ACCOUNT OF OR IN CONNECTION WITH OR WITH RESPECT TO ANY CLAIMS OR INTERESTS RELEASED OR SETTLED PURSUANT TO THIS PLAN.

UPON ENTRY OF THE CONFIRMATION ORDER, ALL HOLDERS OF CLAIMS AND INTERESTS AND THEIR RESPECTIVE CURRENT AND FORMER EMPLOYEES, AGENTS, OFFICERS, DIRECTORS, PRINCIPALS, AND DIRECT AND INDIRECT AFFILIATES SHALL BE ENJOINED FROM TAKING ANY ACTIONS TO INTERFERE WITH THE IMPLEMENTATION OR CONSUMMATION OF THIS PLAN. EXCEPT AS OTHERWISE SET FORTH IN THE CONFIRMATION ORDER, EACH HOLDER OF AN ALLOWED CLAIM OR ALLOWED INTEREST, AS APPLICABLE, BY ACCEPTING, OR BEING ELIGIBLE TO ACCEPT, DISTRIBUTIONS UNDER THIS PLAN SHALL BE DEEMED TO HAVE CONSENTED TO THE INJUNCTION PROVISIONS SET FORTH HEREIN.

ADDITIONAL INFORMATION

Obtaining Solicitation Materials. If you would like to obtain a copy of the Disclosure Statement Order, the Plan, the Disclosure Statement, the Bondholder Summary, the Solicitation Procedures, the Plan Supplement, or related documents, such materials are available free of charge by: (a) accessing the Debtors' restructuring website at

<https://www.donlinrecano.com/Clients/gwg/Index>; (b) writing to Donlin, Recano & Company, Inc., Re: GWG Holdings, Inc., et al., P.O. Box 199043, Blythebourne Station, Brooklyn, NY 11219; (c) calling 1 (888) 508-2507 (U.S. toll free); or (d) emailing gwginfo@donlinrecano.com. You may also obtain copies of any pleadings filed in the Chapter 11 Cases for a fee via PACER at <https://ecf.txsb.uscourts.gov/>.

The Plan Supplement. The Debtors will file the Plan Supplement (as defined in the Plan) on or before five business days prior to the Voting Deadline, and will serve notice on parties in interest, which will: (a) inform parties that the Debtors filed the Plan Supplement; (b) list the information contained in the Plan Supplement; and (c) explain how parties may obtain copies of the Plan Supplement.

BINDING NATURE OF THE PLAN

IF CONFIRMED, THE PLAN SHALL BIND ALL HOLDERS OF CLAIMS AND INTERESTS TO THE MAXIMUM EXTENT PERMITTED BY APPLICABLE LAW, WHETHER OR NOT SUCH HOLDER WILL RECEIVE OR RETAIN ANY PROPERTY OR INTEREST IN PROPERTY UNDER THE PLAN, HAS FILED A PROOF OF CLAIM IN THE CHAPTER 11 CASES, OR FAILED TO VOTE TO ACCEPT OR REJECT THE PLAN OR VOTED TO REJECT THE PLAN.

Houston, Texas
April ____, 2023

Respectfully Submitted,

JACKSON WALKER LLP

Kristhy M. Peguero (TX Bar No. 24102776)
Matthew D. Cavanaugh (TX Bar No. 24062656)
1401 McKinney Street, Suite 1900
Houston, TX 77010
Telephone: (713) 752-4200
Email: kpeguero@jw.com
mcaavanaugh@jw.com

Co-Counsel for the Debtors and Debtors in Possession

MAYER BROWN LLP

Charles S. Kelley (TX Bar No. 11199580)
700 Louisiana Street, Suite 3400
Houston, TX 77002-2730
Telephone: (713) 238-3000
Email: ckelley@mayerbrown.com

-and-

Thomas S. Kiriakos (admitted *pro hac vice*)
Louis S. Chiappetta (admitted *pro hac vice*)
71 S. Wacker Drive
Chicago, IL 60606
Telephone: (312) 701-0600
Email: tkiriakos@mayerbrown.com
lchiappetta@mayerbrown.com

-and-

Adam C. Paul (admitted *pro hac vice*)
Lucy F. Kweskin (admitted *pro hac vice*)
1221 Avenue of the Americas
New York, NY 10020-1001
Telephone: (212) 506-2500
Email: apaul@mayerbrown.com
lkweskin@mayerbrown.com

Counsel for the Debtors and Debtors in Possession

Exhibit 7
Beneficial Bondholder Notice

**IN THE UNITED STATES BANKRUPTCY COURT
FOR THE SOUTHERN DISTRICT OF TEXAS
HOUSTON DIVISION**

In re:)	Chapter 11
)	
GWG Holdings, Inc., <i>et al.</i> , ¹)	Case No. 22-90032 (MI)
)	
Debtors.)	(Jointly Administered)
)	

**NOTICE TO BENEFICIAL HOLDERS OF
L BONDS WHO FILED PROOFS OF CLAIM**

On April 21, 2023, the United States Bankruptcy Court for the Southern District of Texas (the “Court”) entered an order [Docket No. 1681²] (the “Disclosure Statement Order”) authorizing the above-captioned debtors and debtors in possession (collectively, the “Debtors”) to solicit votes on the *Debtors’ Second Amended Joint Chapter 11 Plan* [Docket No. 1678] (as may be amended, supplemented, or modified from time to time and including all exhibits and supplements thereto, the “Plan”).³

All Holders of L Bonds are entitled to vote to accept or reject the Plan based on the principal amount of their Bonds. However, certain Holders of Bonds whose bonds are held through a bank, brokerage, or other intermediary (the “Indirect-Held Bonds”) are entitled to vote to accept or reject the Plan ***only through*** “Beneficial Holder Ballots” distributed by such bank, brokerage, or other intermediary based on their records as of the February 24, 2023 Voting Record Date.

According to our records you hold an Indirect-Held Bond. You will be entitled to vote to accept or reject the Plan on account of your Indirect-Held Bonds ***solely through*** “Beneficial Holder Ballots” distributed by your bank, brokerage, or other intermediary, or a third-party retained by them for such purpose. In the event you do not promptly receive such a Ballot, please contact your bank, brokerage, investment advisor, other representative relating to the account in which your Indirect-Held Bonds are held.

¹ The Debtors in these chapter 11 cases, along with the last four digits of each Debtor’s federal tax identification number, are: GWG Holdings, Inc. (2607); GWG Life, LLC (6955); GWG Life USA, LLC (5538) GWG DLP Funding IV, LLC (2598); GWG DLP Funding VI, LLC (6955) and GWG DLP Funding Holdings VI, LLC (6955). The location of Debtor GWG Holdings, Inc.’s principal place of business and the Debtors’ service address is 325 N. St. Paul Street, Suite 2650, Dallas, TX 75201. Further information regarding the Debtors and these chapter 11 cases is available at the website of the Debtors’ claims and noticing agent: <https://donlinrecano.com/gwg>.

² As modified pursuant to the order entered at docket 1692.

³ Capitalized terms used but not otherwise defined herein shall have the meanings ascribed to such terms in the Plan, Disclosure Statement, or the Disclosure Statement Order, as applicable.

Please note that, if you hold L Bonds that are registered with the Debtors in your own name, you will be separately be entitled to vote on a Ballot distributed directly by Donlin, Recano & Company, Inc.

If you have any questions concerning any of the foregoing, please contact Donlin, Recano & Company, Inc. by calling 1 (888) 508-2507 (U.S. toll free) or via email at gwginfo@donlinrecano.com.

Exhibit C

Valuation Analysis

THE INFORMATION CONTAINED HEREIN IS NOT A PREDICTION OR GUARANTEE OF THE ACTUAL MARKET VALUE THAT MAY BE REALIZED FROM ANY SECURITIES OR INTERESTS TO BE ISSUED PURSUANT TO THE SECOND AMENDED PLAN. THE INFORMATION IS PRESENTED SOLELY FOR THE PURPOSE OF PROVIDING ADEQUATE INFORMATION UNDER SECTION 1125 OF THE BANKRUPTCY CODE IN RESPECT OF THE SOLICITATION OF HOLDERS OF CLAIMS AND INTERESTS ENTITLED TO VOTE TO ACCEPT OR REJECT THE SECOND AMENDED PLAN TO MAKE AN INFORMED JUDGMENT ABOUT THE SECOND AMENDED PLAN AND SHOULD NOT BE USED OR RELIED UPON FOR ANY OTHER PURPOSE, INCLUDING THE PURCHASE OR SALE OF CLAIMS AGAINST OR INTERESTS IN THE DEBTORS OR ANY OF THEIR AFFILIATES.⁶³

Solely for the purposes of the Second Amended Plan and the Disclosure Statement, PJT Partners LP (“PJT”), as investment banker to the Debtors, has considered several potential indicia of value to inform Holders of Allowed Claims and Allowed Interests as to the potential estimated range of the Total Enterprise Value of the Wind Down Debtors for purposes of the Second Amended Plan (the “Second Amended Plan TEV”). The Second Amended Plan TEV is based on financial and other information provided to PJT by the Debtors’ management and third-party advisors and information provided by other sources. The analysis herein is as of June 15, 2023, with an assumed Effective Date of the Second Amended Plan of July 15, 2023. The analysis herein utilizes market data as of April 14, 2023. The valuation estimates set forth herein represent the consideration of select indicia of valuation available to PJT and does not reflect the application of all customary valuation techniques given certain limitations in the availability of projections and other information, as described below.

The estimated values set forth herein: (a) assume the Second Amended Plan and the transactions contemplated thereby are consummated; (b) do not constitute an opinion on the terms and provisions or fairness from a financial point of view to any person of the consideration to be received by such person under the Second Amended Plan; (c) do not constitute a recommendation to any Holder of Allowed Claims or Allowed Interests as to how such person should vote or otherwise act with respect to the Second Amended Plan; and (d) do not necessarily reflect the actual market value that might be realized through a sale or liquidation of the Wind Down Debtors.

As discussed in Article II of the Disclosure Statement, pursuant to the Second Amended Plan, the Debtors will transfer their assets to the Wind Down Trust and the Litigation Trust, for the benefit of the Holders of Allowed Claims and Allowed Interests, which assets will be liquidated over time. The value of the ultimate recoveries from the trusts paid to the Holders of Allowed Claims and Allowed Interests will vary depending on the amount of consideration obtained by the Wind Down Trustee and the Litigation Trustee in connection with the orderly liquidation of assets of each of the trusts over time, after reduction for any and all expenses.

Over the course of the negotiations that resulted in the Second Amended Plan, the Debtors, the Bondholder Committee, and LBM did not reach a consensus regarding a precise Second Amended Plan TEV. However, the calculation of a precise Second Amended Plan TEV was determined by the Debtors not

⁶³ All capitalized terms used but not otherwise defined herein shall have the meanings ascribed to them in the Disclosure Statement for the Debtors’ Modified Second Amended Joint Chapter 11 Plan, Submitted by the Debtors, the Bondholder Committee, and L Bond Management, LLC, as Co-Proponents (the “Disclosure Statement”) to which this analysis is attached as Exhibit C.

to be necessary for the Debtors, the Bondholder Committee, and LBM to reach agreement on the terms of the Second Amended Plan. As a result, PJT considered several potential indicia of value to inform Holders of Allowed Claims and Allowed Interest as to the potential estimated range of the Second Amended Plan TEV. The components of value are described below.

Asset	Estimated Second Amended Plan TEV Range		Note
	Low	High	
Equity in Beneficient (Wind Down Trust)	\$ 0	\$ 1,428	1
Equity in Life Settlements Portfolio (Wind Down Trust)	0	78	2
Equity in FOXO (Wind Down Trust)	3	3	3
Estate Claims and Causes of Action (Litigation Trust)	155	382	4
Trust Operating Costs (Wind Down and Litigation Trusts)	(23)	(23)	5
Total	\$ 136	\$ 1,869	

Note 1 – Given the pending Avalon Business Combination, PJT has not been provided access to financial projections from Beneficient on which it could rely in order to perform a traditional valuation analysis. Further, the early-stage nature of Beneficient may give rise to a potentially wide range of valuation outcomes. Additionally, the GWG common equity holdings in Beneficient are currently junior in priority to approximately \$1.4 billion of senior debt and senior preferred equity that would receive a recovery prior to the holders of the Beneficient common equity in the event of a liquidation of Beneficient and its assets. Therefore, at the low end of the range, the above estimated Second Amended Plan TEV reflects a value of \$0 ascribed to GWG’s equity in Beneficient under a downside scenario whereby value is reflective of only the underlying investments held by Beneficient (approximately \$542 million as of December 31, 2022), and excludes goodwill or any option value associated with the business enterprise, which may not be material in the event of a liquidation), with such underlying investments value amounting to less than the approximately \$1.4 billion in priority claims. At the high end of the range, the estimated Second Amended Plan TEV relies on the value of Beneficient equity as implied by the pending SPAC transaction (as described in Article II and Article IV.A.2.d of the Disclosure Statement) involving a third party merger counterparty. As described in Article II.A of the Disclosure Statement, the achievement of such value is subject to certain risks, including but not limited to the risk of the SPAC transaction ultimately closing, the impact of broader macroeconomic factors on the trading value of the public securities issued therefrom, and the ability of Beneficient to execute on its business plan.

Note 2 – The value of the Debtors’ residual equity interest in the life settlements portfolio reflects analysis undertaken by the Debtors’ life settlements consultant, ClearLife. ClearLife valued the residual cashflows arising from the life settlements portfolio, after taking into account the secured debt financing. The valuation utilized 10,000 Monte Carlo simulations to arrive at a range of possible values for the Debtor’s residual equity interest. In the above estimated Plan TEV, the higher number reflects the 1st percentile of that range of values, meaning that 1% of simulations had values equal to or greater than this number. The lower number reflects the 99th percentile of that range of values, meaning that 99% of cases had values greater than or equal to this number. The lower end of the range of values also reflects the risk that the debt might not be repaid in full in a downside scenario.

Note 3 – The value of FOXO reflects current market trading value of GWG interest in FOXO as of April 14, 2023.

Note 4 – As described in Article IV of the Second Amended Plan, the Litigation Trust will retain the estate claims and causes of action which will be pursued over time by the Litigation Trust. The ultimate recovery from the pursuit of the estate claims and causes of action is uncertain and has been estimated by the Investigations Committee in consultation with its counsel (as described in Article II.A.4 of the Disclosure Statement). The low end of the range is the low recovery assuming a “Low” valuation of Beneficient. The high end of the range is the high recovery assuming a “High” valuation of Beneficient.

Note 5 – The trust operating costs represent an estimate of operating costs for the Wind Down Trust and Litigation Trust for 3 years, including Litigation Trust funding, trustee fees, and other costs, as analyzed and prepared by the Debtors’ financial advisor, FTI Consulting.

For purposes of the analysis herein, PJT assumed that no material changes that would affect estimated value will occur between the date of the Disclosure Statement and the assumed Effective Date of the Second Amended Plan. In addition, PJT assumed that there will be no material change in economic, monetary, market, industry, and other conditions that would impact any of the material information made available to PJT between the date of the Disclosure Statement and the assumed Effective Date. PJT also assumed the Avalon Business Combination would continue to be pursued on terms and conditions materially and substantially the same as the terms and conditions contemplated in Beneficient’s filed S-4 as of March 6, 2023. PJT has insufficient information to form a view regarding the likelihood of consummation of the Avalon Business Combination and thus makes no representation as to the achievability or reasonableness of such assumptions. Neither the Debtors nor PJT undertakes any obligation to update or revise statements to reflect events or circumstance that arise after the date of the Disclosure Statement or to reflect the occurrence of unanticipated events.

PJT’s analysis herein does not constitute an opinion as to the fairness from a financial point of view of the consideration to be received or paid under the Second Amended Plan, of the terms and provisions of the Second Amended Plan, or with respect to any other matters.

THE ANALYSIS HEREIN REFLECTS WORK PERFORMED BY PJT ON THE BASIS OF INFORMATION IN RESPECT OF THE BUSINESSES AND ASSETS OF THE DEBTORS AVAILABLE TO PJT AS OF APRIL 14, 2023. IT SHOULD BE UNDERSTOOD THAT, ALTHOUGH SUBSEQUENT DEVELOPMENTS MAY HAVE AFFECTED OR MAY AFFECT THE ANALYSIS HEREIN, PJT DOES NOT HAVE ANY OBLIGATION TO UPDATE, REVISE, OR REAFFIRM ITS ESTIMATES OR THE ANALYSIS HEREIN AND DOES NOT INTEND TO DO SO.

PJT DID NOT INDEPENDENTLY VERIFY THE FINANCIAL INFORMATION THAT PJT USED IN THE ANALYSIS HEREIN, AND NO INDEPENDENT VALUATIONS OR APPRAISALS OF THE DEBTORS OR THEIR ASSETS OR LIABILITIES WERE SOUGHT OR OBTAINED IN CONNECTION THEREWITH. THE ANALYSIS HEREIN WAS DEVELOPED SOLELY FOR PURPOSES OF THE SECOND AMENDED PLAN AND THE ANALYSIS OF POTENTIAL RELATIVE RECOVERIES TO CREDITORS THEREUNDER. THE ANALYSIS HEREIN DOES NOT PURPORT TO BE AN OPINION AND DOES NOT PURPORT TO REFLECT OR CONSTITUTE AN APPRAISAL, LIQUIDATION VALUE, OR ESTIMATE OF THE ACTUAL MARKET VALUE THAT MAY BE REALIZED THROUGH THE SUBSEQUENT SALE OF ANY BENEFICIAL INTERESTS IN THE TRUSTS TO BE ISSUED PURSUANT TO, OR ASSETS SUBJECT TO, THE SECOND AMENDED PLAN, WHICH MAY BE SIGNIFICANTLY DIFFERENT THAN THE AMOUNTS SET FORTH HEREIN.

THE VALUE OF AN OPERATING BUSINESS IS SUBJECT TO NUMEROUS UNCERTAINTIES AND CONTINGENCIES THAT ARE DIFFICULT TO PREDICT AND WILL FLUCTUATE WITH CHANGES IN FACTORS AFFECTING THE FINANCIAL CONDITION AND PROSPECTS OF SUCH A BUSINESS. AS A RESULT, THE

ANALYSIS HEREIN OF THE VALUE OF THE DEBTORS' INTERESTS IN BENEFICIENT IS NOT NECESSARILY INDICATIVE OF ACTUAL OUTCOMES, WHICH MAY BE SIGNIFICANTLY MORE OR LESS FAVORABLE THAN THOSE SET FORTH HEREIN. BECAUSE SUCH ESTIMATES ARE INHERENTLY SUBJECT TO UNCERTAINTIES, NONE OF THE DEBTORS, PJT, OR ANY OTHER PERSON ASSUMES RESPONSIBILITY FOR THEIR ACCURACY.

IN ADDITION, THE POTENTIAL VALUATION OF BENEFICIAL INTERESTS IN THE TRUSTS IS SUBJECT TO ADDITIONAL UNCERTAINTIES AND CONTINGENCIES, ALL OF WHICH ARE DIFFICULT TO PREDICT. ACTUAL MARKET PRICES OF BENEFICIAL INTERESTS IN THE TRUSTS AT ISSUANCE WILL DEPEND UPON, AMONG OTHER THINGS, PREVAILING INTEREST RATES, CONDITIONS IN THE FINANCIAL MARKETS, THE ANTICIPATED INITIAL BENEFICIAL INTERESTS IN THE TRUSTS OF PREPETITION CREDITORS, SOME OF WHICH MAY PREFER TO LIQUIDATE THEIR INVESTMENT IMMEDIATELY RATHER THAN HOLD THEIR INVESTMENT ON A LONG-TERM BASIS, THE POTENTIALLY DILUTIVE IMPACT OF CERTAIN EVENTS, AND OTHER FACTORS THAT GENERALLY INFLUENCE THE PRICES OF BENEFICIAL INTERESTS IN THE TRUSTS.

The analysis herein does not constitute a recommendation to any Holder of Allowed Claims or Allowed Interests, or any other person as to how such person should vote or otherwise act with respect to the Second Amended Plan. PJT has not been requested to, and does not express any view as to, the potential value of the beneficial interests in the Trusts on issuance or at any other time.

THE SUMMARY SET FORTH HEREIN DOES NOT PURPORT TO BE A COMPLETE DESCRIPTION OF THE INDICIA OF VALUE CONSIDERED BY PJT. THE PREPARATION OF AN ANALYSIS SIMILAR TO THE ANALYSIS HEREIN INVOLVES VARIOUS DETERMINATIONS AS TO THE MOST APPROPRIATE AND RELEVANT METHODS OF FINANCIAL ANALYSIS AND THE APPLICATION OF THESE METHODS IN THE PARTICULAR CIRCUMSTANCES AND, THEREFORE, SUCH AN ANALYSIS IS NOT READILY SUITABLE TO SUMMARY DESCRIPTION. THE INDICIA OF VALUE CONSIDERED BY PJT IS NOT NECESSARILY INDICATIVE OF ACTUAL VALUES OR FUTURE RESULTS, WHICH MAY BE SIGNIFICANTLY MORE OR LESS FAVORABLE THAN THOSE DESCRIBED HEREIN.

PJT IS ACTING AS INVESTMENT BANKER TO THE DEBTORS, AND HAS NOT BEEN AND WILL NOT BE RESPONSIBLE FOR, AND HAS NOT AND WILL NOT PROVIDE ANY TAX, ACCOUNTING, ACTUARIAL, LEGAL, OR OTHER SPECIALIST ADVICE TO THE DEBTORS OR ANY OTHER PARTY IN CONNECTION WITH THE DEBTORS' CHAPTER 11 CASES, THE SECOND AMENDED PLAN OR OTHERWISE.

Exhibit D

Letter from Brad K. Heppner

quinn emanuel trial lawyers | new york

51 Madison Avenue, 22nd Floor, New York, New York 10010-1601 | TEL (212) 849-7000 FAX (212) 849-7100

April 21, 2023

Thomas S. Kiriakos, Esq.
Mayer Brown LLP
71 S. Wacker Dr.
Chicago, Illinois 60606

Steven J. Reisman, Esq.
Katten Muchin Rosenman LLP
50 Rockefeller Plaza
New York, New York 10020-16055

Re: In re GWG Holdings, Inc., et al., No. 22-90032 (MI) (Bankr. S.D. Tex.); Debtors Further Modified Second Amended Joint Chapter 11 Plan (the “Plan”)

We are counsel to Brad K. Heppner. Mr. Heppner submits this letter, in which Beneficient Company Holdings, L.P. and The Beneficient Company Group, L.P. join, to set forth the reasons they vigorously dispute the merits of the allegations made with respect to the Retained Causes of Action and in the Bondholder Complaint as well as the valuations ascribed to those alleged claims in the Disclosure Statement.

A. MR. HEPPNER AND BENEFICIENT WILL VIGOROUSLY DEFEND AGAINST THE RETAINED CAUSES OF ACTION AND CLAIMS ASSERTED IN THE PROPOSED COMPLAINT

Beneficient filed the Objection To The Standing Motion [ECF No. 1451]. Separately, Mr. Heppner filed the Objection To The Standing Motion And Joinder In Beneficient’s Objection [ECF No. 1457]. A third party, HCLP Nominees, LLC also objected to the Standing Motion [ECF No. 1496]. These Objections argue, among other things, that the Proposed Complaint is legally and factually flawed. They also argue that prosecuting the Proposed Complaint risks depleting Estate value and impairing creditors’ recoveries by harming what they contend is the Estates’ most valuable asset, the investment in Beneficient, through the prosecution of costly and protracted litigation that is devoid of merit.

According to the Debtors, “all potential claims and causes of action against the proposed defendants asserted in the Committee’s Standing Motion and the Proposed Complaint attached thereto are among those that will be included as Retained Causes of Action.” Mr. Heppner and Beneficient dispute that any valid claims exist, intend to vigorously prosecute and defend against those claims, and respond partially to the assertions of the Debtors and the Bondholder Committee as follows and with a full reservation of rights.

First, as a preliminary matter, even on their face, and without delving into the merits, Mr. Heppner and Beneficient believe prosecution of the Retained Causes of Action cannot provide a significant enough recovery to creditors to justify the risks of harm that such litigation poses to GWG’s interest in Beneficient.

Second, the Retained Causes of Action lack merit. They are predicated on the made-for-litigation theory that Beneficient was overvalued to such a significant degree when GWG made its investments in the company that GWG was actually insolvent at the time of those investments, and failed to receive reasonably equivalent value in exchange. But, Beneficient’s value, and by extension GWG’s solvency at the time it made investments into Beneficient, was established by far superior indicators, e.g., contemporaneous valuations performed by reputable firms and actual, third-party transactions. At least two transactions negotiated at arm’s length have validated Mr. Heppner’s initial investment thesis, and they bookend the period of time when the transactions took place that are the subject of the Retained Causes of Action. An Ankura valuation as of

quinn emanuel urquhart & sullivan, llp

ATLANTA | AUSTIN | BEIJING | BERLIN | BOSTON | BRUSSELS | CHICAGO | DALLAS | DOHA | HAMBURG | HONG KONG | HOUSTON | LONDON | LOS ANGELES | MANNHEIM | MIAMI | MUNICH | NEUILLY-LA DEFENSE | NEW YORK | PARIS | PERTH | RIYADH | SALT LAKE CITY | SAN FRANCISCO | SEATTLE | SHANGHAI | SILICON VALLEY | STUTTGART | SYDNEY | TOKYO | WASHINGTON, DC | ZURICH

May 31, 2018, which ascribed a value of \$2.196 billion to Beneficient, was prepared in connection with the arm's-length transaction between Beneficient and third-party market participant that is a large institutional asset manager (the "2018 Transaction"). And, that third-party asset manager concurred with an allocation of value in that transaction that was predicated on that valuation. The second transaction is the special-purpose-acquisition-company ("SPAC") transaction with Avalon Acquisition Inc. (NASDAQ: AVAC) ("Avalon"), that is, the Avalon Business Combination, which has an implied valuation of \$3.3 billion. That implies that the Debtors' interest in Beneficient is worth in excess of \$1.4 billion.¹ These valuations were corroborated during the interim period by additional valuations prepared by Ankura. As demonstrated by the 2018 Transaction and Avalon Business Combination transactions, from 2018 through today, Beneficient has continuously been valued at over \$2 billion. Given Beneficient's value, GWG received reasonably equivalent value in exchange for each of the (fully-disclosed) transfers it made to Beneficient, defeating not only the fraudulent transfer claims but also those alleging breach of fiduciary duty.

Third, the Proposed Complaint suffers from various factual inaccuracies, substituting shock and hyperbole for substance. GWG had no affiliation with Mr. Heppner or Beneficient when it decided in 2018 to invest in Beneficient to "expand [the Debtors'] business to include a greater, more diversified portfolio of assets."² The Proposed Complaint alleges that Mr. Heppner teamed up with highly successful, and truly independent individuals, including two former presidents of Federal Reserve Banks, to perpetuate a "Ponzi scheme" involving the sale of L Bonds. The critical details of how these individuals defrauded investors or converted assets are glaringly absent from either this Disclosure Statement or the Proposed Complaint. The Proposed Complaint does not allege anything was "stolen" or that investors were "defrauded." Instead, it tries to criminalize one company's (GWG's) informed decision to invest in another company (Beneficient) with a different business line to diversify its portfolio, which is perfectly legal and was disclosed to L Bond investors in myriad filings with the U.S. Securities and Exchange Commission ("SEC"). The Debtors' Chief Restructuring Officer, an Estate fiduciary, considers allegations about a Ponzi scheme to be inaccurate and has satisfied himself after extensive diligence that Beneficient "is a functioning, viable business."³ As a matter of law, Mr. Heppner did not breach his fiduciary duties as alleged in the Proposed Complaint.⁴ Among other things:

¹ See Beneficient Registration Statement (Form S-4) (Dec. 9, 2022), available at <https://www.sec.gov/Archives/edgar/data/1775734/000119312522301885/d406382ds4.htm>. An updated Beneficient Registration Statement (Form S-4) was filed on April 19, 2023 and is available at <https://www.sec.gov/Archives/edgar/data/1775734/000119312523106636/d406382ds4a.htm>.

² GWG Holdings Inc., 2017 Annual Report (Form 10-K) (Mar. 29, 2018), at p. 3, available at https://www.sec.gov/Archives/edgar/data/1522690/000121390018003608/f10k2017_gwgholdings.htm.

³ ECF No. 1346 (Statement Of The Independent Committees In Support Of Temporarily Continuing The Seal) (Jan. 13, 2023), at ¶ 5; ECF No. 1160 (Tr., Hr'g Dec. 1, 2022), at 26:1-26:16.

⁴ Mr. Heppner is named in the following breach of fiduciary duty counts of the Proposed Complaint: Count 3 (Heppner), Count 4 (Heppner), Count 8 (Heppner), Count 11 (Heppner), Count 14 (Heppner), Count 15 (Heppner), and Count 16 (Heppner). (Heppner also is named in Count 22 for unjust enrichment).

- Mr. Heppner was neither the “controlling shareholder” of GWG nor in control of the GWG’s or Beneficient’s boards of directors;
- GWG’s investments in Beneficient—and more generally its pivot away from the life settlement business in order to diversify its business lines—were both well known to L Bond investors, having been disclosed in multiple filings with the SEC; and
- Payments Mr. Heppner made to related parties also were disclosed clearly in GWG’s SEC filings as was the compensation Mr. Heppner received from Beneficient (which was for the performance of executive services and reviewed by independent consultants).

Similarly, the Proposed Bondholder Complaint lacks the requisite legal precision to state viable claims. Decisions and transfers are not tied to individuals with dates and times. And, the Bondholder Committee resorts to a nebulous “upon-information-and-belief” qualifier 38 separate times,⁵ mostly in connection with allegations relating to Mr. Heppner or entities affiliated with him. The pervasive lack of specificity as it relates to Mr. Heppner is especially telling considering it had access to wide-ranging Rule-2004 discovery, including several interviews with Mr. Heppner and a two-day deposition.

Fourth, Mr. Heppner contests the allegations surrounding GWG’s March 2021 8-K. The Bondholder Committee alleges that the March 2021 8-K was “authorized” to be filed by “the GWG Board, including its chair, Mr. Heppner.”⁶ That is wrong. As is typical and as required by regulations promulgated by the SEC, the March 2021 8-K was signed by company management—not the company’s directors, e.g., Mr. Heppner.

As a legal matter, Form 8-K does not require certifications by an issuer’s board of directors. Directors do not typically sign or authorize Form 8-K filings.⁷ Nor was it the purview of Mr. Heppner, then-Chairman of the Board of a public company (GWG), to authorize an Item 5.02, Form 8-K filing for GWG. That disclosure is the responsibility of management. Here, GWG management wrote, signed, and filed the March 2021 8-K on the advice of counsel. GWG attached correspondence from the Debtors’ former President and Chief Executive Officer (“CEO”) to its Amended Form 8-K filed on November 14, 2022 and a subsequent Form 8-K filed on December 2, 2022.⁸ The correspondence shows there is a significant dispute about whether the March 2021 8-K is “materially false.” According to GWG’s former CEO (i) while members of the Third Special Committee resigned after reviewing a proposed \$14.8 million capital contribution to Beneficient, in point of

⁵ Proposed Compl. ¶¶ 12, 16 & n. 5, 18, 19 & n. 7, 45, 47, 48, 50, 51, 55, 56, 57, 59, 95, 96, 97, 98, 99, 100, 101, 102, 103, 104, 105, 106, 110, 111, 113, 144, 145, 156, 157, 165 & n. 18, 243, 463.

⁶ Proposed Compl. ¶¶ 30-31.

⁷ Cf. 17 C.F.R. § 240.13a-14(a).

⁸ See GWG Holdings, Inc. Amended Current Report (Form 8-K/A) (Nov. 14, 2022) (“Amended March 2021 8-K”), Ex. 99.2, available at <https://www.sec.gov/Archives/edgar/data/1522690/000119312522284071/0001193125-22-284071-index.htm> (amending the March 2021 8-K and attaching correspondence from the former CEO and President to the Special Committee); GWG Holdings, Inc. Current Report (Form 8-K) (Dec. 2, 2022) (“December 2, 2022 8-K”), available at <https://www.sec.gov/ix?doc=/Archives/edgar/data/0001522690/000119312522296756/d415864d8k.htm> (attaching former President and CEO’s resignation letter and letter to the Board of Directors).

fact, GWG had accepted the Third Special Committee's recommendation that GWG receive a more senior security in Beneficient in exchange for that contribution;⁹ and (ii) management had a reasonable and good faith belief, based on the advice of counsel, that no disclosable disagreement with the resigning members of the Third Special Committee existed.¹⁰

The Disclosure Statement also states there are Retained Causes of Action relating to the October 2019 8-K. But, like the March 2021 8-K, the October 2019 8-K was signed and issued by management with the advice of counsel.

Finally, Mr. Heppner and Beneficient disagree with the argument that Beneficient requires GWG's consent to consummate the Avalon Business Combination. GWG does not have a contractual right to consent to the transaction. That GWG holds "limited voting rights" was disclosed publicly in filings with the SEC.¹¹ And, while GWG has no consent rights under the Business Combination Agreement, Avalon no longer insists on GWG's consent as a condition to closing.¹²

B. MR. HEPPNER AND BENEFICIENT STRONGLY DISPUTE THE VALUES ASCRIBED TO THE RETAINED CAUSES OF ACTION AND BELIEVE PROSECUTING THEM WILL RISK THE VALUE OF GWG'S EQUITY INTEREST IN BENEFICIENT

Mr. Heppner and Beneficient believe prosecuting the Retained Causes of Action cannot provide a significant enough recovery to creditors to justify the risks of harm that such litigation and its hyperbole can cause to GWG's equity interests in Beneficient.

First, the Disclosure Statement suggests there is a litigation recovery floor of \$155 million in chapter 11 cases and \$139.5 million in a chapter 7 liquidation.¹³ But, the real floor of any litigation—be it this litigation or virtually any other—is always zero (\$0).

Second, the Investigations Committee and Bondholder Committee estimate that the Litigation Trust will recover between \$151 million and \$505 million from claims arising from the Beneficient Separation Transactions, which were consummated to facilitate Beneficient's receipt of a trust charter from the State of Kansas—a key component of Beneficient's ability to execute on its business plan. The estimated damages are predicated on three bases: (i) a claim that GWG should have been paid a control premium in exchange for relinquishing its right to appoint a majority of the members of the Board of Beneficient's general partner (the "Designation Right"); (ii) a claim that the Beneficient Separation Transactions resulted in GWG having

⁹ Amended March 2021 8-K.

¹⁰ December 2, 2022 8-K.

¹¹ GWG 2018 Form 10-K pp. 24, 26, 48, available at https://www.sec.gov/Archives/edgar/data/1522690/000121390019012331/f10k2018_gwgholdings.htm.

¹² See Avalon Acquisition Inc., Form 8-K (April 18, 2023), at Item 1.02, available at https://www.sec.gov/ix?doc=/Archives/edgar/data/0001836478/000173112223000677/e4606_8-k.htm.

¹³ See Discl. Stmt. p. 4 (estimating "Range of Values" for "Retained Causes of Action" to be "\$155 million - \$382 million" under a chapter 11 plan and "\$139.5 million - \$343.8 million" in a chapter 7 liquidation).

to pay \$40 million under its senior secured credit agreement; and (iii) a claim that GWG was not adequately compensated for certain debt and equity conversion transactions. Mr. Heppner and Beneficient dispute that the Litigation Trust will be able to recover anything close to \$151 million on account of these claims. First, “control premiums” apply when a shareholder sells a controlling block of shares in a company. Here, GWG did not own a controlling block of shares, did not sell any of its equity interests in Beneficient, and relinquished only its non-transferable contractual right to designate a majority of the board of Beneficient’s general partner. And critically, GWG did so in order to preserve the value of its equity interests in Beneficient by enabling Beneficient to execute on its business plan. There are no precedents supporting the payment of any control premium under these circumstances. Moreover, even a cursory review of GWG’s credit agreement reveals that the Beneficient Separation Transactions did not result in a default under the agreement and that the \$40 million GWG paid in connection with an amendment to the agreement was not caused by the Beneficient Separation Transactions. And, based on the value ascribed to Beneficient in the Avalon Business Combination, the debt and equity conversion transactions that were consummated in connection with the Beneficient Separation Transactions resulted in a net benefit to GWG.

Third, the Investigations Committee and Bondholder Committee estimate that claims arising from the Ben Investments and/or subordination of Preferred C Units will result in recoveries of up to \$299 million. The values derived from third-party, arms’ length transactions, however, show that GWG received reasonably equivalent value in exchange for each of the investments, which would completely defeat any constructive fraudulent transfer claims predicated on the investments, and render any recovery on intentional fraudulent transfer or breach of fiduciary duty claims highly unlikely. Additionally, the \$299 million figure includes (i) a \$14.8 million investment that was returned to GWG shortly after it was made, and (ii) the investment of only \$79 million in exchange for \$10 million of BCG common stock and \$319 million BCH Preferred A-1 Units.

Fourth, the Bondholder Committee estimates that “Ponzi scheme allegations” could yield recovery of up to \$877 million. The Bondholder Committee fails to explain, however, exactly what claims would yield such recoveries, or how any claims predicated on the hyperbolic allegation that GWG was a “Ponzi scheme”—or, in other words, a fraudulent enterprise—could survive in the face of GWG’s repeated and specific disclosures regarding how the proceeds of the L Bonds would be used. And, the Debtors’ Chief Restructuring Officer has stated that Beneficient “is a functioning, viable business” and that GWG was not a Ponzi scheme.¹⁴

¹⁴ ECF No. 1346 (Statement Of The Independent Committees In Support Of Temporarily Continuing The Seal) (Jan. 13, 2023), at ¶ 5 (“[T]he Standing Motion accuses GWG of being a ‘classic Ponzi scheme,’ which it is not. It characterizes the actions of certain individuals in highly charged terms, like ‘siphoning,’ ‘looting,’ and ‘funneling.’ None of this language was necessary, and it is reasonable to believe that it could seriously harm an entity, like Ben, that is in the middle of negotiating a SPAC transaction, and attempting to attract investors”); ECF No. 1160 (Tr., Hr’g Dec. 1, 2022), at 26:1-26:16 ([DEBTORS’ CRO]: “[W]e have done a tremendous amount of due diligence with respect to Beneficient. I have conducted extensive meetings with the Board, with the management team, have toured the infrastructure and related facilities numerous times, have interviewed other members of the management team, have [had] our professionals engage[] extensively with their professionals, who are top tier. So I believe we are as comfortable as we can be ... that this is a functioning, viable business...”).

Fifth, the Investigations Committee and the Bondholder Committee estimate that the Retained Causes of Action relating to the March 2021 8-K and October 2018 8-K will generate recoveries of \$46 million and \$22 million, respectively, but they fail to state as they should that the disclosures were made with the advice of counsel or explain how they are calculating the estimated recoveries.

Sixth, the Investigations Committee and Bondholder Committee's estimated recoveries fail to adequately account for important variables that will reduce creditors' recoveries on account of the claims, e.g., (i) the potential fees and costs of prosecuting the Retained Causes of Action; (ii) the anticipated time-line for recovery; and (iii) the prospect of collection. While the Estates lump these variables together (along with the risk that the claims will not ultimately prevail) in a "33-67% discount rate," in point of fact, the litigation will likely cost tens of millions of dollars in fees on an hourly basis, or they will be a significant percentage of any recovery if incurred on a contingent basis. The suits could take years to prosecute. And, there are no assurances defendants could satisfy money judgments in the tens of millions of dollars.

Finally, the pursuit of the Retained Causes of Action discussed above poses significant risk to the asset that presents the best source of recovery to creditors—GWG's equity interests in Beneficient. Indeed, the Standing Motion and Proposed Complaint have already caused palpable harm to Beneficient. Among other things, the press associated with the Proposed Bondholder Complaint has perpetuated its false narrative and led at least one strategic investor to put its potential investment in the Avalon Business Combination on hold. Moreover, various state regulatory agencies, such as those associated with the State of Kansas, are closely monitoring the bankruptcy cases. And, at least one legislator is relying on the Bondholder Committee's allegations to introduce legislation that would harm Beneficient.¹⁵

Very truly yours,



James C. Tecce

Counsel to Brad K. Heppner

¹⁵ See Senate Bill No. 199 (By Senator Holland) (Session of 2023) ("An Act concerning financial institutions; relating to the technology enabled fiduciary financial institutions act; authorizing the state banking board to deny, suspend or revoke the charter of a fiduciary financial institution in certain circumstances; providing procedures therefor; requiring fiduciary financial institutions to purchase a surety bond; establishing a civil money penalty for violations"). Senator Holland also has raised concern that the Bondholder Committee could pursue claims against the State of Kansas. While any such claim would be devoid of merit—especially given that no funds originating at GWG Holdings were ever, or will ever be transferred by Beneficient to the State of Kansas—this is but one example of the kind of trouble that the Proposed Complaint has stirred up for Beneficient and, by extension, GWG Holdings.

Exhibit E

Liquidation Analysis

1) Introduction¹

Often called the “best interests” test, section 1129(a)(7) of the Bankruptcy Code requires that a bankruptcy court find, as a condition to confirmation, that a chapter 11 plan provides, with respect to each impaired class, that each holder of a claim or interest in such impaired class either (1) has accepted the plan or (2) will receive or retain under the plan property of a value that is not less than the amount that the non-accepting holder would receive or retain if the debtors liquidated under chapter 7.

To demonstrate that the Second Amended Plan satisfies the “best interests of creditors” test, the Debtors, with the assistance of their restructuring advisors, have prepared a hypothetical liquidation analysis (this “Liquidation Analysis”), based upon certain assumptions discussed in the Disclosure Statement and these accompanying notes. As reflected in the Liquidation Analysis, the Debtors believe that liquidation of the Debtors’ businesses under chapter 7 of the Bankruptcy Code would result in substantial diminution in the value to be realized by Holders of Claims and Interests as compared to distributions contemplated under the Second Amended Plan. Consequently, the Debtors believe that Confirmation of the Second Amended Plan will provide a greater return to Holders of Claims and Interests than would a liquidation under chapter 7 of the Bankruptcy Code.

The Liquidation Analysis sets forth estimated computed recoveries for each Class of Claims and Interests that may be realizable upon the disposition of assets pursuant to a hypothetical chapter 7 liquidation of the Debtors’ Estates. The Liquidation Analysis reflects the estimated cash proceeds, net of liquidation and wind-down related costs, which are projected to be realized if the Debtors were to be liquidated in accordance with chapter 7 of the Bankruptcy Code and under the assumptions set forth herein.

Underlying the Liquidation Analysis are numerous estimates and assumptions that, although developed and considered reasonable by the Debtors’ management and its advisors, are inherently subject to significant business, economic, regulatory, and competitive uncertainties and contingencies beyond the control of the Debtors, their management, and their advisors. Accordingly, there can be no assurance that the computed recoveries reflected in the Liquidation Analysis would be realized if the Debtors were, in fact, to undergo such a liquidation, and actual results could materially differ from the results herein. The underlying financial information in the Liquidation Analysis was not compiled or examined by any independent accountants. Any balances reflected herein are unaudited and presented as such.

¹ Capitalized terms used but not otherwise defined herein shall have the meanings ascribed to them in the Debtors’ Modified Second Amended Joint Chapter 11 Plan, Submitted by the Debtors, the Bondholder Committee, and L Bond Management, LLC, as Co-Proponents (as may be amended, modified, or supplemented from time to time, the “Second Amended Plan”) or the Disclosure Statement for the Debtors’ Modified Second Amended Joint Chapter 11 Plan, Submitted by the Debtors, the Bondholder Committee, and L Bond Management, LLC as Co-Proponents (as may be amended, modified, or supplemented from time to time, the “Disclosure Statement”), as applicable.

2) Basis of Presentation

The Liquidation Analysis has been prepared on a consolidated basis assuming that the Debtors converted the current chapter 11 cases for the Debtors to cases under chapter 7 of the Bankruptcy Code on or about June 15, 2023 (the “Conversion Date”) and that such liquidation will take approximately three years. There can be no assurance that the liquidation would be completed in a limited time frame, nor is there any assurance that the recoveries assigned to the assets would in fact be realized. Under Bankruptcy Code section 704, a trustee shall, among other duties, collect and reduce to money the property of the estate and close such estate as expeditiously as is compatible with the best interests of parties in interest.

This Liquidation Analysis assumes that on the Conversion Date, the Bankruptcy Court would appoint a chapter 7 trustee to oversee the liquidation of the Debtors’ Estates. In this hypothetical scenario, the chapter 7 trustee would satisfy claims by converting all assets of these Debtors to cash by selling or monetizing the individual assets of these Debtors and abandoning assets which cannot be sold. The cash amount (the “Net Proceeds Available for Distribution”) that would be available for satisfaction of Allowed Claims and Allowed Interests would consist of the net proceeds resulting from the disposition of the assets and properties of the Debtors, augmented by any cash held by the Debtors at the time of the commencement of the liquidation activities. The Liquidation Analysis does not include estimates for any tax consequences that may be triggered upon the liquidation.

The determination of the costs of, and proceeds from, the hypothetical liquidation of the Debtors’ assets in a chapter 7 case is an uncertain process involving the extensive use of significant estimates and assumptions that, although considered reasonable by the Debtors based upon their business judgment and input from their advisors, are inherently subject to significant business and economic uncertainties and contingencies beyond the control of the Debtors, their management and their advisors. Inevitably, some assumptions in the Liquidation Analysis would not materialize in an actual chapter 7 liquidation, and unanticipated events and circumstances could materially adversely affect the ultimate results in an actual chapter 7 liquidation. The Liquidation Analysis was prepared for the sole purpose of generating a reasonable good faith estimate of the proceeds that would be generated if the Debtors’ assets were liquidated in accordance with chapter 7 of the Bankruptcy Code. The Liquidation Analysis is not intended and should not be used for any other purpose. The underlying financial information in the Liquidation Analysis was not compiled or examined by any independent accountants. NEITHER THE DEBTORS NOR THEIR ADVISORS MAKE ANY REPRESENTATION OR WARRANTY THAT THE ACTUAL RESULTS WOULD OR WOULD NOT APPROXIMATE THE ESTIMATES AND ASSUMPTIONS REPRESENTED IN THE LIQUIDATION ANALYSIS. ACTUAL RESULTS COULD VARY MATERIALLY. FURTHER, NO AMOUNT IN THE LIQUIDATION ANALYSIS SHOULD BE RELIED ON FOR ANY PURPOSE OTHER THAN THE LIQUIDATION ANALYSIS.

In preparing the Liquidation Analysis, the Debtors estimated Allowed Claims based upon a review of the filed claims and the Debtors’ available financial information to account for other known liabilities, as necessary. In addition, the Liquidation Analysis includes estimates for Claims not currently asserted in the chapter 11 cases, but which could be asserted and allowed in a chapter 7 liquidation, including unpaid chapter 11 Administrative Claims, Secured Claims, and chapter 7 administrative Claims such as wind-down costs. Therefore, the Debtors’ estimates of Allowed

Claims set forth in the Liquidation Analysis should not be relied on for any other purpose, including determining the value of any distribution to be made on account of Allowed Claims and Allowed Interests under the Second Amended Plan. NOTHING CONTAINED IN THE LIQUIDATION ANALYSIS IS INTENDED TO BE OR CONSTITUTES A CONCESSION, ADMISSION, OR ALLOWANCE OF ANY CLAIM OR INTEREST BY THE DEBTORS. THE ACTUAL AMOUNT OR PRIORITY OF ALLOWED CLAIMS IN THE CHAPTER 11 CASES COULD MATERIALLY DIFFER FROM THE ESTIMATED AMOUNTS SET FORTH IN THE LIQUIDATION ANALYSIS.

3) Stakeholder Recovery Comparison: Chapter 7 vs. Chapter 11

As reflected in the hypothetical Liquidation Analysis below, the Debtors believe that liquidation of the Debtors' businesses under chapter 7 of the Bankruptcy Code would result in substantial diminution in the value to be realized by Holders of Claims and Interests as compared to distributions contemplated under the Second Amended Plan. As a result, the Debtors believe that Consummation of the Second Amended Plan will provide a substantially greater return to constituents than would any liquidation under chapter 7 of the Bankruptcy Code.

A number of factors in a chapter 7 liquidation would affect the chapter 7 trustee's ability to sell the Debtors' remaining assets. Among other things, the primary risks are expected to include challenges associated with liquidating the assets in an expedited manner due to various operational challenges and costs associated with the monetization of certain assets. Additionally, there is a risk of losing access to personnel necessary to effectuate an orderly and value-maximizing wind down of the assets. Absent such access to personnel, the chapter 7 trustee may not be able to realize estimated recoveries of the assets.

Further, the Debtors' Estates would incur the costs of payment of a statutorily allowed commission to the chapter 7 trustee, as well as the costs of counsel and other professionals retained by the chapter 7 trustee. The Debtors believe that such amounts, over the same liquidation time period under the Second Amended Plan, would exceed the amount of expenses that will be incurred in implementing the Second Amended Plan and winding up the affairs of the Debtors in the chapter 11 Cases. Under the Second Amended Plan, the Debtors contemplate an orderly administration and winding down of the Debtors' Estates by parties that are familiar with the Debtors, their assets and affairs, and their creditors and liabilities. Such familiarity will allow the Debtors to complete liquidation of the remaining assets and distribute the net proceeds to creditors more efficiently and expeditiously than a chapter 7 trustee. Additionally, the Debtors' Estates would suffer additional delays and inefficiencies, as a chapter 7 trustee and his/her counsel will require time to acquire the knowledge and skills to successfully complete the administration of the Debtors' Estates. Also, following conversion to chapter 7, a new time period for the filing of Claims would commence under Bankruptcy Rule 1019(2), possibly resulting in the filing of additional Claims against the Debtors' Estates.

LIQUIDATION ANALYSIS

(\$ in Millions)

Liquidation Analysis		Notes	Chapter 7		Chapter 11	
			Low	High	Low	High
Estimated Recoveries						
Cash & Cash Equivalents	A		\$ 38.1	\$ 38.1	\$ 38.1	\$ 38.1
Interest in Beneficial	B		-	1,285.2	-	1,428.0
Interest in FOXO	C		2.9	2.9	3.3	3.3
Policy Portfolio Equity Interest ^[1]	D		-	10.7	-	78.0
Estate Claims & Causes of Action	E		139.5	343.8	155.0	382.0
Total Estimated Recoveries			\$ 180.6	\$ 1,680.7	\$ 196.4	\$ 1,929.4
(-) Wind Down Costs	F		\$ (17.4)	\$ (17.4)	\$ (17.4)	\$ (17.4)
(-) Litigation Recovery Costs	G		(1.2)	(1.2)	(1.2)	(1.2)
(-) Chapter 11 Wind Down Trustee Fees	H		-	-	(2.1)	(2.1)
(-) Chapter 11 Litigation Trustee Fees	I		-	-	(1.8)	(1.8)
(-) Chapter 7 Trustee Fees	J		(21.5)	(68.3)	-	-
(-) Chapter 7 Incremental Costs	K		(1.0)	(1.0)	-	-
Net Proceeds Available for Distribution			\$ 139.5	\$ 1,592.9	\$ 173.9	\$ 1,906.9

Claims Recovery Analysis		Notes	Chapter 7				
Class - Type of Claims			Estimated Claim Amount	Total Proceeds (\$)		Total Recovery (%)	
				Low	High	Low	High
Administrative Claims & Priority Tax Claims	L		\$ 11.1	\$ 11.1	\$ 11.1	100.0%	100.0%
Vida DIP Claims ^[1]	M		-	59.5	-	100.0%	100.0%
Chapford DIP Facility Claims	N		-	-	-	N/A	N/A
DLP Secured Claims	O		-	-	-	N/A	N/A
Class 1 – Other Secured Claims	P		-	-	-	N/A	N/A
Class 2 – Other Priority Claims	Q		0.0	0.0	0.0	100.0%	100.0%

Class 3 – Bondholder Claims							
Class 3 – Indenture Fee and Expense Claim	R		2.4	2.4	2.4	100.0%	100.0%
Class 3 – Bondholder Claims (excluding LBM L Bond Claims)	S		1,295.3	50.9	1,219.9	3.9%	94.2%
Class 3 – LBM L Bond Claims	T		377.5	14.8	355.5	3.9%	94.2%
Total Class 3 – Bondholder Claims			1,675.2	68.0	1,577.8	4.1%	94.2%
Class 4(a) – General Unsecured Claims	U		20.4	0.8	4.0	4.1%	19.7%
Class 4(b) – GUC Convenience Claims	V		N/A	-	-	N/A	N/A
Class 5 – DLP Entity General Unsecured Claims	W		-	-	-	N/A	N/A
Class 6 – Intercompany Claims	X		N/A	-	-	N/A	N/A
Class 7 – Intercompany Interests	Y		N/A	-	-	N/A	N/A
Class 8 – Series 1 Preferred Interests	Z		42.6	-	-	0.0%	0.0%
Class 9 – Series 2 Preferred Interests	AA		88.1	-	-	0.0%	0.0%
Class 10 – Common Stock in GWGH	BB		N/A	-	-	N/A	N/A
Total Recovery			\$ 1,837.5	\$ 139.5	\$ 1,592.9		

Claims Recovery Analysis		Notes	Chapter 11				
Class - Type of Claims			Estimated Claim Amount	Total Proceeds (\$)		Total Recovery (%)	
				Low	High	Low	High
Administrative Claims & Priority Tax Claims	L		\$ 23.6	\$ 23.6	\$ 23.6	100.0%	100.0%
Vida DIP Claims ^[1]	M		-	-	-	100.0%	100.0%
Chapford DIP Facility Claims	N		-	-	-	N/A	N/A
DLP Secured Claims	O		-	-	-	N/A	N/A
Class 1 – Other Secured Claims	P		-	-	-	N/A	N/A
Class 2 – Other Priority Claims	Q		0.0	0.0	0.0	100.0%	100.0%

Class 3 – Bondholder Claims ^[2]							
Class 3 – Indenture Fee and Expense Claim	R		2.4	2.4	2.4	100.0%	100.0%
Class 3 – Bondholder Claims (excluding LBM L Bond Claims) ^[2]	S		1,295.3	117.1	1,452.9	9.0%	100.0%
Class 3 – LBM L Bond Claims ^[2]	T		377.5	29.0	423.4	7.7%	100.0%
Total Class 3 – Bondholder Claims^[2]			1,675.2	148.4	1,878.7	8.9%	100.0%
Class 4(a) – General Unsecured Claims	U		20.3	1.7	4.4	8.5%	21.9%
Class 4(b) – GUC Convenience Claims	V		0.1	0.1	0.1	100.0%	100.0%
Class 5 – DLP Entity General Unsecured Claims	W		-	-	-	N/A	N/A
Class 6 – Intercompany Claims	X		N/A	-	-	N/A	N/A
Class 7 – Intercompany Interests	Y		N/A	-	-	N/A	N/A
Class 8 – Series 1 Preferred Interests	Z		42.6	-	-	0.0%	0.0%
Class 9 – Series 2 Preferred Interests	AA		88.1	-	-	0.0%	0.0%
Class 10 – Common Stock in GWGH	BB		N/A	-	-	N/A	N/A
Total Recovery			\$ 1,850.0	\$ 173.9	\$ 1,906.9		

Chapter 11 Total Recovery in excess of Chapter 7 Total Recovery \$ 34.4 \$ 314.0

[1] The Vida DIP Claims are accounted for as paid in determination of the Policy Portfolio Equity Interest. In the event the Vida DIP Claims are not paid in full, the shortfall is reflected as paid in the Claims Recovery Analysis.

[2] Total Proceeds in excess of the Estimated Claim Amount reflect the payment of accrued interest on Bondholder Claims at a rate of 9% per annum per the Plan.

4) Notes to Liquidation Analysis

Recoveries

- A) Cash & Cash Equivalents: Estimated cash balances held in the Debtors' operating accounts as of the Conversion Date. Recovery on any cash is estimated at 100%. Cash available on the Conversion Date is dependent on several variables including the Debtors' actual operating disbursements and DIP funding prior to the Conversion Date.
- B) Interest in Beneficient: The Company holds interests in Ben LP and Ben LP's subsidiary Beneficient Company Holdings, L.P. Estimated recovery in a Chapter 11 scenario is based on the Valuation Analysis. Chapter 7 recovery ranges have been adjusted to reflect the estimated impact of a chapter 7 Trustee monetizing the Interest in Beneficient.
- C) Interest in FOXO: The Company holds interests in FOXO Technologies, Inc. Estimated recovery in a Chapter 11 scenario is based on the Valuation Analysis. Chapter 7 recovery ranges have been adjusted to reflect the estimated impact of a chapter 7 Trustee monetizing the Interest in FOXO.
- D) Policy Portfolio Equity Interest: The direct and indirect equity interests in DLP IV and DLP VI under a chapter 7 or under a chapter 11, the new successor entity, to be created after Confirmation under chapter 11. The recovery for the Policy Portfolio Equity Interest in both the chapter 7 and chapter 11 scenarios is after the payoff of the Vida DIP Claims. Estimated recovery in Chapter 11 scenario is based on the Valuation Analysis. Chapter 7 recovery ranges have been adjusted to reflect the estimated impact of a chapter 7 Trustee monetizing the Policy Portfolio Equity Interest.
- E) Estate Claims & Causes of Action: Includes any Claims or Interests held or Filed by any: (a) defendant in any litigation initiated by the Litigation Trustee or, in consultation with the Wind Down Trustee, Entity against whom the Litigation Trustee expects to initiate litigation; (b) any Broker Dealers; and (c) Holders of LBM L Bond Claims, in the event LBM withdraws from the settlement described in Article IV.I herein. Estimated recovery in Chapter 11 scenario is based on the Valuation Analysis. Chapter 7 recovery ranges have been adjusted to reflect the estimated impact of a chapter 7 Trustee monetizing the Estate Claims & Causes of Action.

Liquidation Costs

- F) Wind Down Costs: Represents estimated wind down cost in both the chapter 11 and chapter 7 scenarios for professional fees, support services for asset management, investor administration and reporting, insurance, document/data storage, IT systems and other miscellaneous costs.
- G) Litigation Recovery Costs: Represents estimated professional fees and expenses of the Litigation Trust to pursue estate claims and causes of action, reporting and other trust duties under the Second Amended Plan.

- H) Chapter 11 Wind Down Trustee Fees: Chapter 11 wind down trustee fees are estimated to be \$100,000 per month for the first six months and \$50,000 per month thereafter.
- I) Chapter 11 Litigation Trustee Fees: Chapter 11 litigation trustee fees are estimated to be \$50,000 per month.
- J) Chapter 7 Trustee Fees: This includes all fees paid to the chapter 7 trustee by the Debtors, consistent with the fee structure set forth in the Bankruptcy Code. Trustee fees are estimated at approximately 3% of the Total Estimated Recoveries excluding the Policy Portfolio Equity Interest plus, the gross recoveries of the Policy Portfolio.
- K) Chapter 7 Incremental Costs: Chapter 7 incremental costs includes estimated professional fees to address claims otherwise resolved in the Second Amended Plan.

Recovery Analysis

- L) Administrative Claims and Priority Tax Claims: Administrative Claims are for costs and expenses of the administration of the Debtors' Estates pursuant to sections 503(b), 507(a)(2), 507(b), or 1114(e)(2) of the Bankruptcy Code, including: (a) the actual and necessary costs and expenses of preserving the Debtors' Estates and operating the business of the Debtors incurred after the applicable Petition Date and through the Conversion Date; (b) Accrued Professional Compensation Claims; (c) the Independent Director Fee Claims; and (d) fees and charges assessed against the Debtors' Estates pursuant to Chapter 123 of the Judicial Code, including the fees of the U.S. Trustee payable pursuant to section 1930(a) of the Judicial Code. The Administrative Claims in the chapter 11 scenario assume an additional \$13 million for estimated transaction fees due to the Debtor's investment banker and CRO and the Bondholder Committee's investment banker. Priority Tax Claims are Claims of a Governmental Unit of the kind specified in section 507(a)(8) of the Bankruptcy Code.
- M) Vida DIP Claims: Claims for principal, interest, fees, costs, expenses, disbursements, and any other obligations of any kind under the Vida DIP Financing Facility, owing as of the Conversion Date. The Vida DIP Claims are accounted for as paid in determination of the Policy Portfolio Equity Interest. In the event the Vida DIP Claims are not paid in full, the shortfall is reflected as paid in the Claims Recovery Analysis.
- N) Chapford DIP Facility Claims: Claims for principal, interest, fees, costs, expenses, disbursements, and any and all other obligations of any kind under the Chapford DIP Facility, including any "DIP Obligations" (as defined in the Chapford Final DIP Order) owing as of the Conversion Date; provided that, for the avoidance of doubt, the Chapford DIP Facility Claims shall not include the purported Alternate Stalking Horse Fee (as defined in the Chapford Final DIP Order). The estimated Chapford DIP Facility Claims are currently assumed to be zero.
- O) DLP Secured Claims: Claims evidenced by, arising under, or in connection with the DLP IV Credit Agreement and DLP VI Credit Agreement or other agreements related thereto. The estimated DLP Secured Claims are currently assumed to be zero.

- P) Other Secured Claims: Secured Claim against any of the Debtors that is not: (a) a Chapford DIP Facility Claim; (b) a Vida DIP Claim; (c) a DLP Secured Claim; or (d) a Bond Claim. The estimated Other Secured Claims are currently assumed to be zero.
- Q) Other Priority Claims: Claims against any Debtor entitled to priority in right of payment under section 507 of the Bankruptcy Code, other than an Administrative Claim or a Priority Tax Claim.
- R) Indenture Fee and Expense Claim: Claims of the Indenture Trustee payable pursuant to Article IV.T of the Second Amended Plan, Article IV.L of the Second Amended Plan or the Indenture Documents, for its reasonable and documented fees and expenses and for indemnity, subrogation, and contribution, including, without limitation, attorneys' fees and expenses, arising under or in connection with the Indenture Documents, including in its capacity as collateral agent thereunder, whether before or after April 20, 2022 or before or after the Effective Date; *provided*, that, after the Effective Date, the Indenture Trustee shall not be able to assert any Claim against the Debtors or the Wind Down Debtors (except as otherwise provided in the Second Amended Plan). In both the chapter 7 and chapter 11 scenario the Indenture Fee and Expense Claim are assumed to be \$2.4 million and paid first from any distributions to Bondholder Claims, LBM L Bond Claims and LBM Subordinated Claims.
- S) Bondholder Claims: Claims for principal or interest evidenced by, arising under, or in connection with the Indenture (other than the Subordinated LBM L Bond Claims in chapter 11) as of April 20, 2022. The Bondholder Claims in the Liquidation Analysis excludes the LBM L Bond Claims that are accounted for separately. In the chapter 11 scenario, Total Proceeds in the Liquidation Analysis in excess of the Estimated Claim Amount reflect payment of accrued interest on Bondholder Claims at a rate of 9% per annum per the Second Amended Plan.
- T) LBM L Bond Claims (including LBM Subordinated Claims): Claims owed by the Debtors on Claims held by the following trusts for principal or interest evidenced by, arising under, or in connection with the Indenture as of April 20, 2022: The LT-1 Exchange Trust (c/o MHT Financial LLC), The LT-2 Exchange Trust, The LT-3 Exchange Trust, The LT-4 Exchange Trust, The LT-5 Exchange Trust, The LT-6 Exchange Trust, The LT-7 Exchange Trust, The LT-8 Exchange Trust, The LT-9 Exchange Trust, The LT-12 Exchange Trust, The LT-14 Exchange Trust, The LT-15 Exchange Trust, The LT-16 Exchange Trust, The LT-17 Exchange Trust, The LT-18 Exchange Trust, The LT-19 Exchange Trust, The LT-20 Exchange Trust, The LT-21A Custody Trust, The LT-22A Custody Trust, The LT-23A Custody Trust, The LT-24A Custody Trust, The LT-25A Custody Trust, and The LT-26A Custody Trust. The chapter 11 scenario assumes LBM has not timely withdrawn from the settlement described in Article IV.I of the Second Amended Plan, and receives the treatment provided in the Second Amended Plan for Allowed LBM L Bond Claims and LBM Subordinated Claims as of April 20, 2022. The chapter 7 scenario assumes there is no settlement and 100% of the LBM L Bond Claims (including the LBM Subordinated Claims) are paid pari-passu with all other Bondholder Claims. Recoveries in the Liquidation Analysis in excess of 100% are due to the payment of accrued interest on LBM

L Bond Claims in chapter 11 scenario at a rate of 9% per annum per the Second Amended Plan and in chapter 7 scenario at an assumed rate of 7.25% per annum.

- U) General Unsecured Claims: Claims that are not Secured and that are not: (a) an Administrative Claim; (b) a Chapford DIP Facility Claim; (c) a Vida DIP Claim; (d) a DLP Secured Claim; (e) a Priority Tax Claim; (f) an Other Secured Claim; (g) an Other Priority Claim; (h) a Bond Claim; (i) a DLP Entity General Unsecured Claim; or (j) an Intercompany Claim; *provided*, that, in the chapter 11, a Claim in the amount of \$2,750.00 or less that would otherwise be a General Unsecured Claim shall be treated as a GUC Convenience Claim for purposes of the Second Amended Plan. Recoveries in the Liquidation Analysis in excess of 100% are due to the payment of accrued interest on General Unsecured Claims in chapter 11 scenario at Federal Judgment Rate per the Second Amended Plan and in chapter 7 scenario at an assumed Federal Judgment Rate.
- V) GUC Convenience Claims: In the chapter 11 an Allowed Claim in an amount greater than \$0.01 but less than or equal to \$2,750.00, that would otherwise qualify as a General Unsecured Claim; *provided*, that any Holder of an Allowed General Unsecured Claim may elect to have such Claim reduced to \$2,750.00 and treated as an Allowed GUC Convenience Claim for purposes of the Second Amended Plan; *provided, further*, that, notwithstanding the foregoing, the total GUC Convenience Claims shall not exceed \$150,000 in the aggregate.
- W) DLP Entity General Unsecured Claims: Claim against any of the DLP Entities that is not Secured and that is not: (a) an Administrative Claim; (b) Chapford DIP Facility Claim; (c) Vida DIP Claim; (d) DLP Secured Claim; (e) Priority Tax Claim; (f) Other Secured Claim; (g) Other Priority Claim; (h) Bond Claim; or (i) Intercompany Claim. The estimated DLP Entity General Unsecured Claims are currently assumed to be zero.
- X) Intercompany Claims: Claims against a Debtor held by another Debtor.
- Y) Intercompany Interests: Interests in one Debtor held by another Debtor.
- Z) Series 1 Preferred Interests: Redeemable preferred shares issued by Debtor GWGH pursuant to that certain Registration Statement on Form S-1 filed pursuant to the Securities Act and declared effective by the SEC on October 30, 2015, with an initial stated value of \$1,000.00 per share.
- AA) Series 2 Preferred Interests: Redeemable preferred shares issued by Debtor GWGH pursuant to that certain Registration Statement on Form S-1 filed pursuant to the Securities Act and declared effective by the SEC on February 14, 2017, with an initial stated value of \$1,000.00 per share.
- BB) Common Stock in GWGH: Shares of common stock issued by Debtor GWGH.